



Liebert® CRV300

11-20kWDXversion;38-60kW CWversion

A/C Versions

Product Documentation
English , Cod. 265086, rev. 11.01.2018

Contents

Contents

1	Product Description
2	Application of Liebert CRV
3	Liebert CRV
4	Operation
5	Microprocessor Controls
6	Specifications
7	Heat Rejections
8	Installation drawings
9	Refrigerant, Hydraulic and Electrical Connections
10	Refrigeration & Hydraulic Circuits

The product conforms to European Union directives 2006/42/EC; 2014/30/EU; 2014/35/EU; 2014/68/EU.

Units are supplied complete with a test certificate and conformity declaration and control component list.



Liebert® CRV units are CE marked as they comply with the European directives concerning mechanical, electrical and electromagnetic safety.

1

Product Description

1.1 Product Description

The **Liebert® CRV** is an air cooled full-featured direct expansion and chilled water Thermal Management unit to be installed within a row of high density computing racks in a “hot-aisle-cold-aisle” configuration. Air heated by the room equipment enters the unit from the hot aisle; it is filtered, cooled, conditioned, and subsequently returned to the cold aisle. Supply air flow direction can be easily modified (via the optional air discharge baffles) to the left side or to the right side or to both directions so it may be placed between the racks or at the end of the row. It maximizes cooling effectiveness, reduces the occurrence of hot spots and improves the overall system efficiency.

The **Liebert® CRV** provides all the necessary functions provided by a standard precision air conditioner including cooling, heating, humidification, dehumidification, air filtration, condensate management, temperature control, alarm functions and data communications.

It is targeted for small and medium data centers and it is optimized to ensure maximum cooling capacity in a minimal footprint. The efficient components of the system are managed by the **Liebert iCOM® Control** system. The control monitors the environment in real-time by locating sensors on the inlet of the racks that the unit is cooling. This information allows the unit to optimize its operations in terms of performance and energy efficiency.

Service and maintenance are performed through the front and rear of the unit. All piping and electrical connections are made through the top or bottom of the unit.



CRV 300 CW



CRV 300 DX

2.1 First check

Before proceeding with Liebert® CRV application please make sure the unit selected is suitable for your site. Liebert® CRV is targeted for small and medium data centers and it is optimized for maximum cooling capacity in a minimal footprint. It is designed for high air inlet temperature (up to 40° C), therefore it is advised to accomplish Hot-Cold aisle configuration.

Liebert® CRV is able to modulate the cooling capacity in order to quick adjust to any changing heat load. Liebert® CRV is designed to provide proper control of the room temperature, humidity and air filtration. The specific design of Liebert® CRV is optimized in order to be extremely efficient without providing unnecessary latent cooling (dehumidification) not specifically required for cooling of IT electronic equipments, which enhance the overall cooling system efficiency.

2.1.1 Hot-Cold aisle configuration

A best practice is to use rows of equipment racks in an alternating arrangement of cold aisles and hot aisles.

In the cold aisle, the equipment racks are arranged face to face so the cold air discharged from the Liebert® CRV unit(s) is drawn into the front of the servers and exhausted out through the rear into the hot aisles. Hot aisles are literally hot because the objective of the alternating cold and hot aisle design is to separate the source of cooling air from hot air discharge which returns to the Liebert® CRV unit(s). Therefore, hot and cold aisle should be separated otherwise there would be a mix of hot and cold air and thereby lower the temperature of the air returning to the CRV units, which reduces their usable capacity.

Fig. 2a Example of high density installation with cold aisle and hot aisle alternation

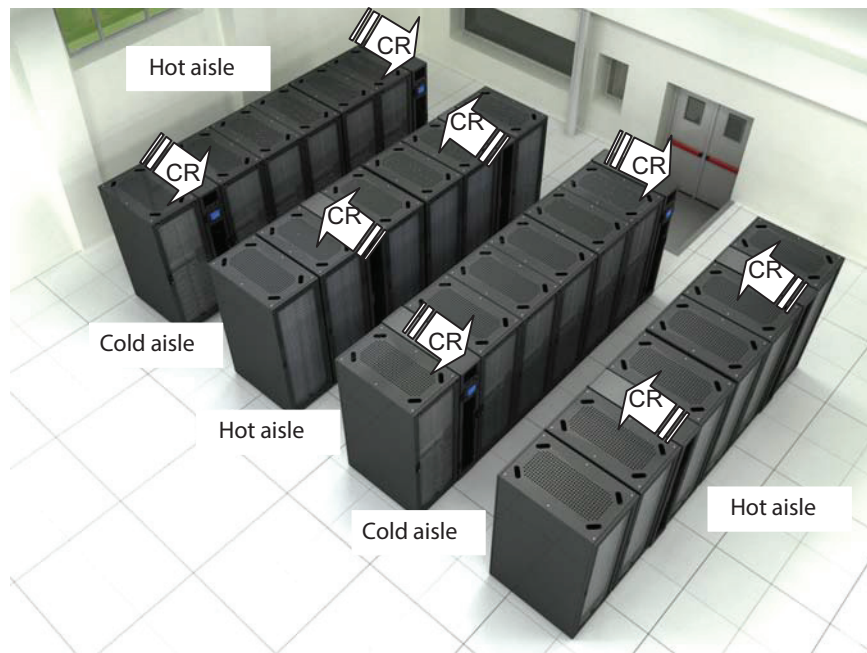

Application of Liebert® CRV

2.1.2 Combination with other Cooling systems

Liebert® CRV may be combined with other cooling systems such as underflow CRAC units (e.g. retrofit of current installation) until there is proper setting of both systems without influencing each other. Otherwise there is a risk of cycling or increased power consumption of both systems, in worst case causing malfunction of the units. For details contact Vertiv sales representative.

2.2 Selection of Liebert® CRV unit(s)

2.2.1 Number and size

When designing a cooling solution using the Liebert® CRV unit(s), the initial steps are similar to those required to cool a conventional critical space. The total heat load must be calculated, including sensible and latent cooling requirements. These should be increased by the reserve capacity needed for pull-down situations (e.g. after power failure) where the room temperature must be reduced and to cover unexpected increases in the heat load. Consider also redundant capacity, which is usually not in use in the normal operation, but takes duty if any of the running unit(s) fail.

So the different steps are:

- Check the heat load of IT equipment and apply safety margin if required.
- Define size and number of Liebert® CRV units in order to provide enough net sensible cooling capacity to cover the heat load. Typical air inlet temperatures to be considered for normal operation of the unit(s) are between 33° C and 37° C. Please refer also to point 2.2.3 Air Flow Requirements
- When N+X (typical N+1) redundancy is required, use more units so if any of the unit(s) fail, the remaining unit(s) will cover the heat load. Always consider the layout of the room when defining number of units, see chapter 2.4 Positioning-unit placement.

2.2.2 Air Flow Requirements

Liebert® CRV is optimized to provide precision cooling for IT equipment with temperature raise (delta T) of cooling air passing through the equipment around 15 to 20 degrees Celsius or higher. Such temperature raise is typical for Blade servers and standard pizza servers. For applications with very low delta T, around 10 degrees Celsius, typical for old fashion servers, it is necessary to de-rate cooling capacity of the Liebert® CRV due to higher air flow equipment.

In case of application with Cold Aisle Containment (Smart Aisle) it is necessary to carefully investigate the air flow through IT equipment and to define number of Liebert® CRV units in order to provide at least 5% more airflow, excluding redundant unit(s). Otherwise there may occur a situation with negative pressure in the Smart Aisle containment and hot air possibly leaking inside the containment.

2.3 Operating limits

The units are designed to operate within working ranges.

These limits are referred to new machines or to those that have been correctly installed and serviced. The warranty clauses are no longer valid for any possible damage or malfunction that may occur during or due to operation outside the application values.

2.3.1 For all units

		From:	To
Room air conditions	Temperature	27°C	40°C
	Humidity ratio	5.5 g/kg	11 g/kg
	Relative humidity	20 %	60 %
Storage conditions	Temperature	- 20°C	50°C
	Relative humidity	Max. 90% RH, preventing surface condensation.	
Power supply tolerances		V ± 10 %	
		Hz ± 2	

Application of Liebert® CRV

2.3.2 For A units

Outdoor temperature: lower limit -10°C

To install an air conditioner in places in which external temperature reaches very low values sometime in the year requires some means of control to maintain adequate condensing pressures to ensure proper liquid system operation.

With low temperatures the refrigerant condensates in pipeline and the liquid tends to fulfill the condenser.

It's mandatory to install the following components:

1. NON RETURN VALVE (liquid line)

Install a non- return valve in the liquid line directly out of the condenser. It doesn't allow the liquid to come back to the condenser (that means efficiency loss and dangerous stress for the compressor).

2. VARIEX FAN SPEED CONTROL

Use Variex fan speed control to regulate the condensing pressure and have a continuous and better subcooling control.

It's suggested to have:

3. HORIZONTAL CONDENSER POSITION

The condenser horizontal disposition (vertical flow) is necessary to reduce subcooling variations due to direct wind exposure. (very important to have a good subcooling control).

For all exceptions contact the Liebert® Sales Representative.

Outdoor temperature: higher limit

This limit is determined by coupled condenser model. In any case the max external temperature is 48°C Exceeding of this limit (or a lack of maintenance), will caused a compressor stop by HP safety thermostat. Reset to normal operation can only be carried out manually.

Remote Condenser

To ensure correct operation, best performance, and longest life the units must be connected to remote condensers approved by Vertiv .

The warranty clauses are no longer valid if unit is connected to a not approved remote condenser.

Relative position room unit vs. 50 Hz remote condenser	
From unit to condenser max distance equivalent length, m ⁽¹⁾	100
From unit to condenser max geodetic height, m ⁽¹⁾⁽²⁾	Max above 30 Max below 8
Requirements	
Pipe diameter ⁽¹⁾	see the User Manual
Oil traps on vertical line of gas refrigerant, m	every 6

For length higher than 30m condenser oversized +15%.

(1) For more details see User Manual

(2) Positive difference in height: condenser above conditioner. Negative difference in height: condenser below conditioner

2.3.3 For C units

Max. water pressure 16 bar Max. differential pressure through the closed valve: Dp_{cv} Max. differential pressure across the valve for modulating service: Dp_{ms}		
Models	Dp_{cv} (kPa)	Dp_{ms} (kPa)
CR032RC	300	300
CR038RC	300	300
CR060RC	175	175

2.4 Positioning - Units placement

This chapter provides some ideas of typical installation of the Liebert® CRV unit(s), shows several examples of the server room layouts and applications using Liebert® CRV units.

In order to eliminate the transmission of vibrations, avoid any contacts between Liebert® CRV unit and the racks of the server room. If coverage (e.g. “Smart Aisle™”) is installed, avoid its contemporary contact with both, racks and CRV.

For best performances of Liebert® CRV is important to:

- reduce at minimum recirculation from hot aisle around the ends and/or over the top of the racks, prevent gaps between the racks
- reduce at minimum recirculation from hot aisle through server racks by using blanking panels
- ensure cold air is being distributed across the front of all neighboring equipment racks by properly placed Liebert® CRV unit(s)
- distribute load within the rack - it is generally advised to distribute the load as much possible uniformly across the rack height.

For more details refer to following details or contact Vertiv Sales Representative.

2.4.1 Single Row Placement

The Liebert® CRV can be placed either at the end of a row or in between server racks. Locating a Liebert® CRV at the end of a row helps to isolate the end of the cold aisle from the surrounding space; protecting it from hot air wrapping around the sides of the aisle. The 2T rack temperature sensors sample supply and return air temperatures.

When deploying multiple Liebert® CRV, it is recommended that units be installed at the end of rows with their baffles set to direct cold supply air towards the server equipment (Fig. 2b). Depending on row length, heat density and airflow requirements, additional cooling units can be installed throughout the row with their baffles set to direct supply air left and right.

Fig. 2b Liebert® CRV – Single Row Placement

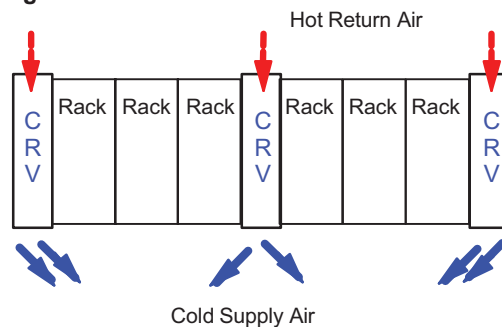

2.4.2 Two Rows Placement

Cooling becomes more effective when there is a barrier or a second row of racks in front of the Liebert® CRV unit. Also in this case it is recommended to install one Liebert® CRV unit at each end of the 2 rows, with their baffles directed towards the IT equipment. Depending on the row length, heat density and airflow requirements, additional cooling units can be installed throughout the row with their baffles set to direct supply air left and right (Fig. 2c).

Application of Liebert® CRV

Fig. 2c Liebert® CRV – Two Rows Placement

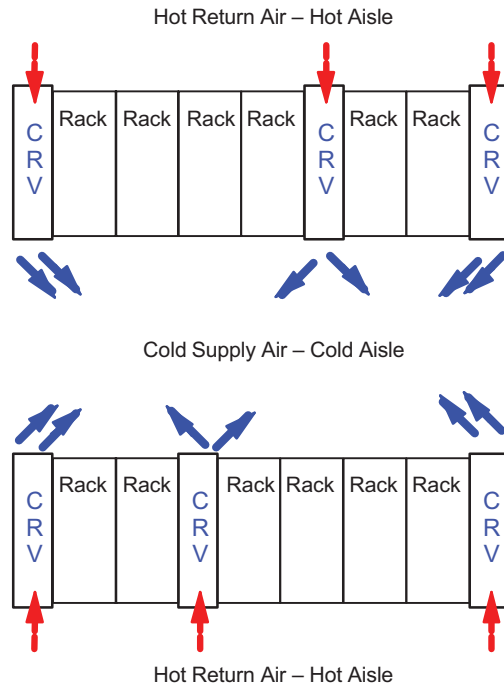

Cooling unit location within a row becomes less critical when deployed in SmartAisle™ containment, but it is recommended that the Liebert® CRV be evenly spaced in each row. Using room barriers, such as walls shown in Fig. 2.d and Fig. 2.e, it can be very effective in simulating aisle containment. When the depths of a Liebert® CRV and neighboring server rack are not the same, it is important to align the front edges of the Liebert® CRV with the front edges of the neighboring server racks to allow for proper air distribution.

Fig. 2d Simulated aisle containment using room barriers – single row

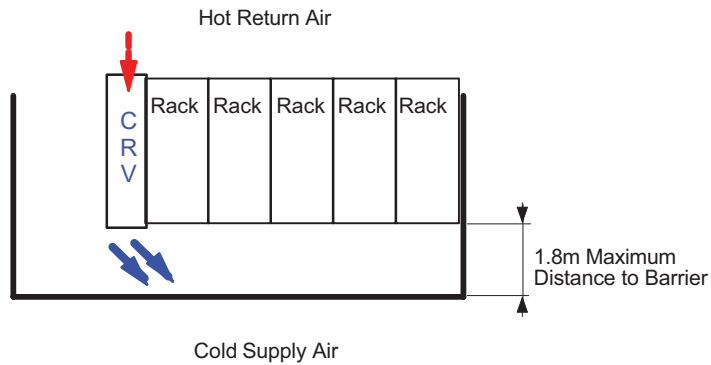

Application of Liebert® CRV

Fig. 2e Simulated aisle containment using room barriers - multiple rows

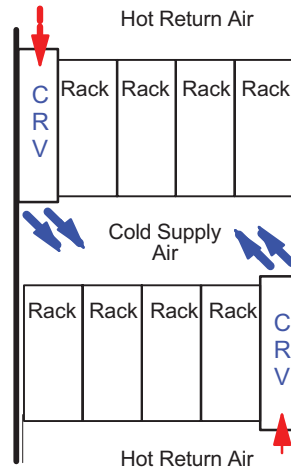

2.4.3 Liebert® CRV Applied in SmartAisle™ Cold Aisle Containment

Using the Liebert® CRV with the SmartAisle™ is always recommended to ensure top efficiency, but not required. It is an excellent solution when attempting to cool widely varying heat loads, (ie. exceeding 10kW per rack), and when seeking the highest efficiency systems. Fully containing the cold aisle will allow to automatically balance the Liebert® CRV cooling capacity and airflow to the server rack's requirements in real-time.

The 2T rack temperature sensors installed in the sensor boxes of the containment can be used to control the fan speed of the unit in the SmartAisle™ mode.

Version "Without Air Discharge Baffles" can be used in SmartAisle™ applications.

Fig. 2f Liebert® CRV Placement in SmartAisle™ Cold Aisle Containment Application

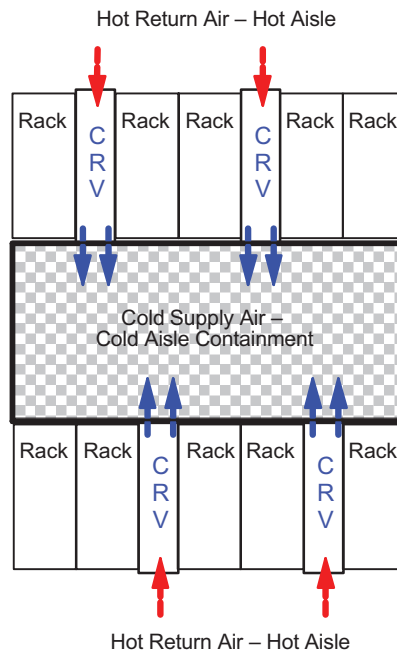

2.5 Temperature sensors

The sensor may be placed where desired or left coiled inside the unit. It is recommended that the sensor be routed to the front of the heat load for the most accurate temperature reading. In InRow configuration, the temperature sensor monitors the temperature of the air entering the rack equipment. The reading is used to control the operation of the unit, so the sensor must be placed as directed below or the equipment will not operate properly.

Insert the rack temperature sensor connector in the temperature sensor port at the iCOM interface.

Secure the temperature sensor in front of the warmest heat source in the enclosure. Do not secure in front of a blanking panel. The sensors must be installed where lack of sufficient cooling air is most likely.

The optimum position of the rack temperature sensors will vary from installation to installation.

Servers most likely to have insufficient or inadequately cooled cooling air due to the recirculation of hot air from the hot aisle include:

- Servers positioned at the top of a rack.
- Servers positioned at any height in the last rack at an open end of a row.
- Servers positioned behind flow-impairing obstacles such as building elements.
- Servers positioned in a bank of high-density racks.
- Servers positioned next to racks with air removal units.
- Servers positioned very far from the equipment.
- Servers positioned very close to the equipment.

3.1 Standard features

Air cooled models

DX COOLING COIL It is constructed of copper tubes and hydrophilic coated aluminium fins. The hydrophilic coating provides superior water carryover resistance. A stainless steel condensate drain pans are provided.

REFRIGERATION SYSTEM Single refrigeration circuit includes a liquid line filter drier, a refrigerant sight glass with moisture indicator, an electronic expansion valve, and a liquid line solenoid valve.

COMPRESSOR The compressor is an R410A DC inverter scroll type with variable capacity operation from 30-100%. The limit of capacity variation is depending by the installation type and the room conditions. The compressor has a suction gas cooled motor, vibration isolators, internal thermal overloads, manual reset high pressure switch, low pressure and high pressure transducer, crankcase heater, internal centrifugal oil pump, and an operating speed of 3000RPM @ 50Hz.

ELECTRONIC EXPANSION VALVE DEVICE (EXV) The valve is designed for modulating control of refrigerant circuits with high speed and high precision. It is suitable for use as expansion device in refrigerant circuits with DC Inverter Scroll compressor, with organic safety refrigerants (i.e. R410A).

For variable capacity systems, an EXV provides superior performance as compared to a traditional thermostatic expansion valve (TXV), due to:

- Precise flow control
- Positioning time

Electronic expansion valve ensure a better control on superheating at the outlet of the evaporator, ensuring at same that compressor will never be filled by liquid. Moreover the EXV valve let the condensing temperature goes down to 33°C.

FAN The unit is equipped with five (CR021) or three (CR011) direct driven radial fans with backward curved blades and Electronically Commutated DC motors; commonly referred to as EC plug fans.

The fan speed is variable and automatically regulated by the iCOM control through all modes of operation. Each fan has a dedicated motor which provides a level of redundancy. The fans pull air through the coil and are located on the front side of the unit.

iCOM CONTROL SYSTEM The Liebert CRV is controlled by the iCOM Control System. The standard user interface is the Large Graphical Display (320x240 pixels, backlit) which presents system information and allows all parameters to be viewed and adjusted. It features push-button navigation, operational status LEDs, and a 3-level password protection system. iCOM without display is available as option. Unit without display can be controlled through a display of another unit in the same group or through a service display. Unit-to-Unit communication with other Liebert CRVs and two IntelliSlot communication card housings are included as standard.

2T RACK TEMPERATURE SENSORS Consist of a vented case with two temperature probes. Up to 10 2T housings (20 temperature probes) can be connected to a Liebert CRV. One 2T housing and both sensor probes are to be attached to a rack the cooling unit is conditioning. The sensors provide real-time, direct feedback to the cooling unit to optimize the amount of cooling and airflow required; increasing energy efficiency and ensuring proper rack inlet air temperatures. The sensor data can also be reported to remote BMS and monitoring systems. The sensor network consists of one CAN wire leaving the cooling unit and connecting to a 2T sensor. Each remaining 2T sensor is connected to the previous sensor; often referred to as a daisy-chain configuration.

REMOTE SHUTDOWN TERMINAL Provides the customer with a location to remotely shut down the unit.

COMMON ALARM CONTACT Provides the customer with a set of normally open (n/o) contacts for remote indication of unit alarms.

CABINET The exterior steel panels are custom powder coated to protect against corrosion. The double wall constructed side panels separate the ½", 2.0 lb/ft³ insulation from the airstream. The unit is mounted on casters for quick installation and provided with levelling feet. The perforated inlet and outlet panels have 81% open area.

SERVICE ACCESS All service and maintenance is performed through the front and rear of the unit; including any component removal. No side access is required. All electrical and piping connections are made through the top and/or bottom of the unit.

FILTER The unit is equipped with two air filters rated G2 following EN779, located within the cabinet, and accessible from the rear of the unit. Air filter F5 are available as option. A filter clog alarm is included as an option.

LOCKING DISCONNECT SWITCH A molded case circuit interrupter disrupts the flow of power to the unit. The electric panel high voltage compartment can only be accessed with the switch in the 'off' position. It is located behind the back door for a quick access.

5 PORT ETHERNET SWITCH The unit is equipped with 5 port Ethernet Switch for connection of the units into LAN to enable team work.

Chilled water models

CW COOLING COIL It is constructed of copper tubes and hydrophilic coated aluminum fins. The hydrophilic coating provides superior water carryover resistance. Two stainless steel condensate drain pans are provided.

CHILLED WATER SYSTEM The water circuit includes a 3-way modulating valve. The Liebert iCOM control positions the valve in response to room conditions. Cooling capacity will be controlled by bypassing chilled water around the coil.

FAN The unit is equipped with six plug fans: direct driven centrifugal fans with backward curved blades and Electronically Commutated DC motors; commonly referred to as EC plug fans. The fan speed is variable and automatically regulated by the iCOM control through all modes of operation. Each fan has a dedicated motor and speed controller which provides a level of redundancy. The fans pull air through the coil and are located on the front side of the unit.

3-WAY MODULATING VALVE A 3-way modulating valve controls the chilled water flow passing through the cooling coil. The iCOM control manages the valve actuator movement in order to provide the desired amount of cooling for various entering water flow rates and temperatures. Cooling capacity is regulated by bypassing chilled water around the coil. The maximum differential pressure across the closed valve is 175 kPa. Maximum system pressure is 1586 kPa.

iCOM CONTROL SYSTEM The Liebert CRV is controlled by the iCOM Control System. The standard user interface is the Large Graphical Display (320x240 pixels, backlit) which presents system information and allows all parameters to be viewed and adjusted. It features push-button navigation, operational status LEDs, and a 3-level password protection system. iCOM without display is available as option. Unit-to-Unit communication with other Liebert CRVs and two Intelli Slot communication card housings are included as standard.

2T RACK TEMPERATURE SENSORS Consist of a vented case with two temperature probes. Up to 10 2T housings (20 temperature probes) can be connected to a Liebert CRV. One 2T housing and both sensor probes are to be attached to a rack the cooling unit is conditioning. The sensors provide real-time, direct feedback to the cooling unit to optimize the amount of cooling and airflow required; increasing energy efficiency and ensuring proper rack inlet air temperatures. The sensor data can also be reported to remote BMS and monitoring systems. The sensor network consists of one CAN wire leaving the cooling unit and connecting to a 2T sensor. Each remaining 2T sensor is connected to the previous sensor; often referred to as a daisy-chain configuration.

REMOTE SHUTDOWN TERMINAL Provides the customer with a location to remotely shut down the unit.

COMMON ALARM CONTACT Provides the customer with a set of normally open (n/o) contacts for remote indication of unit alarms.

CABINET The exterior steel panels are custom powder coated to protect against corrosion. The double wall constructed side panels separate the 1/2", 2.0 lb/ft³ insulation from the air stream. The unit is mounted on casters for quick installation and provided with leveling feet. The perforated inlet and outlet panels have 81% open area.

SERVICE ACCESS All service and maintenance is performed through the front and rear of the unit. No side access is required. All electrical and piping connections are made through the top and/or bottom of the unit.

FILTER The unit is equipped with two air filters rated G2 following EN779, located within the cabinet, and accessible from the rear of the unit. Air filter F5 are available as option. A filter clog alarm is included as an option.

LOCKING DISCONNECT SWITCH A molded case circuit interrupter disrupts the flow of power to the unit. The electric panel high voltage compartment can only be accessed with the switch in the 'off' position. Conveniently located behind the back door for a quick access.

5 PORT ETHERNET SWITCH The unit is equipped with 5 port Ethernet Switch for connection of the units into LAN to enable team work.

3.2 Optional features

Air cooled models

SUPPLY AIR BAFFLE A field adjustable, modular supply air baffle is located in the discharge air stream. It can be quickly and easily reconfigured to redirect airflow. The angles of the vanes have been optimized to effectively distribute air to heat generating equipment in a wide variety of applications.

CONDENSATE PUMP It has a capacity of 50 l/h at 3.7 m head. A float signal is available for a remote alarm. Please notice that at 4 m head the flowrate is 0.

HUMIDIFIER A steam generating canister humidifier is factory-installed in the cooling unit and is operated by the iCOM control system. It is complete with disposable cylinder, all supply and drain valves, steam distributor and electronic controls. The need to change the canister is indicated on the iCOM display, if available. The humidifier is designed to operate with water conductivity from 125-500 (50Hz) microS/cm. System automatically fills and drains as well as maintains the required water level based on conductivity. An air-gap within the humidifier assembly shall prevent backflow of the humidifier supply water. The humidifier is removable from the rear of the cabinet.

ELECTRIC REHEAT The electric reheat coils are low watt density, 304 stainless steel fin-tubular construction, protected by thermal safety switches and controlled in one stage.

INTELLISLOT UNITY CARD (IS-UNITY-DP) Provides monitoring via SNMP, Modbus (RS485/IP), BACnet (RS485/IP) and HTTP (Web) protocols

INTELLISLOT SITESCAN CARD (IS-485EXI) Provides monitoring via Liebert SiteScan Web 4.0 Protocol

FILTER The optional F5 class (following EN779) filters are two deep pleated 60 mm, located within the cabinet and accessible from the rear of the unit. A filter clog alarm is included as an option.

ONE (1) EXTRA COMMON ALARM CONTACT Provides the customer with a total of two sets of normally open (n/o) contacts for remote indication of unit alarms.

LIQUISTAT SENSOR Is a solid state water sensor that has no moving parts and is hermetically sealed to keep out dust and dirt. When the sensor detects the presence of moisture the alarm system is activated.

DUAL POWER SUPPLY with an internal automatic transfer switch is available as an option. With this option the unit can be connected to 2 separate power supplies where each power supply is able to completely feed the unit. In case of failure of the main supply the unit automatically switches to the second power supply. This allows to have a complete power supply redundancy.

Chilled water models

CONDENSATE PUMP It has a capacity of 50 l/h at 3.7 m head. A float signal is available for a remote alarm. Please notice that at 4 m head the flowrate is 0.

HUMIDIFIER A steam generating canister humidifier is factory-installed in the cooling unit and is operated by the iCOM control system. It is complete with disposable cylinder, all supply and drain valves, steam distributor and electronic controls. The need to change the canister is indicated on the iCOM display, if available. The humidifier is designed to operate with water conductivity from 125-500 (50Hz) micro S/cm. System automatically fills and drains as well as maintains the required water level based on conductivity. An air-gap within the humidifier assembly shall prevent backflow of the humidifier supply water. The humidifier is removable from the rear of the cabinet.

ELECTRIC REHEAT The electric reheat coils are low watt density, 304 stainless steel fin---tubular construction, protected by thermal safety switches and controlled in one stage.

2-WAY MODULATING VALVE A 2-way modulating valve controls the chilled water flow passing through the cooling coil. The iCOM control manages the valve actuator movement in order to provide the desired amount of cooling for various entering water flow rates and temperatures. Cooling capacity is regulated by closing-off the chilled water flow. The maximum differential pressure across the closed valve is 175 kPa. Maximum system pressure is 1586 kPa.

SUPPLY AIR BAFFLE A field adjustable, modular supply air baffle is located in the discharge air stream. It can be quickly and easily reconfigured to redirect airflow. The angles of the vanes have been optimized to effectively distribute air to heat generating equipment in a wide variety of applications.

INTELLISLOT UNITY CARD (IS-UNITY-DP) Provides monitoring via SNMP, Modbus (RS485/IP), BACnet (RS485/IP) and HTTP (Web) protocols.

INTELLISLOT SITESCAN CARD (IS-485EXI) Provides monitoring via Liebert SiteScan Web 4.0 Protocol.

FILTER The optional F5 class (following EN779) filters are two deep pleated 60 mm, located within the cabinet and accessible from the rear of the unit. A filter clog alarm is included as an option.

ONE (1) EXTRA COMMON ALARM CONTACT Provides the customer with a total of two sets of normally open (n/o) contacts for remote indication of unit alarms.

LIQUISTAT SENSOR Is a solid state water sensor that has no moving parts and is hermetically sealed to keep out dust and dirt. When the sensor detects the presence of moisture the alarm system is activated.

DUAL POWER SUPPLY with an internal automatic transfer switch is available as an option. With this option the unit can be connected to 2 separate power supplies where each power supply is able to completely feed the unit. In case of failure of the main supply the unit automatically switches to the second power supply. This allows to have a complete power supply redundancy.

4

Operation

Unit operation is completely automatic. The below sequence explains how the unit operates:

- The air, sucked in by the continuously operating fans, enters the unit.
- The air is immediately filtered.
- The TEMPERATURE sensor or HUMITEMP (temperature + rel. humidity) sensor (depends on unit configuration), verifies the state of the inlet air, and relays this information to the control system.
- The air is treated and then blown out of the unit.
- The control system compares the relayed information to the set point and proportional band values programmed into its memory: it then commands the air conditioner to treat the air as follows (see also Control manual).

4.1 Cooling

- Direct expansion mode (DX)
The compressor is started and the cold refrigerant flows through the evaporator, thus cooling the air passing over it. For compressor operation see Control manual.
- Chilled water mode (CW)
The three ways valve is opened and the chilled water flows through the coil, thus cooling the air passing over it.
For valve operation see Control manual.

4.2 Heating

- Electrical heating (optional): the heating elements heat the air passing over them. There is one heating steps activate in case of dehumidification if supply air temperature is too low (for heating logic see Control manual)

4.3 Dehumidification

- DX mode
The compressors starts and either the air flow or the evaporator surface is reduced (increasing modulation capacity of compressor), thereby causing dehumidification (refer also to Control manual).
- N.B.: If, during dehumidification, the ambient temperature drops below a specified level, dehumidification will be stopped if necessary (see LOW LIMIT intervention in Control manual).
In dehumidification mode, the air after passing over the coil it's reheated (if needed) by electrical heater to re-stabilize the initial temperature

4.4 Humidification - optional

- The humidifier creates steam, which is distributed into the air via the steam distribution pipe

5.1 iCOM Control

Liebert CRV models are controlled by iCOM Medium Board (Fig. 5.a).

The control board is housed in the electrical panel and it is connected to the remote display, to be installed in the container/room (connection cable is included).

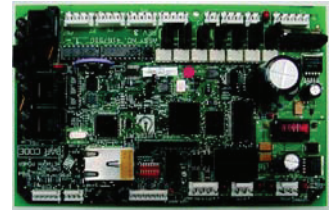

- The standard user interface is a graphical display (128 x 64 pixels, backlit) showing parameter values and the relevant symbols/codes in a tree menu. It features navigation push-buttons and status leds. Self-explanatory icons are used for the menu-layout of the display.
- Status Report of the latest 400 event-messages of the unit.
- Graphic Data Records for temperature and humidity
- Both high and low priority alarms activate a visual indicator and buzzer.
- Input for remote on-off and volt-free contacts for simple remote monitoring of low and high priority alarms: high/low temperature, high/low refrigerant pressure, fan/control failure, compressor/control failure and others are available.
- LAN management: functions provided as standard include stand-by (in case of failure of the unit in operation, the second one starts automatically), and automatic rotation.
- All settings are protected through a 3-Level password system (*).
- Automatic restart is provided after a power failure.



Tab. 5a - Technical Data

Technical Data	iCOM Medium
E2prom	4Mbit + 512kbit
Flash memory	32Mbit
RAM memory space	128Mbit
Microcontroller	Coldfire 32Mbit
Analogue Input	3 x 0-10V,0-5V,4..20mA (selectable) + 2 PTC/NTC + 3 NTC
Digital Input	9 x opto-coupled
Analogue Output	2 x 0-10V
Digital Output	7 triacs output and 2 relay output
Time and date function buffered by LI-battery	
Hirobus Lan connectors	2 RJ45 sockets (for unit in LAN, remote display)
Ethernet network connectors	1 RJ45 socket
CAN bus connectors	2 RJ12 sockets
Hironet connectors	1 RJ9 socket for RS485 (direct connection to proprietary supervision)

Microprocessor Controls

5.2 CDL Graphic Display (option)

- Large graphic display (320 x 240 pixels)
- Self-explanatory icons are used for the menu-layout of the CDL Display.
- Status Report of the latest 400 event-messages of the unit/system.
- Graphic Data Records for temperature and humidity, selectable time-frames from 8 minutes to 2 weeks.
- Semi or Full Manual Mode software management including all safety devices.
- 4-Level Password system to protect all settings.
- Ergonomic design for use also as portable device (start-up and “flying connections” by service personnel).



Technical Data CDL Graphic Display

- Microcontroller: Coldfire 32Mbit
- Ethernet network connectors 2 RJ45 sockets (for unit in LAN, remote display)
- CAN bus connectors 2 RJ12 sockets
- Power supply: via CAN bus or external 12Vdc supply

5.3 iCOM without Display (option)

- Internal 3 digit display
- 3 color LED light status indicator on front door
- Switch for local ON/OFF on front door

CRV units with internal display can be controlled by a 3 digit internal display located behind the front door or through CDL of another CRV unit in the same network group. The 3 color LED light indicator provides information about the unit status (Active, Stand by, Alarm).

The hole for the CDL is covered by a blanking panel which enables easy field upgrade of this unit with CDL if needed in the future. CDL upgrade kit is available as an accessory.



6

Specifications

1.1 Performances - air cooled

Tab. 6a - Air cooled

	Cond. Temp. 45°C	
	CR011RA	CR021RA
40°C DB - 20% RH		
Net Total kW	11.8	20.9
Net Sensible kW	11.8	20.9
Unit Power Input kW	2.99	5.16
Heat rejection kW	14.79	26.06
Supply Air Temperature °C	26.3	23.8
37°C DB - 24% RH		
Net Total kW	11.6	20.6
Net Sensible kW	11.6	20.6
Unit Power Input kW	3.17	5.49
Heat rejection kW	14.77	26.09
Supply Air Temperature °C	23.7	21.2
35°C DB - 26% RH		
Net Total kW	11.4	20.3
Net Sensible kW	11.4	20.3
Unit Power Input kW	3.30	5.68
Heat rejection kW	14.70	25.98
Supply Air Temperature °C	22	19.5
32°C DB - 29% RH		
Net Total kW	11.2	19.7
Net Sensible kW	11.2	19.7
Unit Power Input kW	3.57	5.94
Heat rejection kW	14.77	25.64
Supply Air Temperature °C	19.4	17.1
30°C DB - 34% RH		
Net Total kW	11	19.4
Net Sensible kW	11	19.4
Unit Power Input kW	3.58	6.14
Heat rejection kW	14.58	25.54
Supply Air Temperature °C	17.6	15.5
28°C DB - 38% RH		
Net Total kW	10.9	19.3
Net Sensible kW	10.9	19.3
Unit Power Input kW	3.63	6.27
Heat rejection kW	14.53	25.57
Supply Air Temperature °C	15.9	13.3

Specifications

	Cond. Temp. 45°C	
	CR011RA	CR021RA
28°C DB - 45% RH		
Net Total kW	11.3	19.7
Net Sensible kW	10.7	17.9
Unit Power Input kW	3.57	6.01
Heat rejection kW	14.87	25.71
Supply Air Temperature °C	16.1	14.8
25°C DB - 45% RH		
Net Total kW	10.7	18.9
Net Sensible kW	10.6	17.7
Unit Power Input kW	3.77	6.40
Heat rejection kW	14.37	25.30
Supply Air Temperature °C	13.3	12
25°C DB - 40% RH		
Net Total kW	10.4	18.6
Net Sensible kW	10.4	18.6
Unit Power Input kW	3.78	6.53
Heat rejection kW	14.18	25.13
Supply Air Temperature °C	13.5	11.2
22°C DB - 55% RH		
Net Total kW	10.4	18.6
Net Sensible kW	8.9	15.1
Unit Power Input kW	3.78	6.53
Heat rejection kW	14.18	25.13
Supply Air Temperature °C	12.4	11.1
22°C DB - 50% RH		
Net Total kW	10.1	18.3
Net Sensible kW	9.4	16.1
Unit Power Input kW	3.79	6.60
Heat rejection kW	13.89	24.9
Supply Air Temperature °C	11.8	10.3

Specifications

Tab. 6b - Air cooled

50Hz	CR032RC			CR038RC			CR060RC		
	7°C EWT, 5°C Water Rise	10°C EWT, 5°C Water Rise	13°C EWT, 5°C Water Rise	7°C EWT, 5°C Water Rise	10°C EWT, 5°C Water Rise	13°C EWT, 5°C Water Rise	7°C EWT, 5°C Water Rise	10°C EWT, 5°C Water Rise	13°C EWT, 5°C Water Rise
40°C DB - 20% RH									
Total kW	34.5	31.1	27.8	45.00	40.60	36.20	63.80	57.60	51.30
Sensible kW	34.2	31.1	27.8	45.00	40.60	36.20	63.80	57.60	51.30
Unit Power Input kW	0.92	0.92	0.92	1.70	1.70	1.70	3.02	3.02	3.02
Flow Rate, l/s	1.64	1.49	1.33	2.14	1.84	1.73	3.04	2.75	2.45
Pressure Drop, kPa	113	93	74	184.00	151.00	121.00	203.00	166.00	133.00
Supply Air Temp. °C	13.8	16.2	18.9	15.40	17.90	20.40	15.20	17.70	20.30
37°C DB - 24% RH									
Total kW	31.9	27.8	24.4	40.60	36.20	31.70	57.70	51.40	45.10
Sensible kW	30.7	27.8	24.4	40.60	36.20	31.70	57.70	51.40	45.10
Unit Power Input kW	0.92	0.92	0.92	1.70	1.70	1.70	3.02	3.02	3.02
Flow Rate, l/s	1.52	1.33	1.17	1.94	1.73	1.52	2.75	2.46	2.16
Pressure Drop, kPa	98	75	59	153.00	122.00	95.00	169.00	135.00	105.00
Supply Air Temp. °C	13.8	16.1	18.7	15.10	17.60	20.10	14.90	17.50	20.00
35°C DB - 26% RH									
Total kW	29	25.6	22.1	37.70	33.20	28.70	53.50	47.20	40.90
Sensible kW	28.6	25.6	22.1	37.70	33.20	28.70	53.50	47.20	40.90
Unit Power Input kW	0.92	0.92	0.92	1.70	1.70	1.70	3.02	3.02	3.02
Flow Rate, l/s	1.38	1.22	1.09	1.80	1.59	1.38	2.55	2.26	1.95
Pressure Drop, kPa	82	65	49	133.00	105.00	79.00	93.00	116.00	88.00
Supply Air Temp. °C	13.6	15.9	18.6	14.90	17.40	19.90	14.70	17.30	19.90
32°C DB - 29% RH									
Total kW	25.6	22.1	18.6	33.20	28.70	24.20	47.20	40.80	34.40
Sensible kW	25.6	22.1	18.6	33.20	28.70	24.20	47.20	40.80	34.40
Unit Power Input kW	0.92	0.92	0.92	1.70	1.70	1.70	3.02	3.02	3.02
Flow Rate, l/s	1.22	1.06	0.89	1.59	1.37	1.16	2.25	1.95	1.64
Pressure Drop, kPa	65	50	36	106.00	80.00	81.00	117.00	89.00	64.00
Supply Air Temp. °C	13.1	15.8	18.4	14.60	17.10	19.60	14.50	17.00	19.60
30°C DB - 34% RH									
Total kW	23.2	19.7	16.2	30.20	25.70	21.10	43.00	36.50	30.00
Sensible kW	23.2	19.7	16.2	30.20	25.70	21.10	43.00	36.50	30.00
Unit Power Input kW	0.92	0.92	0.92	1.70	1.70	1.70	3.02	3.02	3.02
Flow Rate, l/s	1.11	0.94	0.78	1.44	1.23	1.01	2.05	1.74	1.44
Pressure Drop, kPa	55	40	28	89.00	65.00	45.00	99.00	73.00	50.00
Supply Air Temp. °C	13	15.6	18.3	14.30	16.90	19.40	14.30	16.90	19.40
28°C DB - 38% RH									
Total kW	20.9	17.4	13.7	27.10	22.50	17.80	38.60	32.10	25.50
Sensible kW	20.4	17.4	13.7	27.10	22.50	17.80	38.60	32.10	25.50
Unit Power Input kW	0.92	0.92	0.92	1.70	1.70	1.70	3.02	3.02	3.02
Flow Rate, l/s	1	0.83	0.66	1.29	1.08	0.85	1.84	1.54	1.22
Pressure Drop, kPa	45	32	20	73.00	51.00	33.00	82.00	58.00	37.00
Supply Air Temp. °C	13.3	15.6	18.3	14.10	16.70	17.30	14.10	16.70	19.30

Specifications

50Hz	CR032RC			CR038RC			CR060RC		
	7°C EWT, 5°C Water Rise	10°C EWT, 5°C Water Rise	13°C EWT, 5°C Water Rise	7°C EWT, 5°C Water Rise	10°C EWT, 5°C Water Rise	13°C EWT, 5°C Water Rise	7°C EWT, 5°C Water Rise	10°C EWT, 5°C Water Rise	13°C EWT, 5°C Water Rise
28°C DB - 45% RH									
Total kW	25.4	17.4	13.8	32.00	22.60	17.90	45.10	32.10	25.50
Sensible kW	20.1	16.7	13.8	26.40	22.60	17.90	36.90	32.10	25.50
Unit Power Input kW	0.92	0.92	0.92	1.74	1.70	1.70	3.14	3.02	3.02
Flow Rate, l/s	1.21	0.83	0.66	1.53	1.08	0.86	2.15	1.54	1.22
Pressure Drop, kPa	65	32	21	99.00	51.00	33.00	108.00	58.00	37.00
Supply Air Temp. °C	13.5	16.1	18.3	14.60	16.70	17.30	14.90	16.70	19.30
25°C DB - 45% RH									
Total kW	17.3	13.6	9.6	22.40	17.70	12.70	32.00	25.30	18.30
Sensible kW	17	13.6	9.6	22.40	17.70	12.70	32.00	25.30	18.30
Unit Power Input kW	0.92	0.92	0.92	1.70	1.70	1.70	3.02	3.02	3.02
Flow Rate, l/s	0.82	0.65	0.46	1.07	0.84	0.61	1.53	1.21	0.88
Pressure Drop, kPa	32	20	11	51.00	33.00	18.00	58.00	37.00	21.00
Supply Air Temp. °C	12.9	15.5	18.5	13.80	16.40	19.10	13.90	16.50	19.20
25°C DB - 40% RH									
Total kW	17.2	13.6	9.6	22.40	17.70	12.70	32.00	25.30	18.30
Sensible kW	17.2	13.6	9.6	22.40	17.70	12.70	32.00	25.30	18.30
Unit Power Input kW	0.92	0.92	0.92	1.70	1.70	1.70	3.02	3.02	3.02
Flow Rate, l/s	0.82	0.62	0.46	1.07	0.84	0.61	1.53	1.21	0.88
Pressure Drop, kPa	32	20	11	51.00	33.00	18.00	58.00	37.00	21.00
Supply Air Temp. °C	12.8	15.5	18.5	13.80	16.40	19.10	13.80	16.50	19.20
22°C DB - 55% RH									
Total kW	13.4	9	5.7	17.50	12.40	6.80	25.10	17.90	9.30
Sensible kW	12.6	9	5.7	17.00	12.40	6.80	24.00	17.90	9.30
Unit Power Input kW	0.92	0.92	0.92	1.70	1.70	1.70	3.02	3.02	3.02
Flow Rate, l/s	0.64	0.43	0.28	0.83	0.59	0.33	1.20	0.86	0.44
Pressure Drop, kPa	20	10	4	33.00	17.00	6.00	37.00	20.00	6.00
Supply Air Temp. °C	13.3	16.1	18.4	13.90	16.40	19.40	14.10	16.40	19.80
22°C DB - 50% RH									
Total kW	13.4	9	5.7	17.50	12.40	6.80	25.00	17.90	9.30
Sensible kW	13.4	9	5.7	17.00	12.40	6.80	25.00	17.90	9.30
Unit Power Input kW	0.92	0.92	0.92	1.70	1.70	1.70	3.02	3.02	3.02
Flow Rate, l/s	0.64	0.43	0.28	0.83	0.59	0.33	1.19	0.86	0.44
Pressure Drop, kPa	20	10	4	33.00	17.00	6.00	37.00	20.00	6.00
Supply Air Temp. °C	12.8	16.1	18.4	13.60	16.40	19.30	13.70	16.40	19.80

Note:

Performance declared with bottom connection and without humidifier and heaters
 Performance for 208V/1Ph/60Hz units are similar with 230V/1Ph/50V

Specifications

6.2 Electrical data

Wye vs. Delta Connection Power Supply for CRV

The Liebert CRV EC Fan Model is designed to operate with Wye-connected power. It will not operate properly with Delta connected power.

A field-supplied isolation transformer or other power solutions will be needed for proper function.

The electronically commutated motors included in the Liebert CRV are suitable for connection to power supplies with a solidly grounded neutral.

Fig. 6a Wye vs. Delta power supply connection diagram

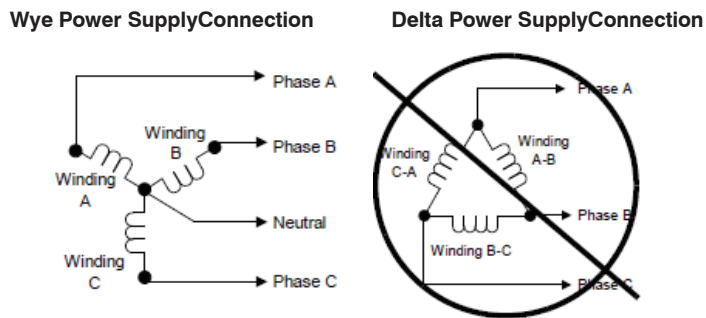

Acceptable Power Supplies-380V to 460V Nominal Units (TT System, TNS System or TNC System)

- 380V wye with solidly grounded neutral and 220V line-to-ground
- 460V wye with solidly grounded neutral and 277V line-to-ground.

Unacceptable Power Supplies-380V to 460V Nominal Units (IT System)

- Wye with high-resistance (or impedance) ground
- Delta without ground or with floating ground
- Delta with corner ground
- Delta with grounded center tap.

If the unit must be installed in the IT System, contact Vertiv Technical department prior to installation.

Tab. 6c - Electrical data

Configuration	Model	Unit Power supply	FLA [A]	LRA [A]	RESIDUAL-CURRENT CIRCUIT BREAKERS I _{Δn} = 0.3A (400V) (*)
Cooling <i>Fan+compressor</i>	CR011	230V/1ph/50Hz	16,1	23.10	25 A Curve C
	CR021	400V/3ph+N/50Hz	29,5	44.50	32 A Curve C
Cooling + Electrical heating (dehumidification) <i>Fan +compressor + electrical heaters</i>	CR011	230V/1ph/50Hz	36,0	43.00	40 A Curve C
	CR021	400V/3ph+N/50Hz	36,0	51.00	40 A Curve C
Cooling + Humidification <i>Fan + compressor+ humidifier</i>	CR011	230V/1ph/50Hz	22,6	29.60	40 A Curve C
	CR021	400V/3ph+N/50Hz	36,0	51.00	40 A Curve C

Specifications

Configuration	Model	Unit Power supply	FLA [A]	LRA [A]	RESIDUAL-CURRENT CIRCUIT BREAKERS I Δ n = 0.3A (400V) (*)
Cooling Fan	CR032RC	230V/1ph/50Hz	6.3	0.3	16 A Curve C
	CR038RC		8.4	0.4	
	CR060RC		12.6	0.6	
Cooling + Electrical heating (post heating during dehumidification) Fan + electrical heaters	CR032RC	400V/3ph+N/50Hz	8.6	6.7	
	CR038RC		10.7	6.9	
	CR060RC		10.7	6.9	
Cooling + Humidification Fan + humidifier	CR032RC	400V/3ph+N/50Hz	8.6	6.7	
	CR038RC		8.6	6.6	
	CR060RC		10.7	6.7	

(*) **ATTENTION:** Only universal (type B, B+) RCD protective devices are permitted.

COMPONENT	UNIT POWER SUPPLY	MODEL	OA (*) [A]	FLA (**) [A]	LRA (**) [A]	NOMINAL POWER [kW]
FAN	230 V/1 PH/50 Hz	CR011	3x0.97	3x1.7	3x1.7	3x0.23
		CR021	5x1.07	5x1.7	5x1.7	5x0.23
		CR032	3x1.69	3x2.1	3x2.1	3x0.48
		CR038	4x1.69	4x2.1	4x2.1	4x0.48
		CR060	6x2.09	6x2.1	6x2.1	6x0.48
COMPRESSOR	230 V/1 PH/50 Hz	CR011	3.05	11	18	2.72
	400 V/3 PH+N/50 Hz	CR021	7.44	21	36	4.66
HUMIDIFIER	230 V/1 PH/50 Hz	CR011	6.5	6.5	-	1.5
		CR021	6.5	6.5	-	1.5
		CR032	6.5	6.5	-	1.5
		CR038	6.5	6.5	-	1.5
		CR060	6.5	6.5	-	1.5
ELECTRICAL HEATER	230 V/1 PH/50 Hz	CR011	19.57	19.57	-	4.5
		CR021	6.5	6.5	-	4.5
		CR032	6.5	6.5	-	4.5
		CR038	6.5	6.5	-	4.5
		CR060	6.5	6.5	-	4.5
CONDENSATE PUMP	230 V/1 PH/50 Hz	CR011	-	0.8	-	0.075
		CR021	-	0.8	-	0.075
		CR032	-	0.8	-	0.075
		CR038	-	0.8	-	0.075
		CR060	-	0.8	-	0.075

Specifications

6.3 Sound data

Tab. 6d - Liebert CRV Sound Data

The following tables show sound levels for every octave band frequency.

CR011 Air Cooled Tested

Fan Speed %	Airflow m ³ /h	Octave band frequency (Hz)										Sound Level [dB(A)]	Unit SPL suction (2m, f.f., dBA)
		Level	31.5	63	125	250	500	1000	2000	4000	8000		
100	3128	PWL	79.3	79.3	81.8	81	80.8	77.6	79.8	74.8	67.8	84.8	71.9
80	2700		75.5	75.5	78	77.2	77	73.8	76	71	64	81	69.2
50	1527		63.5	63.5	66	65.2	65	61.8	64	59	52	69	65.3

CR021 Air Cooled Tested

Fan Speed %	Airflow m ³ /h	Octave band frequency (Hz)										Sound Level [dB(A)]	Unit SPL suction (2m, f.f., dBA)
		Level	31.5	63	125	250	500	1000	2000	4000	8000		
100	4630	PWL	80.1	80.1	82.6	81.8	81.6	78.4	80.6	75.6	68.6	85.6	72.6
85	4050		77.4	77.4	79.9	79.1	78.9	75.7	77.9	72.9	65.9	82.9	69.1
50	2183		64.7	64.7	67.2	66.4	66.2	63	65.2	60.2	53.2	70.2	64.5

CR032

Fan Speed %	Airflow m ³ /h	Octave band frequency (Hz)										Sound Level [dB(A)]	Unit SPL suction (2m, f.f., dBA)
		Level	31.5	63	125	250	500	1000	2000	4000	8000		
100	4000	PWL	64.6	71.1	75.8	85.8	90.2	92	90.6	86.5	78.6	96.3	73.1
75	3000		56.9	63.4	68.1	78.1	82.5	84.3	82.9	78.8	70.9	88.6	65.4
60	2400		52.1	58.6	63.3	73.3	77.7	79.5	78.1	74	66.1	83.8	60.6

CR038

Fan Speed %	Airflow m ³ /h	Octave band frequency (Hz)										Sound Level [dB(A)]	Unit SPL suction (2m, f.f., dBA)
		Level	31.5	63	125	250	500	1000	2000	4000	8000		
100	5520	PWL	66	72,5	77,2	87,2	91,6	93,4	92	87,9	80	97,7	74,5
75	4140		60,5	67	71,7	81,7	86,1	87,9	86,5	82,4	74,5	92,2	69
60	3273		55,2	61,7	66,4	76,4	80,8	82,6	81,2	77,1	69,2	86,9	63,7

CR060

Fan Speed %	Airflow m ³ /h	Octave band frequency (Hz)										Sound Level [dB(A)]	Unit SPL suction (2m, f.f., dBA)
		Level	31.5	63	125	250	500	1000	2000	4000	8000		
100	7670	PWL	68,8	75,3	80,0	90,0	94,4	96,2	94,8	90,7	82,8	100,5	77,3
75	5752		63,1	69,6	74,3	84,3	88,7	90,5	89,1	85,0	77,1	94,8	71,6
55	4240		56,8	63,3	68,0	78,0	82,4	84	82,8	78,7	70,8	88,5	65,3

7

Heat Rejections (A version)

7.1 Coupling of Liebert CRV (A-type, 50Hz, CE mark) air conditioning units with remote air-cooled condensers (HCR - MCC)

HCR and MCC condensers are especially designed to be coupled with the Liebert CRV (A type) air conditioning units power supplied at 50Hz (CE market), within a standard range of external air temperature from -20 °C to +46 °C.

The HCR and MCC family comes with a factory-installed stepless fan speed controller especially designed and setted for usage with R410A refrigerant and digital scroll refrigerant circuit.

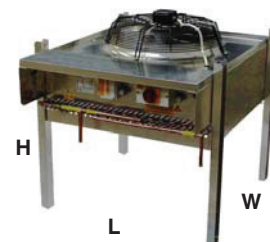

Tab. 7a - Coupling of Liebert HCR Condensers with Liebert CRV 300DX air conditioning units

MODEL	External temperature up to 35 °C		External temperature up to 40 °C		External temperature up to 46 °C	
	standard noise	low noise	standard noise	low noise	standard noise	low noise
CR011RA	1 x HCR17	1 x HCR33	1 x HCR33	1 x HCR43	1 x HCR43	1 x HCR51
CR021RA	1 x HCR33	1 x HCR43	1 x HCR43	1 x HCR51	1 x HCR51	1 x HCR59

Tab. 7b - Coupling of Liebert® MCC Premium Condensers with Liebert® CRV 300DX

MODEL	External temperature up to 35 °C	External temperature up to 40 °C	External temperature up to 46 °C
	standard noise	standard noise	standard noise
CR011RA	1 x MCS028	1 x MCM040	1 x MCM040
CR021RA	1 x MCM040	1 x MCM055	1 x MCL055

Tab. 7c - Coupling of Liebert® MCC Basic Condensers with Liebert® CRV 300DX

MODEL	External temperature up to 35 °C	External temperature up to 40 °C	External temperature up to 46 °C
	standard noise	standard noise	standard noise
CR011RA	1 x MCS028	1 x MCM035	1 x MCM040
CR021RA	1 x MCM035	1 x MCM040	1 x MCL055

The table shows the recommended combinations of the Air cooled Condensers (50Hz - CE mark) with the air conditioners Liebert CRV (50Hz - CE mark), according to the indicated max external air temperature.

Connecting a too large capacity condenser (50% higher than the nominal capacity indicated in Tab. 7a) to the CRV unit can cause malfunctioning and incorrect condenser regulation at low ambient temperature (e.g. in cold season).

The above indications are approximate and must be checked on the basis of other specific operating conditions.

For operating conditions other than those indicated in the table, refer to the New Hiring calculation software and to the air condenser service manual.

Heat Rejections (A version)

Tab. 7d - Technical data and performance of air-cooled condenser Liebert HCR

Model	Power supply [V/Ph/Hz]	Total Heat Rejection (THR)* R410A [kW]	Air Volume [m ³ /h]	Noise Level ** [dB(A)] @ 5 m, f.f.	Input Power [kW]	Current Absorption [A]	FLA [A]	Refrigerant connections [mm]		Dimensions [mm]	Weight [kg]
								Gas line [mm]	Liquid line [mm]		
HCR17	230/1/50	17.0	4410	44.5	0.27	1.2	1.2	16	16	W 1120 D 856 H 934	60
HCR24	230/1/50	23.98	8600	50.0	0.55	2.5	2.6	16	16	W 1340 D 831 H 1112	60
HCR33	230/1/50	32.2	7400	50.0	0.55	2.5	2.6	16	16	W 1340 D 831 H 1112	75
HCR43	230/1/50	46.0	17000	53.0	1.10	5.0	5.2	16	16	W 2340 D 831 H 1112	92
HCR51	230/1/50	52.0	17000	53.0	1.10	5.0	5.2	22	16	W 2340 D 831 H 1112	93
HCR59	230/1/50	62.0	15600	53.0	1.10	5.0	5.2	22	16	W 2340 D 831 H 1112	102
HCR76	230/1/50	78.0	25500	55.0	1.65	7.5	7.8	22	16	W 3340 D 831 H 1112	136
HCR88	230/1/50	92.0	23400	55.0	1.65	7.5	7.8	22	16	W 3340 D 831 H 1112	165
HCR99	230/1/50	130.0	32000	57.0	2.20	10.0	10.0	28	22	W 4338 D 831 H 1112	220

Heat Rejections (A version)

Tab. 7e - Technical data and performance of air-cooled condenser Liebert HCR 3ph

Model	Power supply [V/Ph/Hz]	Total Heat Rejection (THR)* R410A [kW]	Air Volume [m ³ /h]	Noise Level ** [dB(A)] @ 5 m, f.f.	Input Power [kW]	Current Absorption [A]	FLA [A]	Refrigerant connections [mm]		Dimensions [mm]	Weight [kg]
								Gas line [mm]	Liquid line [mm]		
HCR24	400/3/50	23.75	8600	53.0	0.55	1.3	1.3	16	16	W 1340 D 831 H 1112	60
HCR33	400/3/50	31.49	7400	53.0	0.55	1.3	1.3	16	16	W 1340 D 831 H 1112	75
HCR43	400/3/50	45.84	17000	56.0	1.10	2.4	2.4	16	16	W 2340 D 831 H 1112	92
HCR51	400/3/50	51.5	17000	56.0	1.10	2.4	2.4	22	16	W 2340 D 831 H 1112	93
HCR59	400/3/50	61.03	15600	56.0	1.10	2.4	2.4	22	16	W 2340 D 831 H 1112	102
HCR76	400/3/50	78.0	25500	58.0	1.65	3.6	3.6	22	16	W 3340 D 831 H 1112	136
HCR88	400/3/50	92.0	23400	58.0	1.65	3.6	3.6	22	16	W 3340 D 831 H 1112	165
HCR99	400/3/50	116.5	33200	59.0	2.20	4.8	4.8	28	22	W 4338 D 831 H 1112	220

Heat Rejections (A version)

Tab. 7f - Technical data and performance of air-cooled condenser Liebert MC Premium

Model	Power supply [V/Ph/Hz]	Total Heat Rejection (THR)* R410A [kW]	Air Volume [m³/h]	Noise Level ** [dB(A)] @ 5 m, f.f.	Input Power [kW]	Current Absorption [A]	FLA [A]	Refrigerant connections [mm]		Dimensions [mm]	Weight [kg]
								Gas line [mm]	Liquid line [mm]		
MCS028	230/1/50	32.96	8831	49.8	0.473	0.99	4.3	22	22	W 1283 D 1180 H 955	70
MCM040	400/3/50	41.97	11264	540	0.636	1.23	1.5	22	22	W 1381 D 972 H 1269	105
MCL055	400/3/50	59.55	15451	6,200	0.920	1.72	3.5	28	28	W 1676 D 1509 H 1105	156
MCM080	400/3/50	83.94	22528	5,700	1.272	2.46	3	28	28	W 2602 D1269 H 972	200
MCL110	400/3/50	112	30902	6,500	2.11	3.96	7	35	35	W 3102 D 1509 H 1102	273
MCM160	400/3/50	168	45056	6,000	2.54	4.92	6	28	28	W 5045 D 1269 H 972	380
MCL165	400/3/50	179	46353	6,800	3.68	2.76	10.5	35	35	W 4527 D 1509 H 1105	404

Heat Rejections (A version)

Tab. 7g - Technical data and performance of air-cooled condenser Liebert MC Basic

Model	Power supply [V/Ph/Hz]	Total Heat Rejection (THR)* R410A [kW]	Air Volume [m³/h]	Noise Level ** [dB(A)] @ 5 m, f.f.	Input Power [kW]	Current Absorption [A]	FLA [A]	Refrigerant connections [mm]		Dimensions [mm]	Weight [kg]
								Gas line [mm]	Liquid line [mm]		
MCS028	230/1/50	29.6	7452	50.10	0.47	1.73	2.30	22	22	W 1283 D 1180 H 955	70
MCM035	230/1/50	34.50	8000	50.10	0.47	1.73	2.30	22	22	W 1381 D 972 H 1269	105
MCM040	230/1/50	44.78	10600	52.00	0.78	3.75	440	22	22	W 1381 D 972 H 1269	105
MCL055	400/3/50	58.60	16250	53.50	1.60	3.60	4.40	28	28	W 1676 D 1509 H 1105	156
MCM070	230/1/50	69.00	16000	53.10	0.94	3.46	8.80	35	35	W 2602 D 1269 H 972	200
MCM080	230/1/50	89.56	21200	55.00	1.55	7.50	8.80	35	35	W 2602 D 1269 H 972	200
MCL110	400/3/50	117.20	32500	57.00	3.20	7.20	8.80	35	35	W 3102 D 1509 H 1102	273
MCM160	230/1/50	179.12	42400	6,000	3.10	15.00	17.60	28	28	W 5045 D 1269 H 972	380
MCL165	400/3/50	175.80	48750	66.80	4.80	10.8	13.2	35	35	W 4527 D 1509 H 1105	404

Heat Rejections (A version)

(*) The nominal heat rejection capacities refer to the following operative conditions:

- refrigerant R410A
- temperature differences: 15 K
- (T condensation dew point - Toutdoor).
- liquid sub-cooling 3K
- height of the installation = 0 m, above the sea level.
- for different conditions refer to New Hirating program.
- clean exchange surfaces.

(**) The levels of sound pressure here included are measured in the same operative conditions, and are referred to 5 m far from the unit, at 1.5 m in height, in free field conditions.

All air remote condensers are:

- CE marked.
- Conform to the following European Directives:
MD: 2006/42/EC;
EMC: 2014/30/EU;
LVD: 2014/35/EU;
PED: 2014/68/EU.
- Frame is made up of a sturdy aluminum structure.
- Units are factory equipped with electric board, with main disconnecter IP65 and with stepless fan speed controller.
The entire units have IP54 type of protection.
- Motorized fans are IP54 (DIN60529) , protection class F.
Maintenance-free ball bearings.
- Most important technical data are gathered in Chap. 7.
- Heat rejection capacity have been measured according to the norm EN327.
Sound power level have been measured according to the norm UNI EN ISO 3741:2001.
Sound pressure level have been evaluated according to the norm EN13487, at 5m distance, with free field conditions.
- Max working pressure is 43 barg.

Fig. 8a Overall dimensions / service area

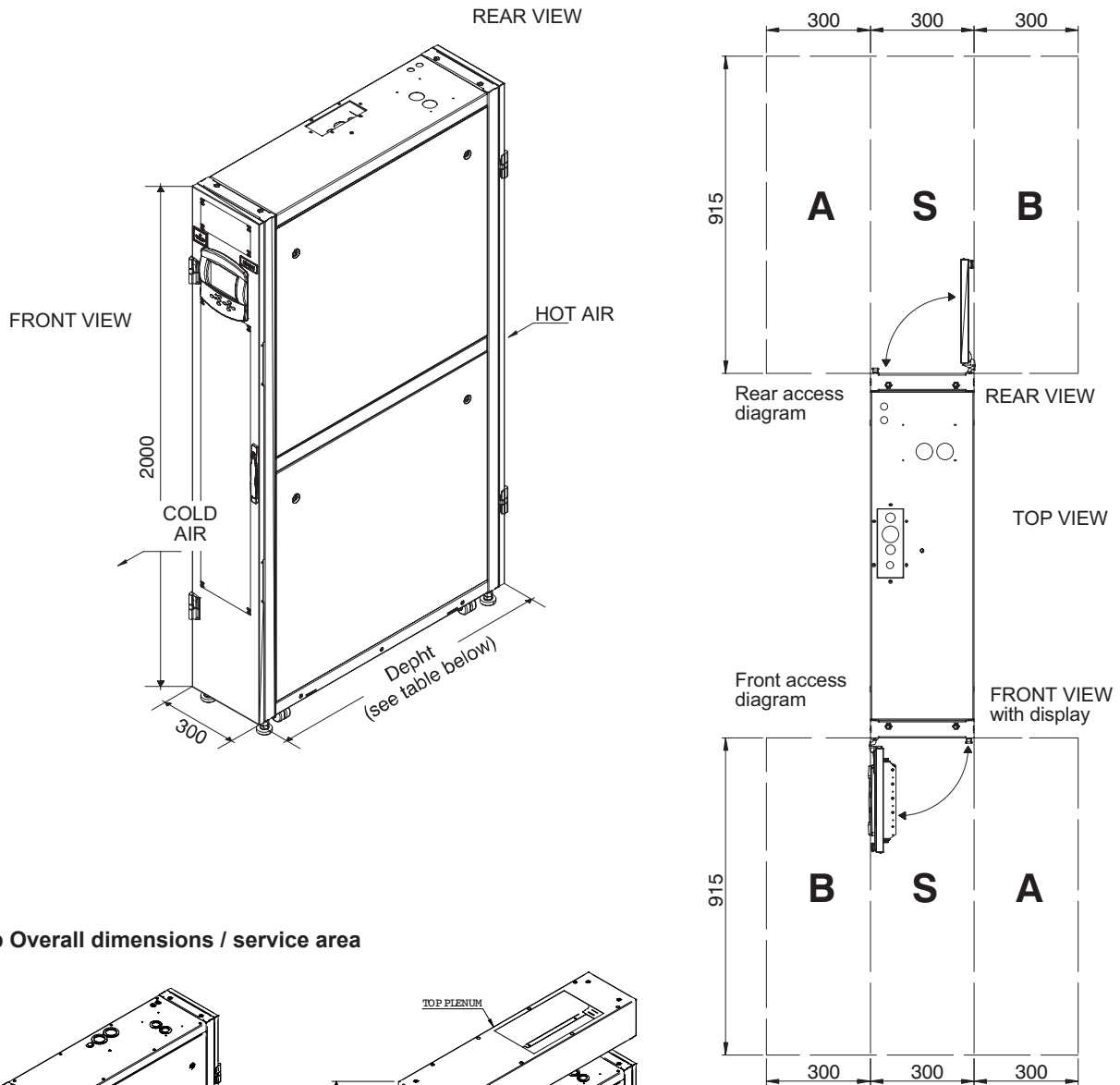
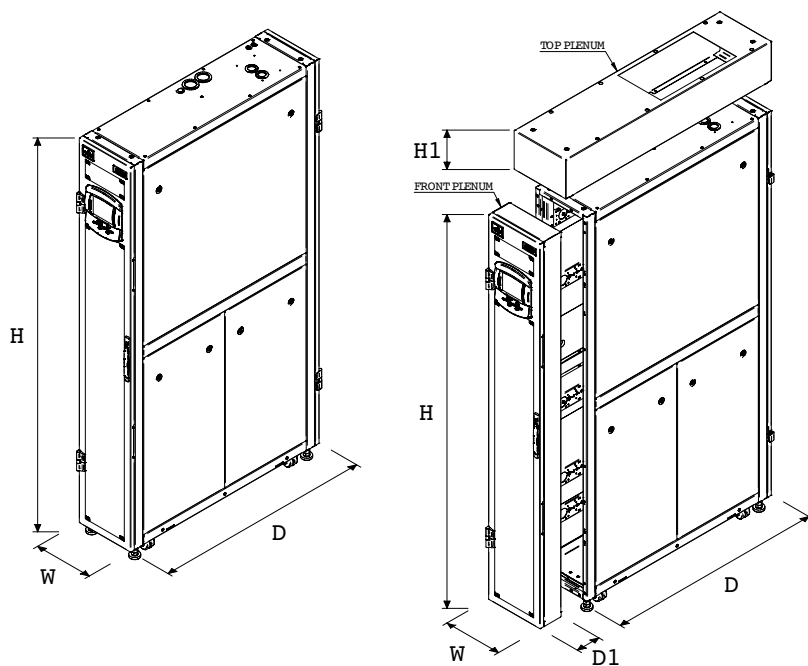
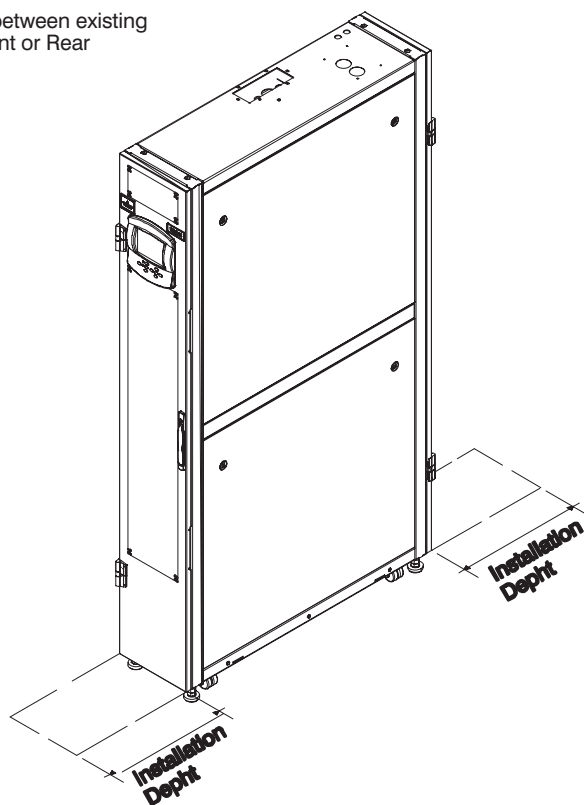

Fig. 8b Overall dimensions / service area



Installation drawings

Access required to install the unit between existing racks within the row only Front or Rear clearance required



Tab. 8a - Overall dimensions - DX

Models	Height mm	Depth mm	Installation depth mm	Weight kg
CR11RA	2000	1100 / 1200	1250	220
CR21RA	2000	1100 / 1200	1250	230

Tab. 8b - Overall dimensions - CW

Models	H mm	H1 mm	D mm	D1 mm	W mm	Weight kg
CR032RC	2000	222	1100 / 1200	100	300	200
CR038RC	2000	222	1100 / 1200	100	300	210
CR060RC	2000	222	1100 / 1200	100	300	230

Installation drawings

Fig. 8c Hole on the raised floor for piping - DX

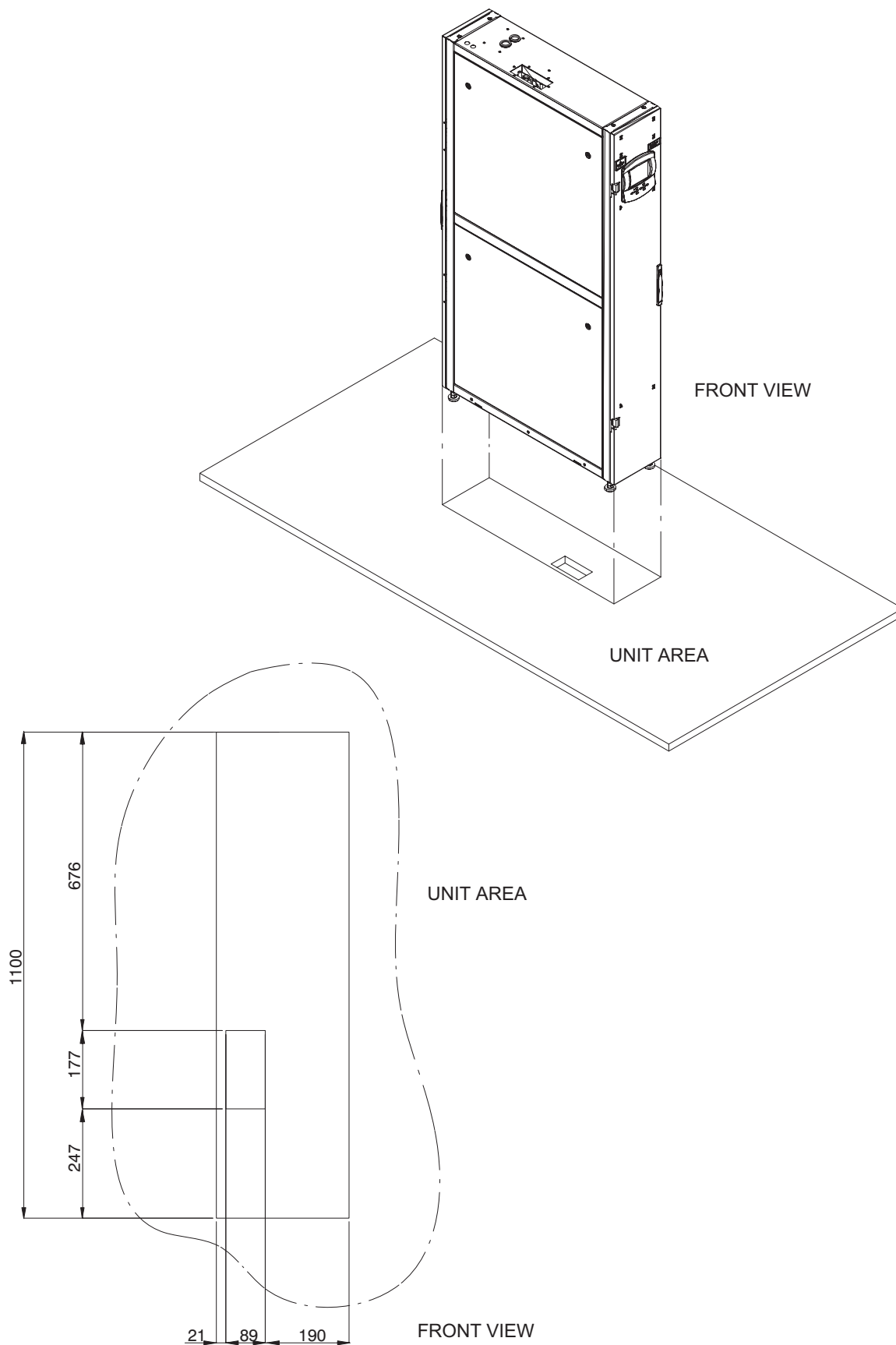

Installation drawings

Fig. 8d Hole on the raised floor for piping - CW

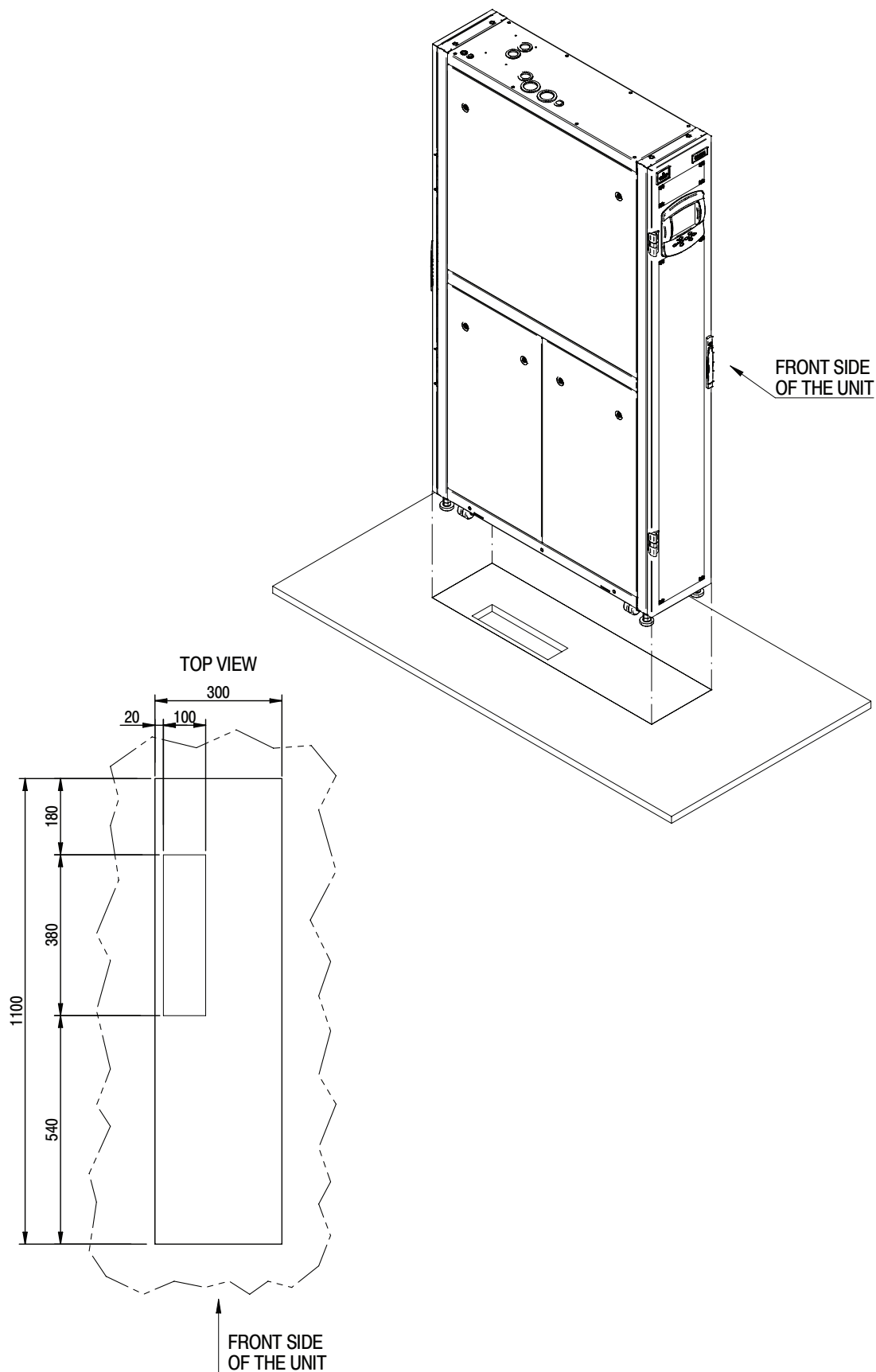

Installation drawings

Fig. 8e Air bleeding valve position CW

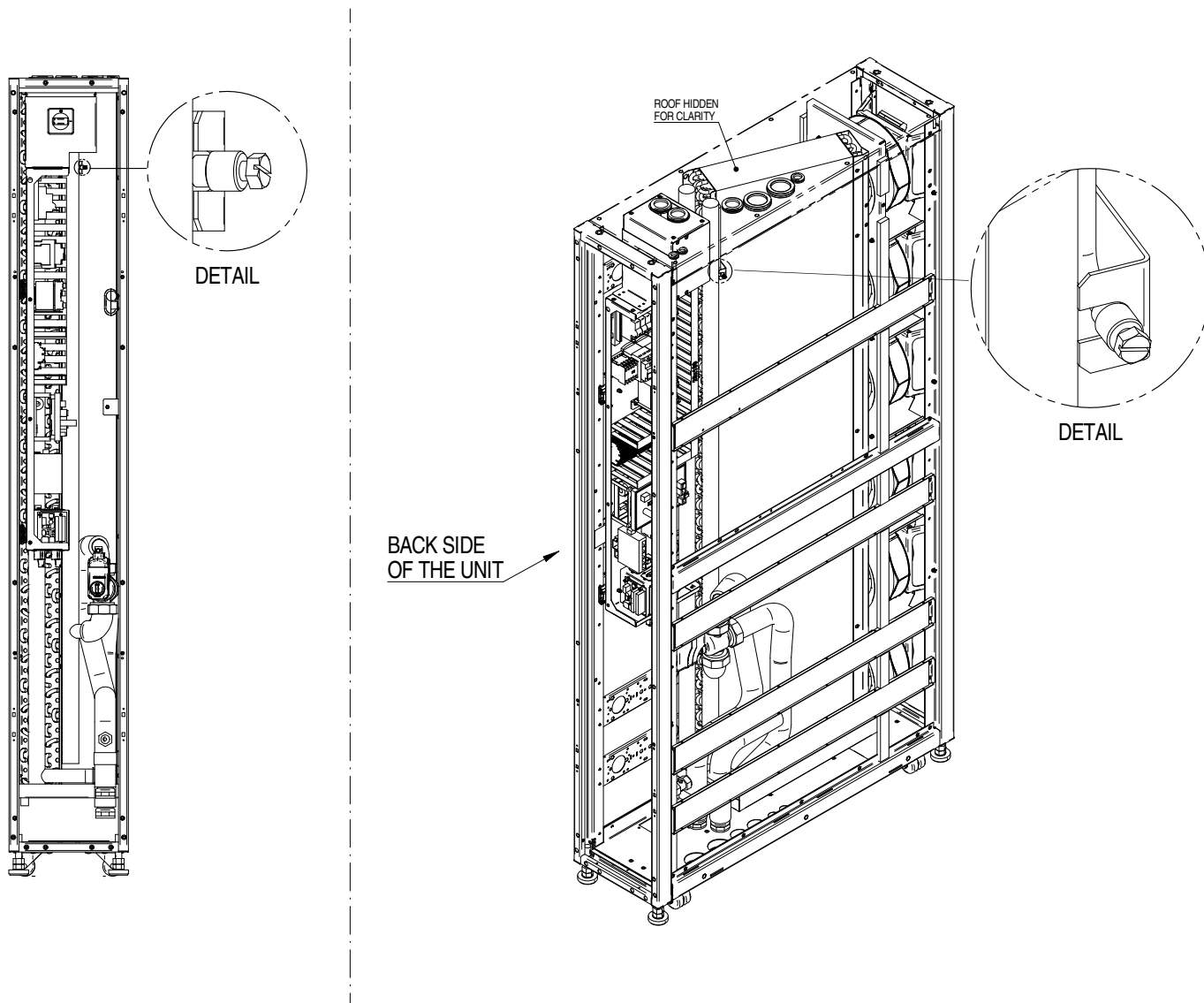

Installation drawings

Fig. 8f Electrical connections - entry - DX

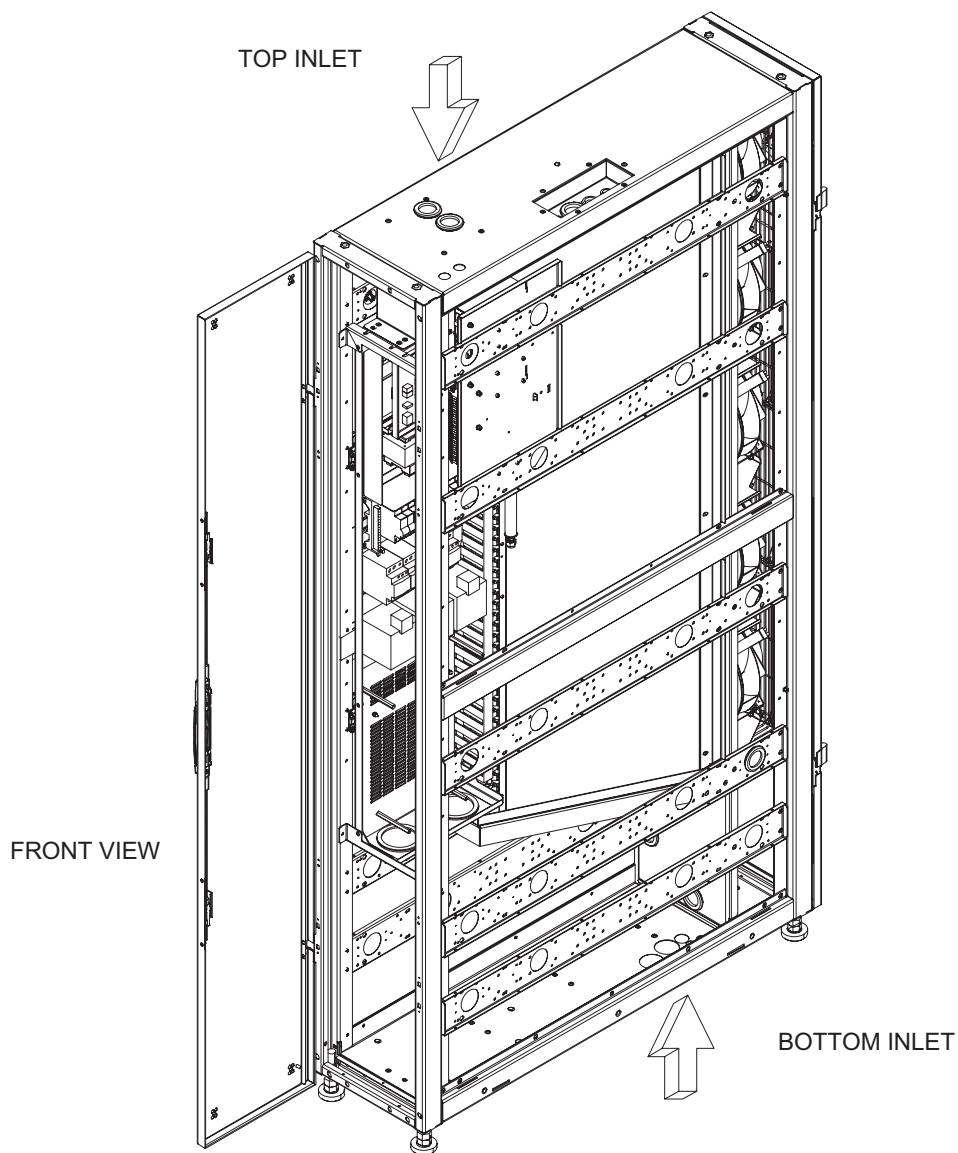

Installation drawings

Fig. 8g Electrical connections - entry - CW

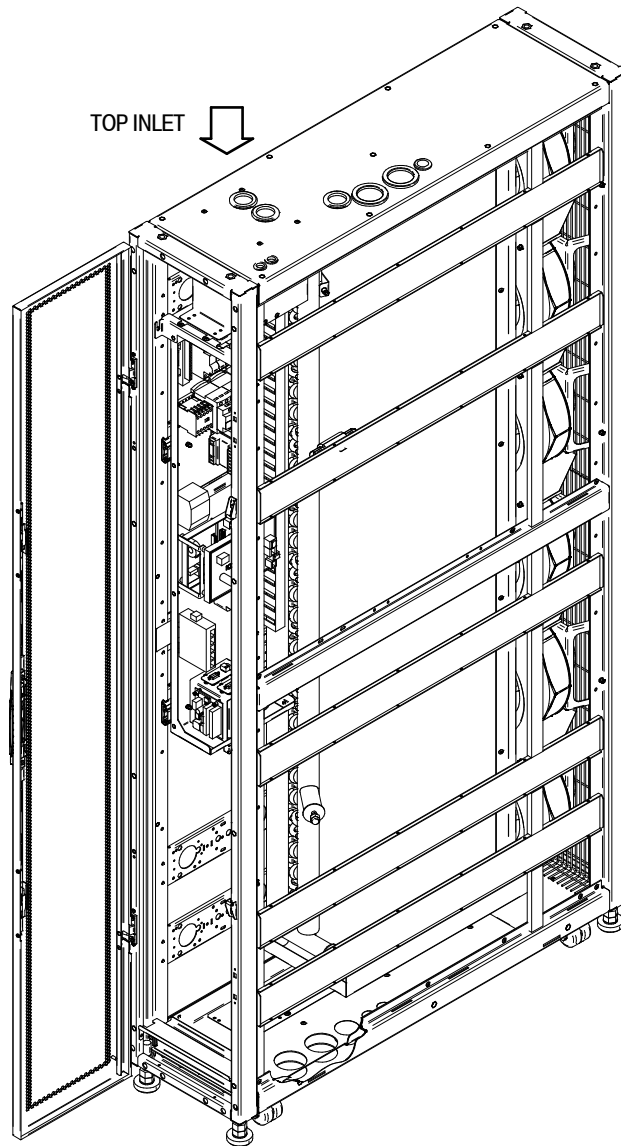

9

Refrigerant, Hydraulic and Electrical Connections

Fig. 9a CR011RA - CR021RA connections

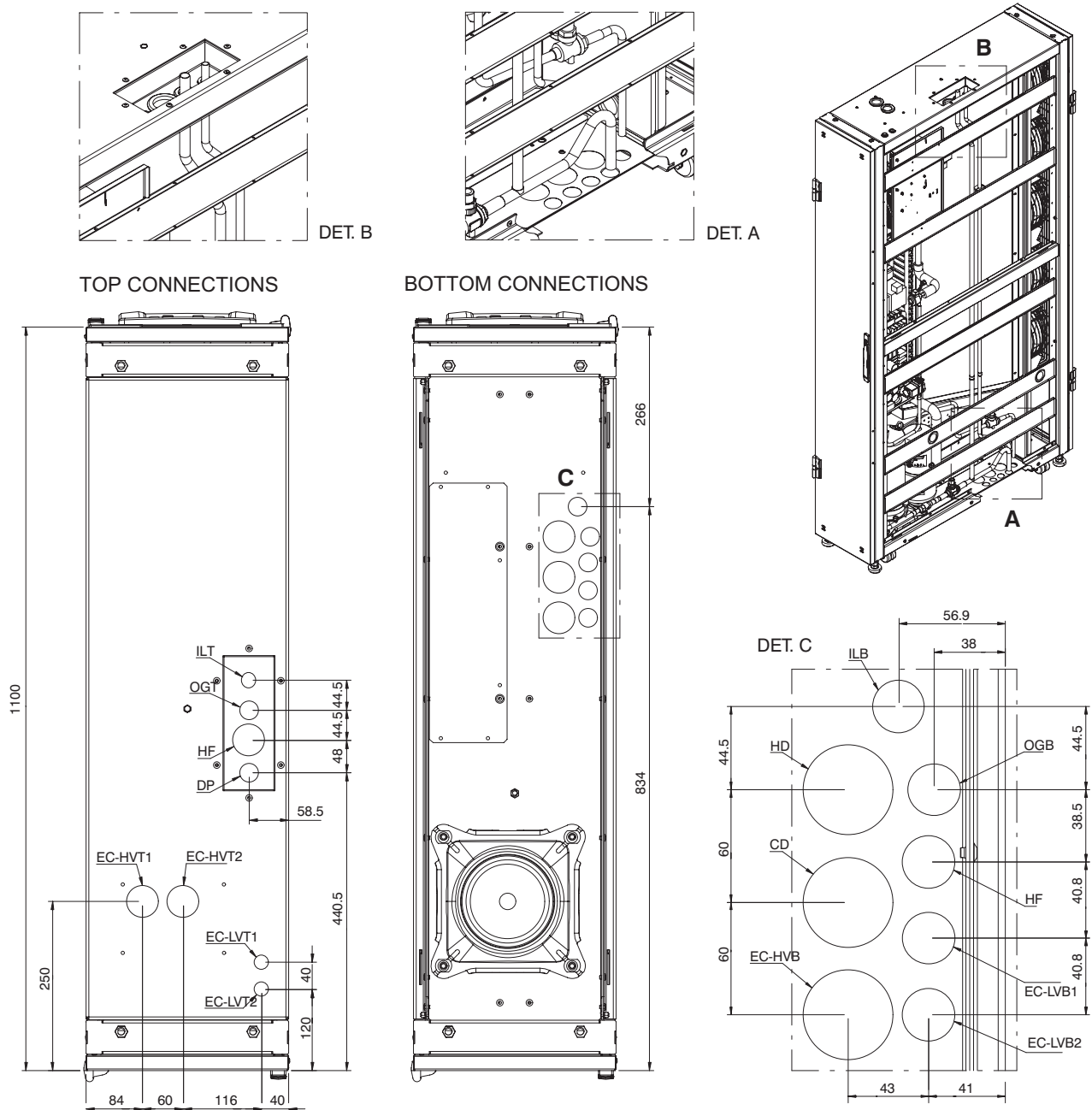

Unit Top Connection		CR011RA-CR21RA	Unit Bottom Connection		CR011RA-CR21RA
ILT	Refrigerant liquid line inlet ISO 7/1	OD 12 (Rp 1/2) CU SWEAT	ILB	Refrigerant liquid line inlet ISO 7/1	OD 12 (Rp 1/2) CU SWEAT
OGT	Refrigerant gas line outlet ISO 7/1	OD 16 (Rp 5/8) CU SWEAT	OGB	Refrigerant gas line outlet ISO 7/1	OD 16 (Rp 5/8) CU SWEAT
CD	Condensate drain - ISO 7/1		CD	Condensate drain - ISO 7/1	ID 48
HF	Humidifier feed (opt.) - ISO 7/1	Rp 1/2	HF	Humidifier feed (opt.) - ISO 7/1	ID 28
HD	Humidifier drain - ISO 7/1		HD	Humidifier drain - ISO 7/1	ID 48
DP	Pump drain - ISO 7/1	Rp 5/8	DP = CD or HD	Pump drain - ISO 7/1	ID 48
EC-HV1T	Electrical supply - high voltage	ID 48	EC-HVB	Electrical supply - high voltage	ID 48
EC-HV2T	Electrical supply - high voltage	ID 48			
EC-LV1T	Electrical supply - low voltage	ID 22	EC-LV1B	Electrical supply - low voltage	ID 28
EC-LV2T	Electrical supply - low voltage	ID 22	EC-LV2B	Electrical supply - low voltage	ID 28

Refrigerant, Hydraulic and Electrical Connections

Fig. 9b CR032RC - CR060RC connections

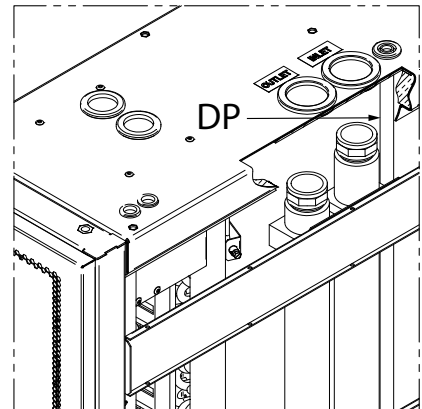
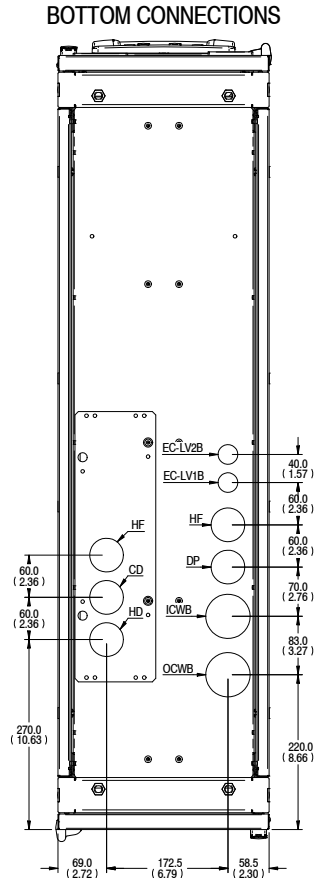
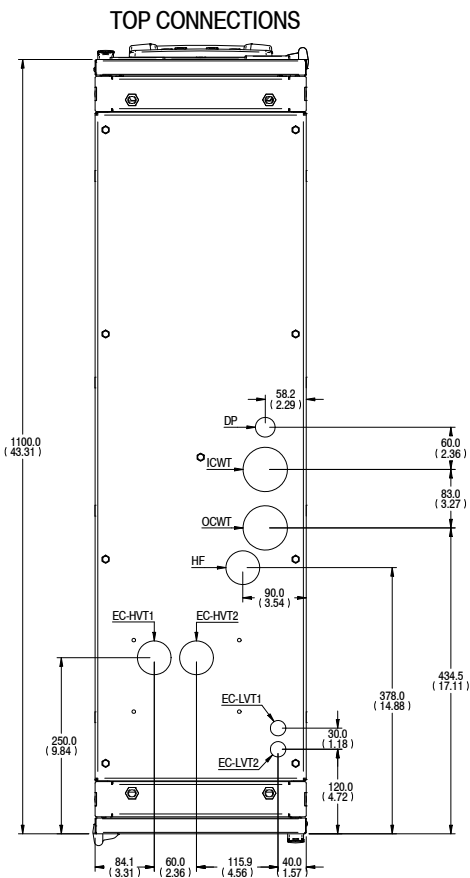

TOP CHILLED WATER CONNECTIONS

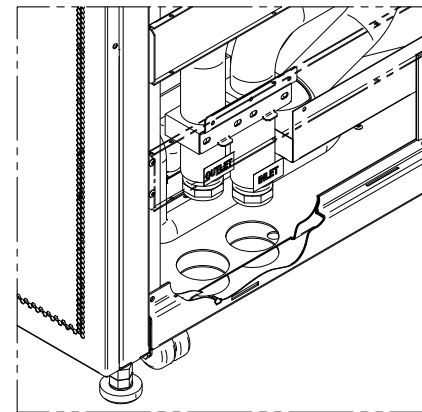

REAR BOTTOM CHILLED WATER CONNECTIONS

Unit Top Connections		CR032RC - CR060RC	Unit Bottom Connections		CR032RC - CR060RC
ICWT	Chilled water inlet ISO 7/1	RP 1 1/4	ICWB	Chilled water inlet ISO 7/1	RP 1 1/4
OCWT	Chilled water outlet ISO 7/1	RP 1 1/4	OCWB	Chilled water outlet ISO 7/1	RP 1 1/4
			CD	Condensate drain ISO 7/1	ID 48
HF	Humidifier feed (opt.) ISO 7/1	RP 1/2 for top connections	HF	Humidifier feed (opt.) ISO 7/1	ID 48
			HD	Humidifier drain ISO 7/1	ID 48
DP	Pump drain ISO 7/1	RP 5/8	DP = CD or HD	Pump drain ISO 7/1	ID 48
EC-HVT1	Electrical supply High voltage	ID 48			
EC-HVT2	Electrical supply High voltage	ID 48			
EC-LVT1	Electrical supply Low voltage	ID 22	EC-LVB1	Electrical supply Low voltage	ID 28
EC-LVT2	Electrical supply Low voltage	ID 22	EC-LVB2	Electrical supply Low voltage	ID 28

Refrigerant, Hydraulic and Electrical Connections

Fig. 9c DX electrical board layout

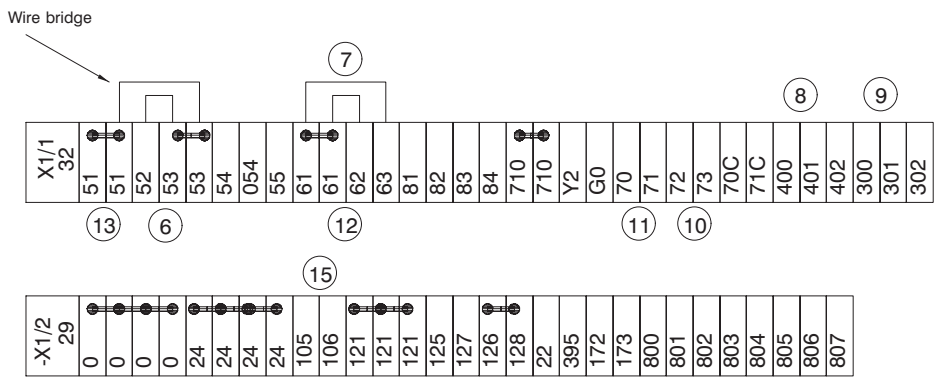
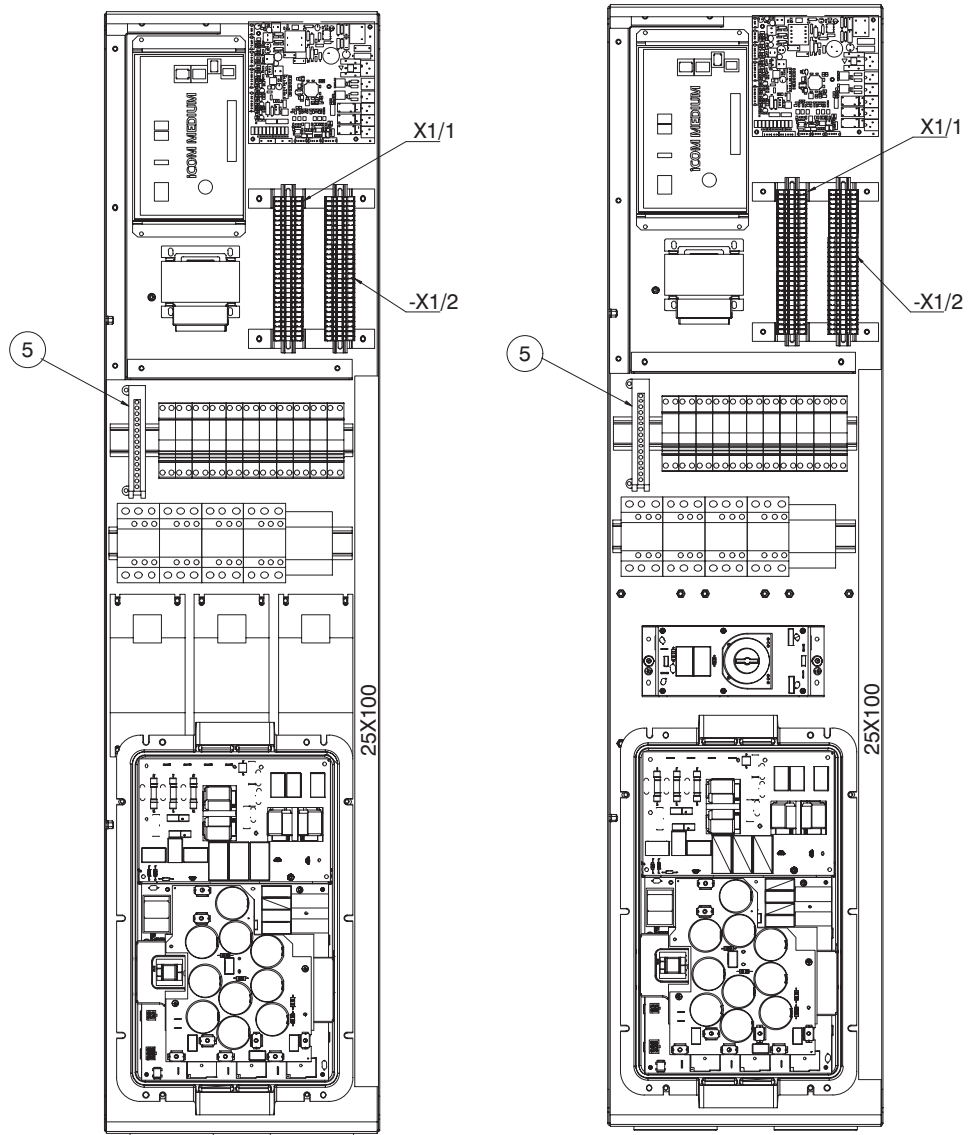

Refrigerant, Hydraulic and Electrical Connections

9.1 DX electrical field connections descriptions - 50 Hz

STANDARD ELECTRICAL CONNECTIONS

1. **Primary high voltage entrance** Quantity (2) 28mm diameter concentric knockouts located in bottom of box
2. **Secondary high voltage entrance** Quantity (2) 35mm diameter concentric knockouts located in top of box
3. **Primary low voltage entrance** Quantity (1) 18mm diameter knockouts located in bottom of unit
4. **Secondary low voltage entrance** Quantity (2) 22mm diameter knockouts located in top of box
5. **Earth ground** - Terminal for field supplied earth grounding wire.
6. **Remote unit shutdown** - Replace existing jumper between terminals 52 & 53 with field supplied normally closed switch having a minimum 75VA, 24VAC rating. Use field supplied Class 1 wiring.
7. **Customer alarm inputs** - Terminals for field supplied, normally closed contacts, having a minimum 75VA, 24VAC rating, between terminals 61 & 63. Use field supplied Class 1 wiring.
8. **General alarm** - On any alarm, normally open dry contact is closed across terminals 400,401 for remote indication. 2 AMP, 24VAC max load. Use Class 1 field supplied wiring.
9. **Warning alarm** - On any alarm, normally open dry contact is closed across terminals 300,301 for remote indication. 2 AMP, 24VAC max load. Use Class 1 field supplied wiring.
10. **Compressor motor on** - On any call for compressor operation, normally open dry contact is closed across terminals 72 & 73, 2 AMP, 24VAC max load. Use Class 1 field supplied wiring.
11. **Fan motor on** - On any call for fans operation, normally open dry contact is closed across terminals 70 & 71. 2 AMP, 24VAC max load. Use Class 1 field supplied wiring.

OPTIONAL ELECTRICAL CONNECTIONS

12. **Smoke sensor alarm** (with smoke sensor option)- The smoke sensor is factory installed ,and senses the delivery air;it is connected across terminals 61-62 and send a visual and an audible alarm.
This smoke sensor is not intended to function as, or replace, any room smoke detection system that may be required by local or national codes. 1 AMP, 24VAC max load. Use Class 1 field supplied wiring.
13. **Condensate alarm** (with condensate pump option) - On pump high water indication, normally open dry contact is closed across purple wire for remote indication install inside the box near the pump. 1 AMP, 24VAC max load. Use Class 1 field supplied wiring.

OPTIONAL LOW VOLTAGE TERMINAL PACKAGE CONNECTIONS

14. **Flooding alarm** (liquistat) - The flooding alarm detects the presence of water and activate an alarm. The sensor is connect across terminals 105 & 106 and up to 5 sensors can be connected to the same flooding alarm device,to control many points in the bottom of the unit.

Refrigerant, Hydraulic and Electrical Connections

Fig. 9c CW electrical board layout

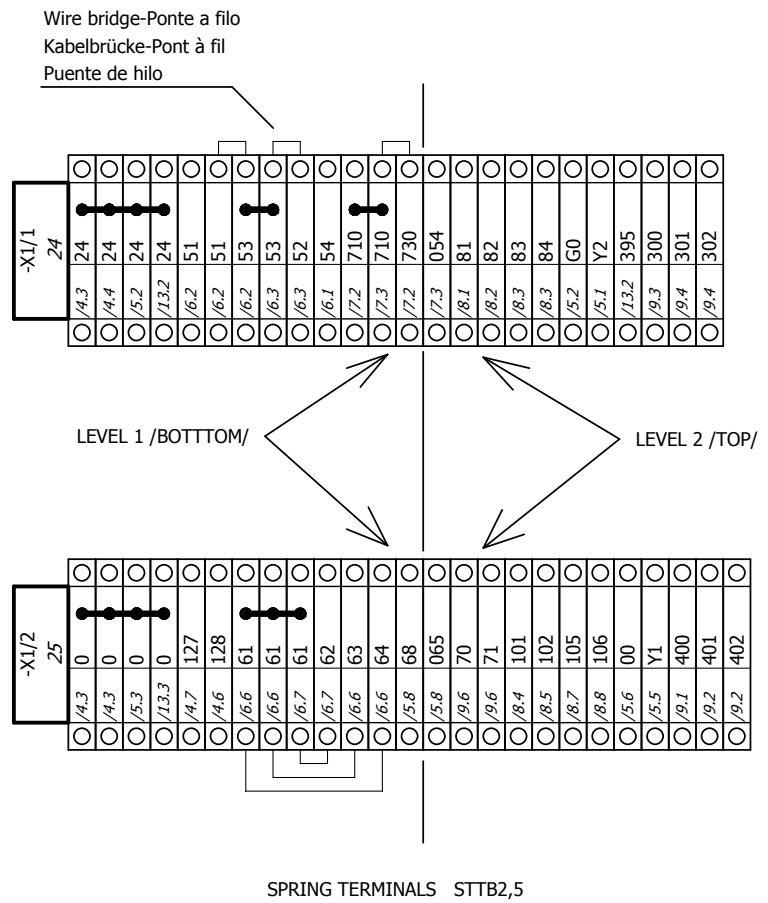
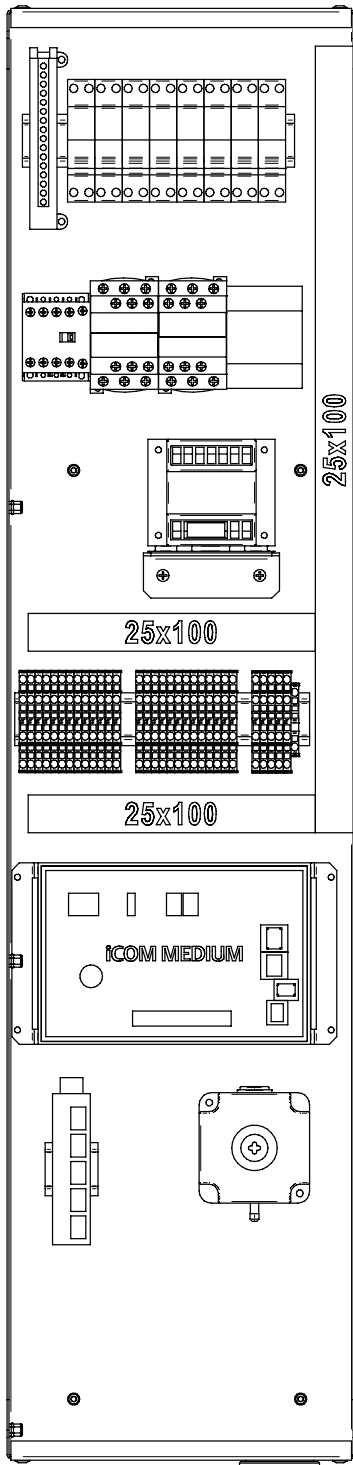

Refrigerant, Hydraulic and Electrical Connections

9.2 CW electrical field connections descriptions - 50 Hz

STANDARD ELECTRICAL CONNECTIONS

1. Primary high voltage entrance Quantity (2) 28mm diameter concentric knockouts located in bottom of box
2. Secondary high voltage entrance Quantity (2) 35mm diameter concentric knockouts located in top of box
3. Primary low voltage entrance Quantity (1) 18mm diameter knockouts located in bottom of unit
4. Secondary low voltage entrance " Quantity (2) 22mm diameter knockouts located in top of box
5. Earth ground - Terminal for field supplied earth grounding wire(0.25 ÷ 6mm²).
6. Remote unit shutdown - Replace existing jumper between terminals 52 & 53 with field supplied normally closed switch having a minimum 75VA, 24VAC rating. Use field supplied Class 1 wiring.
7. Customer alarm inputs - Terminals for field supplied, normally closed contacts, having a minimum 75VA, 24VAC rating, between terminals 61 & 63. Use field supplied Class 1 wiring.
8. General alarm - On any alarm, normally open dry contact is closed across terminals 400,401 for remote indication. 2 AMP, 24VAC max load. Use Class 1 field supplied wiring.
9. Warning alarm - On any alarm, normally open dry contact is closed across terminals 300,301 for remote indication. 2 AMP, 24VAC max load. Use Class 1 field supplied wiring.
10. Fan motor on - On any call for fans operation, normally open dry contact is closed across terminals 70 & 71. 2 AMP, 24VAC max load. Use Class 1 field supplied wiring.

OPTIONAL ELECTRICAL CONNECTIONS

11. Smoke sensor alarm (with smoke sensor option)- The smoke sensor is factory installed ,and senses the delivery air;it is connected across terminals 51 - 53 and send a visual and an audible alarm. This smoke sensor is not intended to function as, or replace, any room smoke detection system that may be required by local or national codes. 1 AMP, 24VAC max load. Use Class 1 field supplied wiring.
12. Condensate alarm (with condensate pump option) : On pump high water indication, Normally open dry contact is connected to a purple wire installed inside of the box near the pump. This contact is closed in case of a high water indication thus remote High Water indication is provided. 1AMP, 24Vac max load; use class 1 field supplied wiring.

OPTIONAL LOW VOLTAGE TERMINAL PACKAGE CONNECTIONS

13. Flooding alarm (liquistat) – The flooding alarm detects the presence of water and activate an alarm. The sensor is connect across terminals 105 & 106 and up to 5 sensors can be connected to the same flooding alarm device,to control many points in the bottom of the unit.

10

Refrigeration & Hydraulic Circuits

Fig. 10a Liebert CR011RA - CR021RA

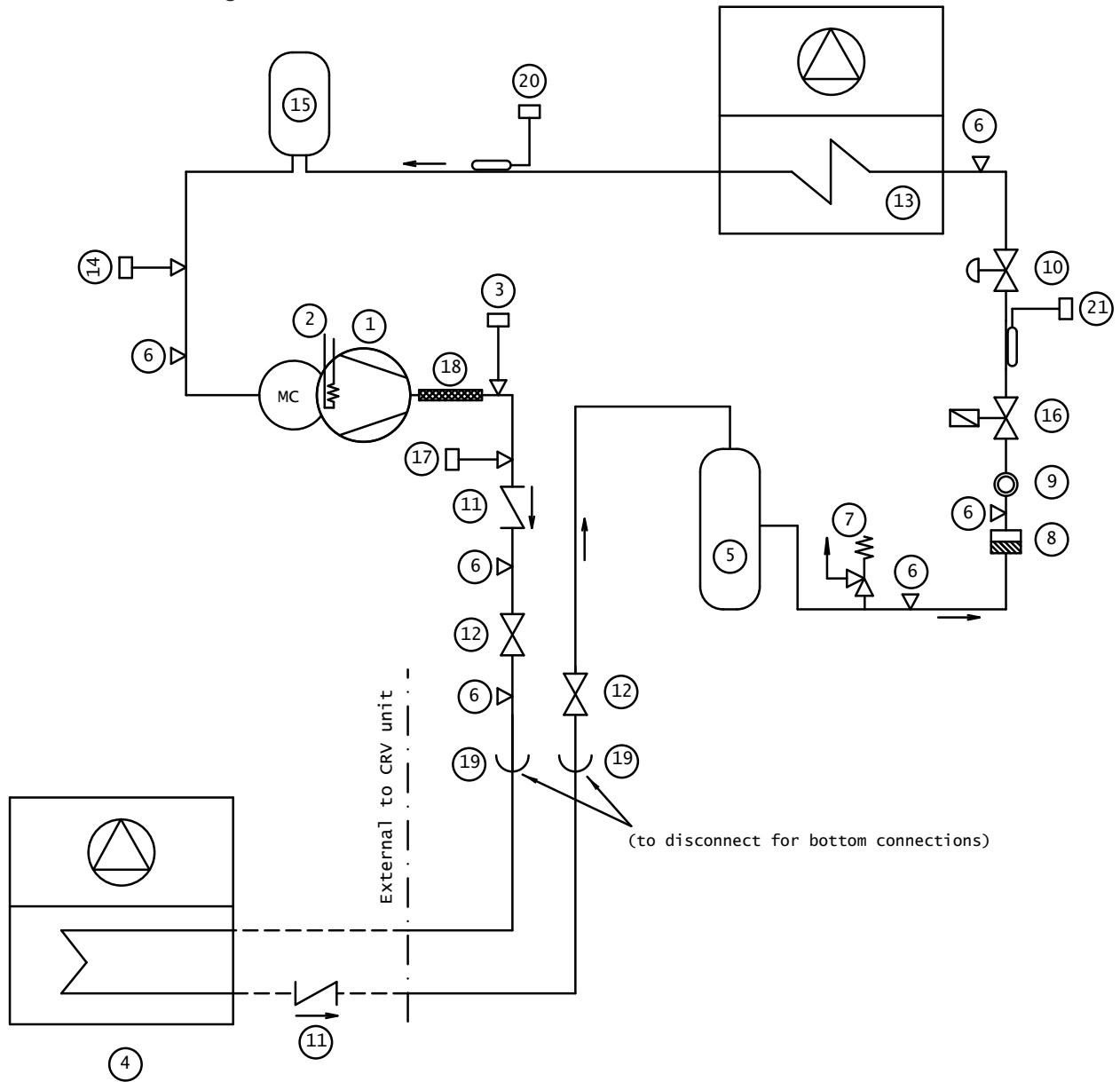

POS.	DESCRIPTION	POS.	DESCRIPTION
1	COMPRESSOR	12	SHUT-OFF VALVE
2	CRANKCASE HEATER	13	EVAPORATING COIL
3	HIGH PRESSURE SWITCH	14	LOW PRESSURE TRANSDUCER
4	AIR COOLED CONDENSER	15	LIQUID SEPARATOR
5	LIQUID RECEIVER	16	SHUT-OFF SOLENOID VALVE
6	ACCESS VALVE 5/16"	17	HIGH PRESSURE TRANSDUCER
7	SAFETY RELIEF VALVE	18	VIBRATION ABSORBER
8	FILTER DRYER	19	CUP AND FITTING (SWEAT) JOINT
9	SIGHT GLASS	20	TEMPERATURE SENSOR FOR EEV
10	ELECTRONIC THERMOSTATIC EXPANSION VALVE	21	LIQUID TEMPERATURE SENSOR
11	CHECK VALVE		

Refrigeration & Hydraulic Circuits

Fig. 10b Liebert CR032RC - CR060RC

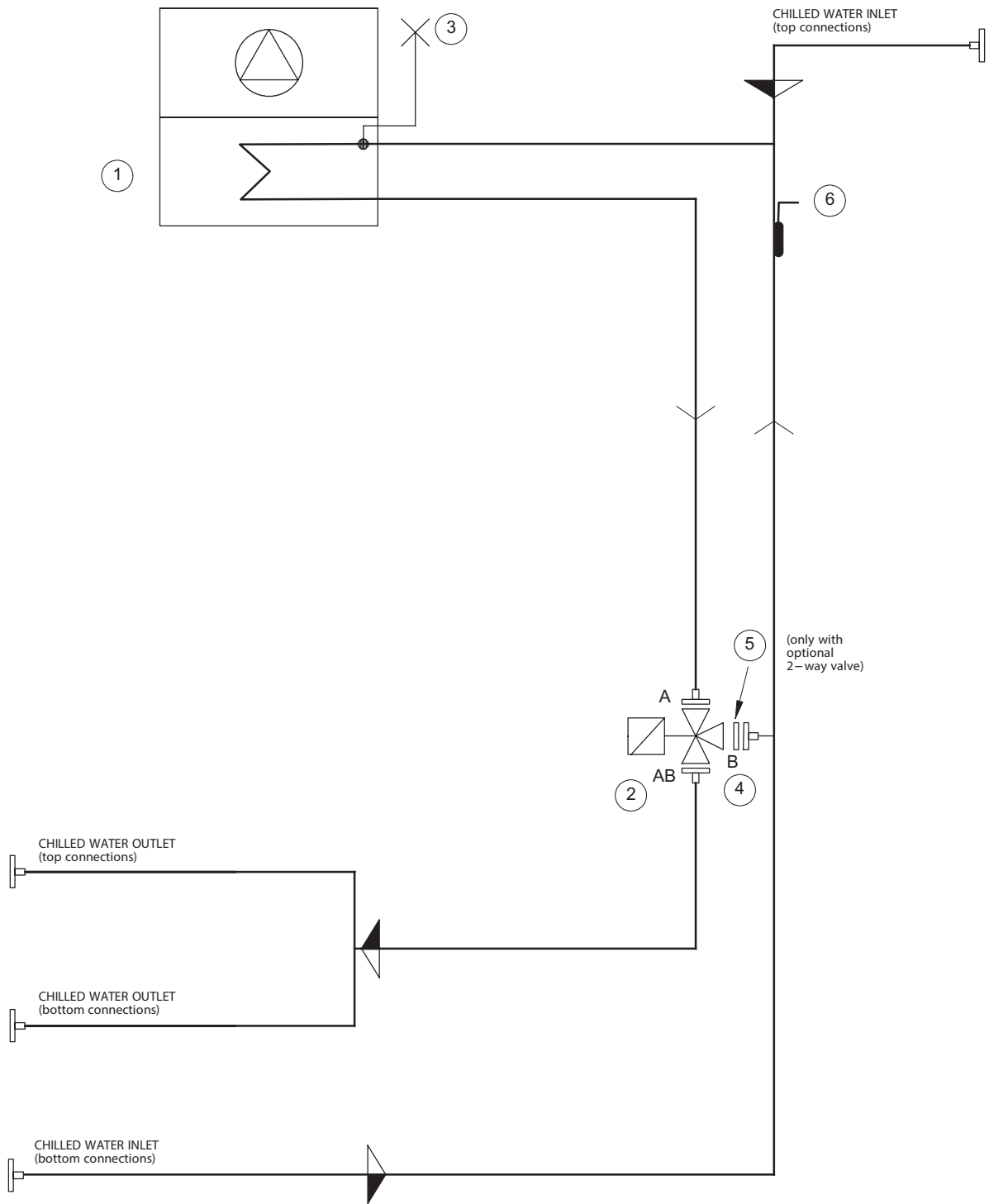

POS.	DESCRIPTION
1	Chilled water cooling coil
2	3 - port water valve
3	Air bleeding valve
4	Valve fittings
5	Blind disk - only with optional 2 - way valve
6	NTC inlet water sensor



VERTIV™

Fabbricante - Manufacturer - Hersteller - Fabricant - Fabricante
Fabricante - Tillverkare - Fabrikant - Valmistaja - Produzent
Fabrikant - Κατασκευαστής - Producent
Vertiv S.r.l. - Zona Industriale Tognana
Via Leonardo da Vinci, 16/18 - 35028 Piove di Sacco - Padova (Italy)

Il Fabbricante dichiara che questo prodotto è conforme alle direttive Europee:
The Manufacturer hereby declares that this product conforms to the European Union directives:
Der Hersteller erklärt hiermit, dass dieses Produkt den Anforderungen der Europäischen Richtlinien gerecht wird:
Le Fabricant déclare que ce produit est conforme aux directives Européennes:
El Fabricante declara que este producto es conforme a las directivas Europeas:
O Fabricante declara que este produto está em conformidade com as directivas Europeias:
Tillverkare försäkrar härmed att denna produkt överensstämmer med Europeiska Unionens direktiv:
De Fabrikant verklaart dat dit produkt conform de Europese richtlijnen is:
Valmistaja vakuuttaa täten, että tämä tuote täyttää seuraavien EU-direktiivien vaatimukset:
Produzent erklærer herved at dette produktet er i samsvar med EU-direktiver:
Fabrikant erklærer herved, at dette produkt opfylder kravene i EU direktiverne:
Ο Κατασκευαστής δηλώνει ότι το προϊόν πληροί να είναι κατασκευασμένο σύμφωνα με τις οδηγίες της Ε.Ε.:

2006/42/EC; 2014/30/EU; 2014/35/EU; 2014/68/EU



VertivCo.com | Vertiv - EMEA, via Leonardo Da Vinci 16/18, Zona Industriale Tognana, 35028 Piove di Sacco (PD) Italy, Tel: +39 049 9719 111, Fax: +39 049 5841 257

© 2016 Vertiv Co. All rights reserved. Vertiv, the Vertiv logo and Vertiv Liebert CRV300 are trademarks or registered trademarks of Vertiv Co. All other names and logos referred to are trade names, trademarks or registered trademarks of their respective owners. While every precaution has been taken to ensure accuracy and completeness herein, Vertiv Co. assumes no responsibility, and disclaims all liability, for damages resulting from use of this information or for any errors or omissions. Specifications are subject to change without notice.