



**INSTALLATION, OPERATION AND  
MAINTENANCE INSTRUCTIONS**



## Ductable Comfort Units

42NH - CLZ

Heating capacity: 1 to 12 kW  
Cooling capacity: 0,6 to 9 kW

The illustrations in this document are for illustrative purposes only and not part of any offer for sale or contract. The manufacturer reserves the right to change the design at any time without notice.

# CONTENTS

---

<b>1 - UNPACKING, CHECKING AND STORING THE UNIT .....</b>	<b>15</b>
<b>2 - HANDLING .....</b>	<b>15</b>
<b>3 - DESCRIPTION OF THE UNIT (FIG. 1).....</b>	<b>16</b>
3.1 - Name plate (Fig. 2).....	16
3.2 - Models.....	17
3.3 - Dimensions and weight .....	17
<b>4 - INSTALLATION AND CONNECTIONS .....</b>	<b>18</b>
4.1 - Mechanical connections .....	18
4.2 - Air connections .....	18
4.3 - Hydraulic connections .....	18
4.4 - Condensate pump draining connection.....	20
4.5 - Connecting the condensate drain pump (option) .....	20
4.6 - Electrical connections.....	21
<b>5 - SERVICING AND MAINTENANCE .....</b>	<b>24</b>
5.1 - Air filter .....	24
5.2 - Condensate drain pan .....	24
5.3 - Fan motor assembly.....	25
5.4 - Heat exchange coil.....	25
<b>6 - REGULATIONS .....</b>	<b>26</b>
<b>7 - TESTING &amp; WARRANTY .....</b>	<b>27</b>

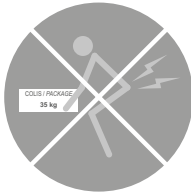
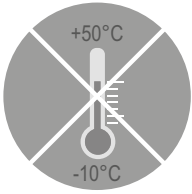
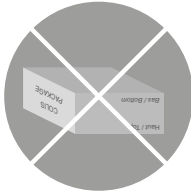


Fig. 1

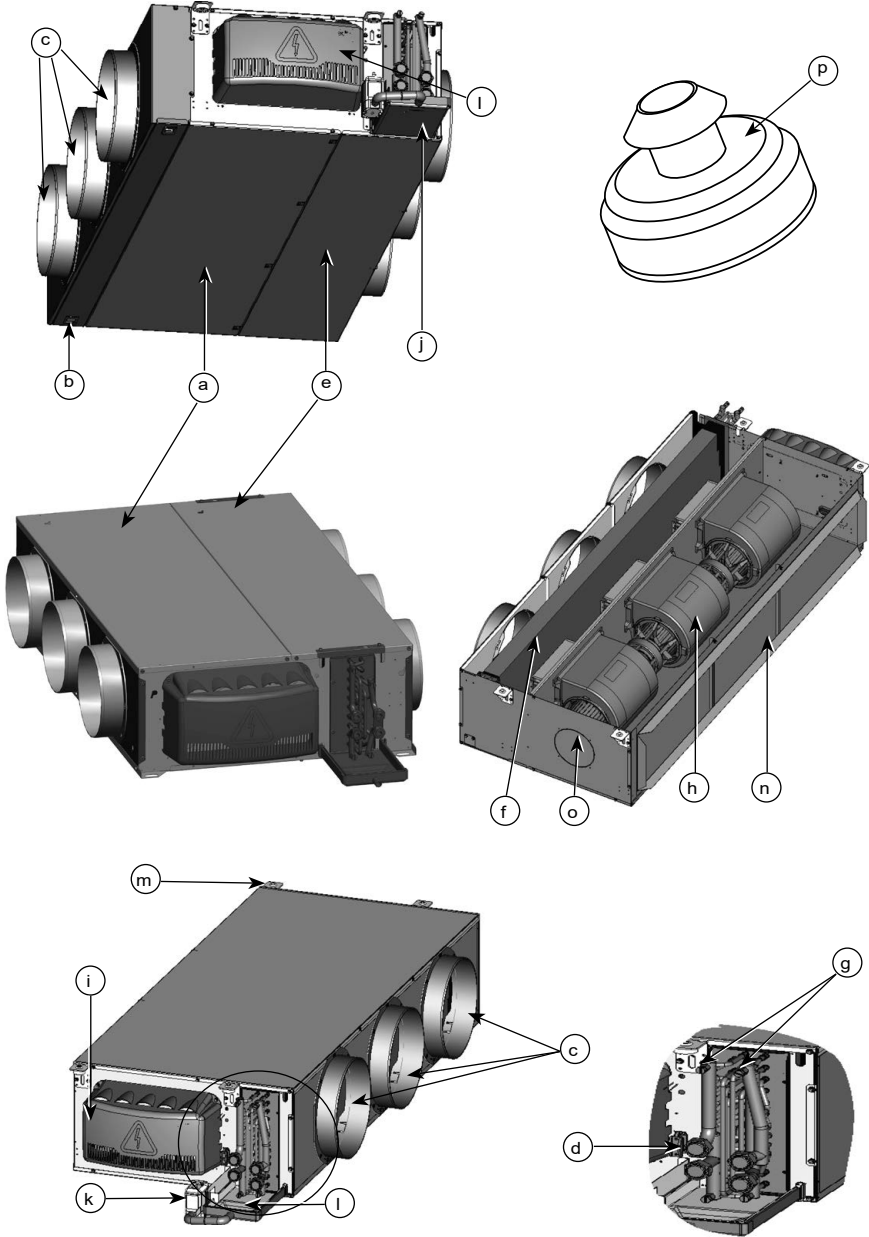
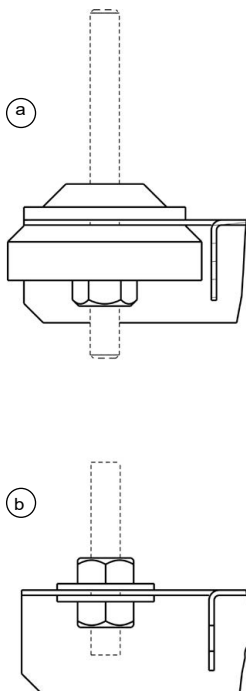


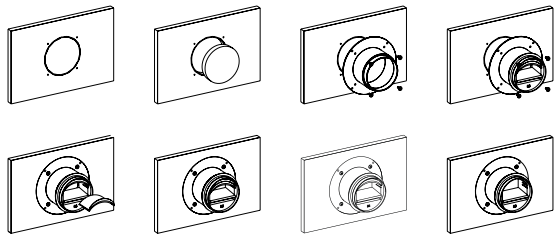
Fig. 2

Ref. produit/Item Ref.		Designation/Description	
7412910.430615		42NH239FEG-A-A	
An/Year	N° série/Serial Nbr	Composants/Components	Repère/Part
2020	02461545/0001	IOM : 42NH - CLZ	~
Moteur/Motor (Ph/Hz/V)	Batterie/Hydro. coil	Fluide/Fluid	
1+N 50/60HZ 230V/220V+T	2T21	EAU	
P. moteur/Motor P. (W) - I. (A)	Elec Element (Ph/Hz/V)	Maxi pressure	
195 W / 245W max   1.5A / 1.8A	SAN\$	1600000 PA (16BAR)	
tr. mn - 1/r.p.m.	Elec Element P. (W)/I.(A)	Cablage/Wiring	
1150 / 1500 / 1600	SAN\$	5V/7,7V/9V	
Masse/Weight en service kg	Elec Diagram	N° Declaration CE	
66	7582176	7606409.00	

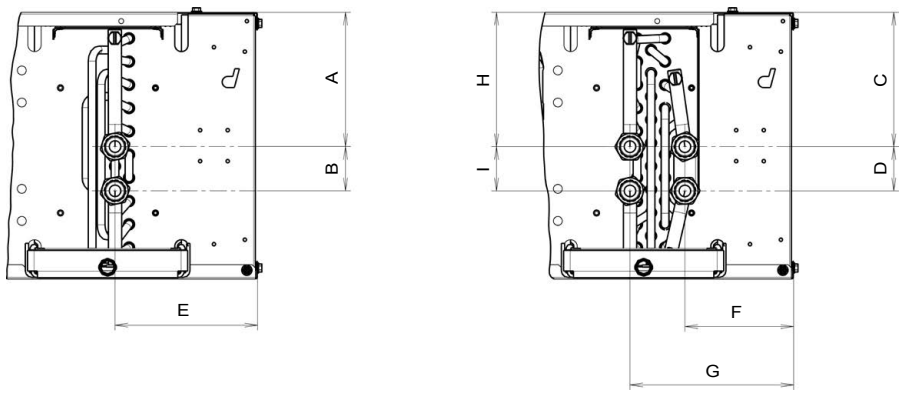
Fig. 3



**Fig. 4**

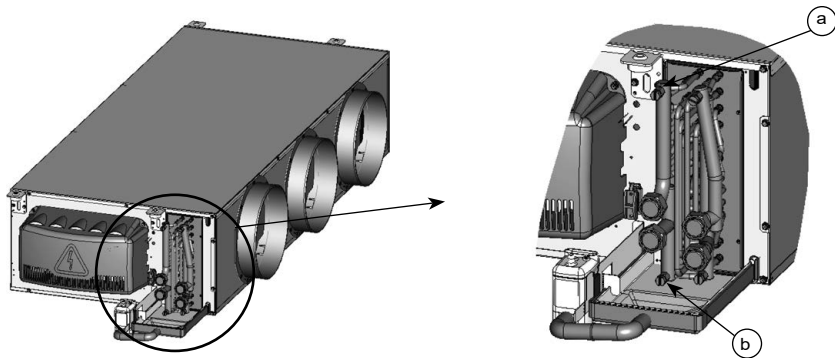


**Fig. 5**

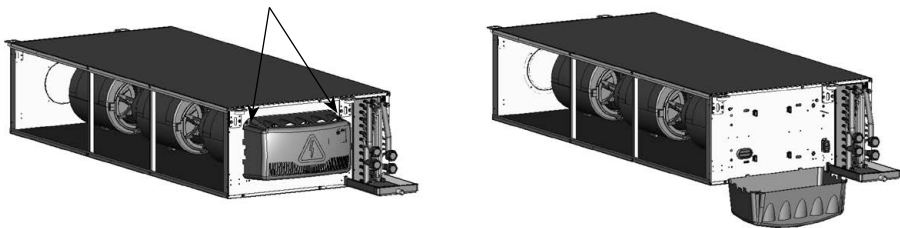


SIZES	A	B	C	D	E	F	G	H	I
<b>T2</b>	121	40	121	40	129	98	148	121	40
<b>T3</b>	121	40	121	40	129	98	148	121	40
<b>T4</b>	121	40	121	40	129	98	148	121	40
<b>T5</b>	121	40	121	40	129	98	148	121	40
<b>T6</b>	129	40	175	40	83,5	55,5	111,6	158	40
<b>T7</b>	129	40	175	40	83,5	55,5	111,6	158	40

**Fig. 6**



**Fig. 7**



**Fig. 8**

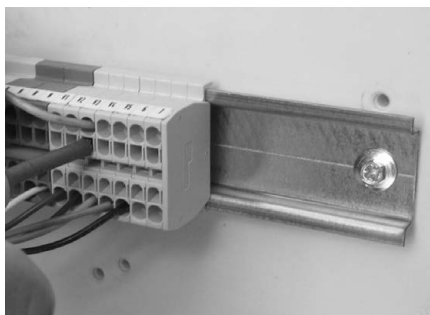




Fig. 9

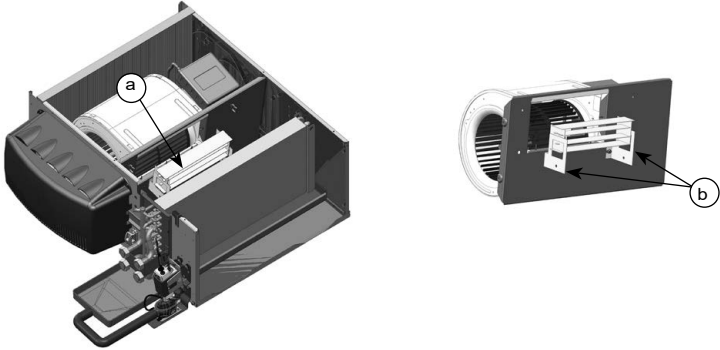


Fig. 10

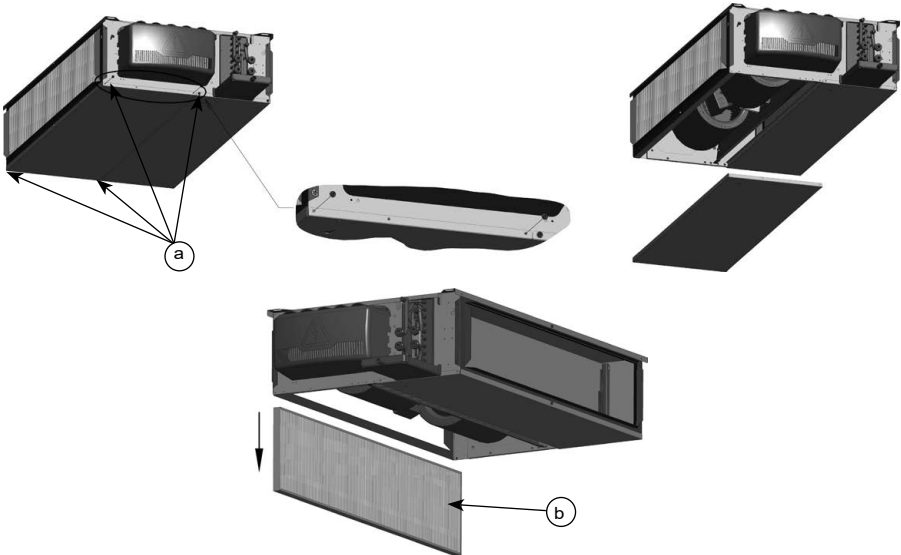


Fig. 11

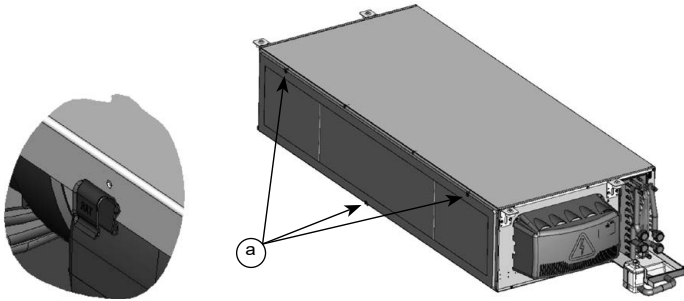


Fig. 12

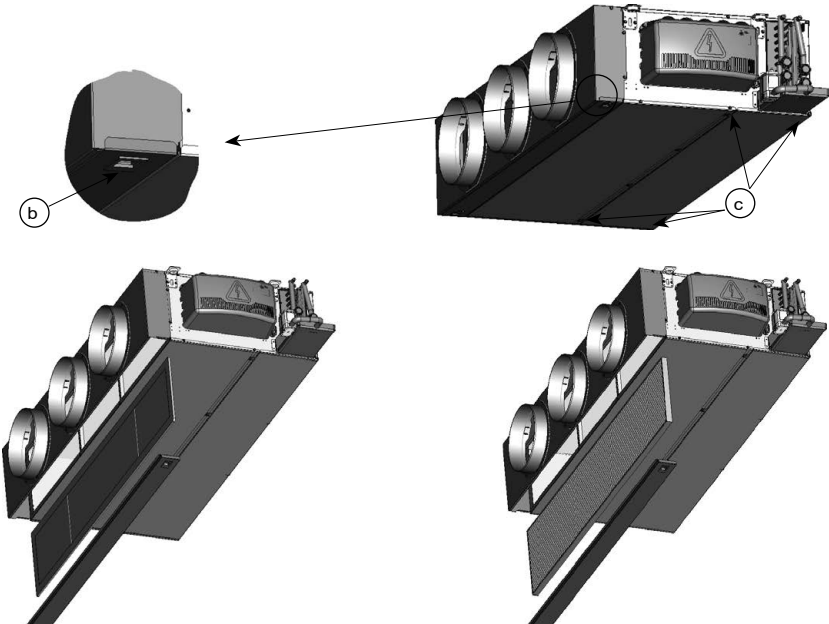


Fig. 13

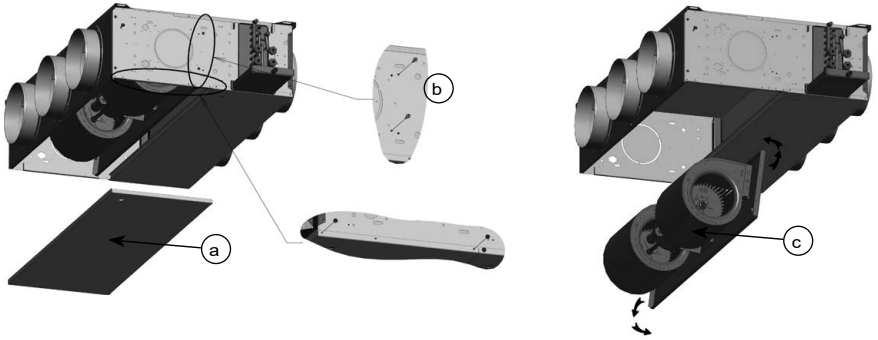


Fig. 14

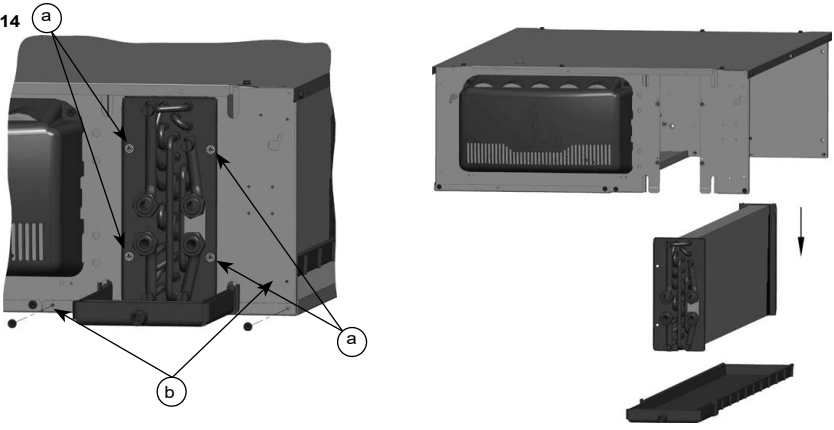
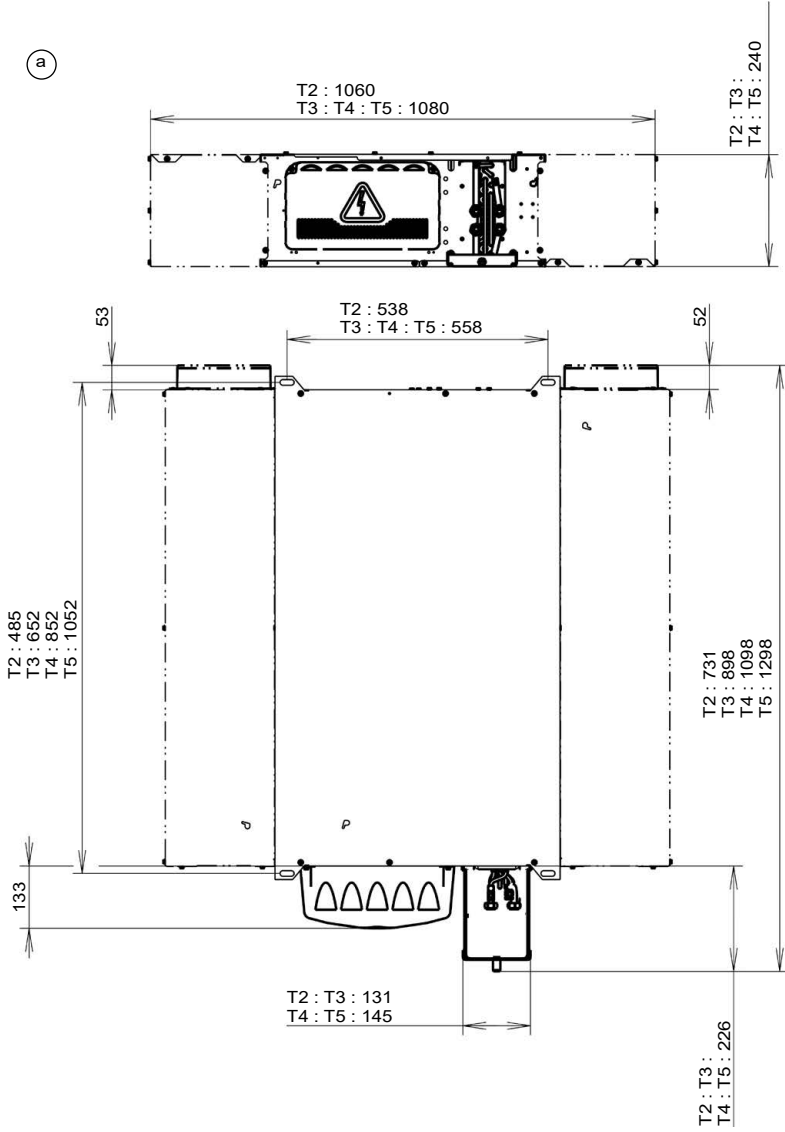
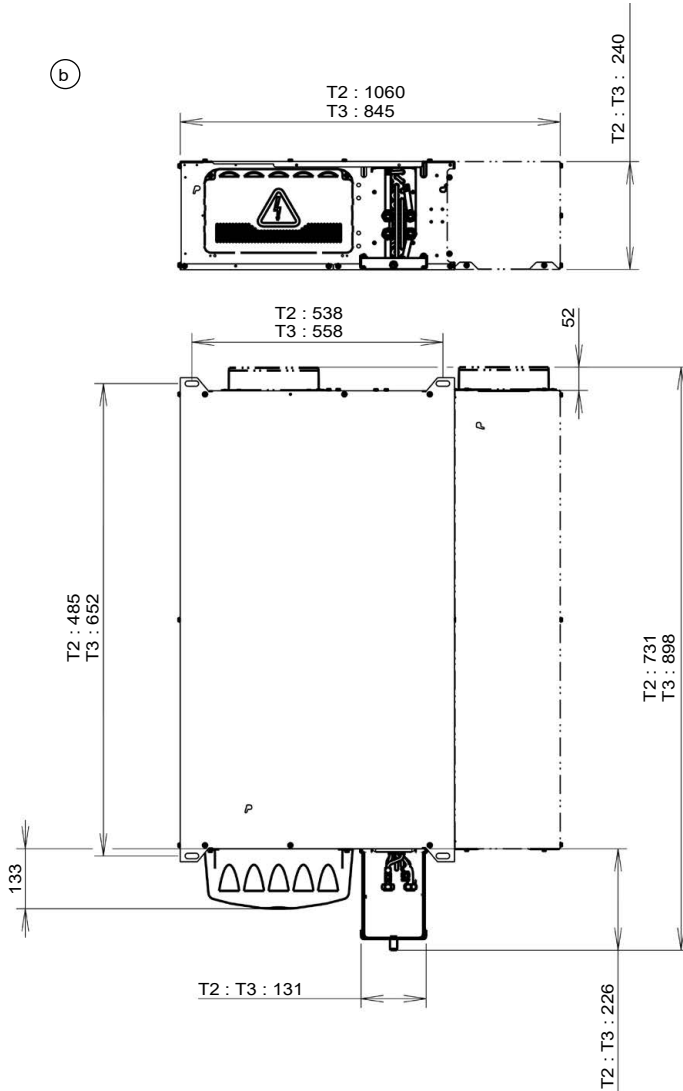


Fig. 15

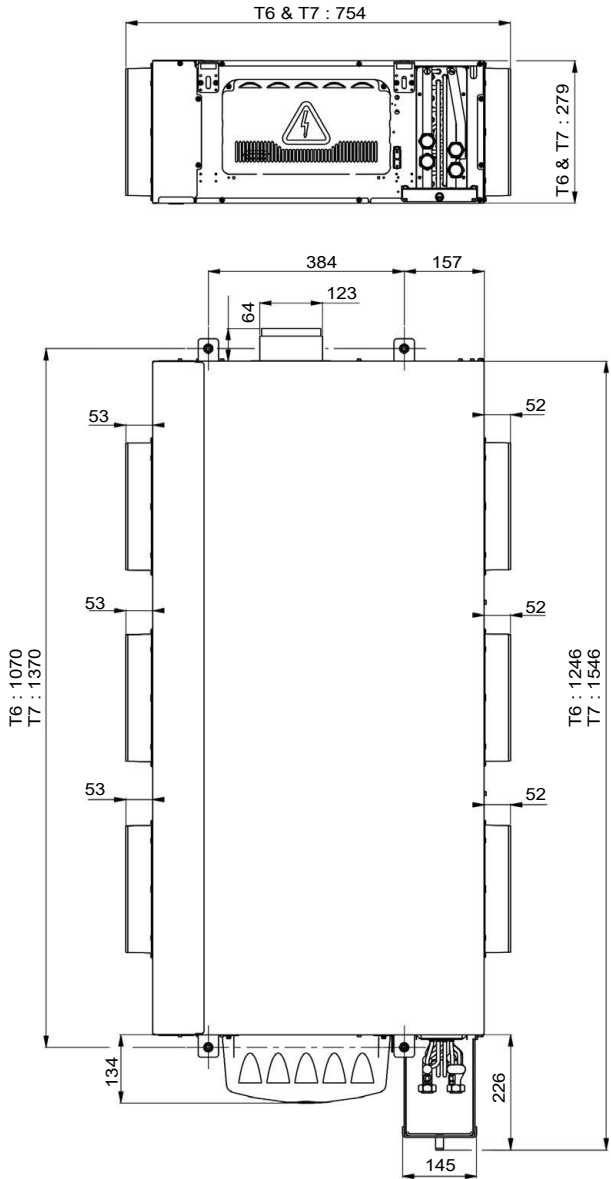


(b)



42NH	Weight			
	T2	T3	T4	T5
U Standard	20,5	25,5	26,1	35,1
U Compact (without filter)	17,5	21,5	-	-

©



42NH	Weight	
	T6	T7
Base unit only	29	35
Base unit + supply plenum	30,5	37
Base unit + supply plenums + linear return	34	41

# 1 - UNPACKING, CHECKING AND STORING THE UNIT

---

Thank you for purchasing a CARRIER unit. We trust that this unit will give you complete satisfaction.

To ensure correct operation, all connections (electrical, hydraulic, etc.) must be made in accordance with best industry practice and the regulations in force in the country of installation.

Your unit must be maintained and installed as recommended in this manual.

Each device bears a name plate. The reference number shown on the name plate must be quoted in all correspondence.

**It is the recipient's duty to inspect the contents of the packages upon receipt:**

- In the event of missing items, the customer must provide the exact number of parcels delivered.
- If any damage is found on delivery, report it on the delivery receipt in the presence of the delivery driver before the delivery note is signed.

***IMPORTANT: in accordance with Article 133 of the French Code of Commerce, these claims must be reported to the carrier by registered letter within three business days of receipt. The terms "conditional" and "pending unwrapping" shall have no value. The client must unwrap the goods in the presence of the driver. Claims must be made at the time of delivery and be described in detail.***

# 2 - HANDLING

---



**For your safety, wear protective gloves**

***Important: the unit must be handled with care and kept flat. Impacts may cause damage to the frame or the body of the unit and adversely affect its main functions and its appearance.***

The unit should preferably be lifted by its mounting holes (Fig. 1, m) and **never** by the condensate pan or the collars. It is possible to carry out the installation using a fork-lift truck, as long as care is taken not to damage the unit.

The unit is placed inside the suspended ceiling. If the return has no duct, ensure that the rear of the unit is at a sufficient distance from the wall (X = min. 250 mm).

### 3 - DESCRIPTION OF THE UNIT (FIG. 1)

---

- |   |  |
|---|--|
| a - Fan motor assembly access panel and filter              | i - Electrics box  |
| b - Filter runner for assembly with return sleeve or plenum | j - Condensate drain pan   |
| c - Spigots   | k - Condensate drain pump  |
| d - Header couplings  | l - Condensate drainage  |
| e - Coil lower access panel                                 | m - Trou de fixation   |
| f - Exchanger coil  | n - Air filter   |
| g - Air bleed and drain valves                              | o - Pre-punched fresh air inlet (opposite side to electrics box) |
| h - Fan motor assembly                                      | p - Resilient mount  |

#### 3.1 - Name plate (Fig. 2)

The name plate contains all the information required to identify the unit and its configuration. This plate is placed on the technical side that has all the connections, above the fresh air inlet.

Before contacting us, please note the serial no. and the designation.

- |                                     |  |
|-------------------------------------|--|
| ① Code                              | ⑦ Wiring diagram reference                   |
| ② Serial number                     | ⑧ Motor speed wiring                         |
| ③ Unit designation                  | ⑨ Maximum operating pressure                 |
| ④ Maximum/nominal current and power | ⑩ Electric heater specifications (if fitted) |
| ⑤ Motor rotation speed              | ⑪ EC declaration number                      |
| ⑥ Coil type                         |  |

**Important:**

***This device may be used by children aged eight and over, and by persons with limited physical, sensory or mental capabilities, or by persons with insufficient experience or knowledge, provided that they are being correctly supervised or provided they have received instructions on how to use the device in complete safety, ensuring that they have a full understanding of any risks involved. Children must not play with the unit. User cleaning and maintenance must not be performed by children.***

***The 42NH range of fan coil units is used to heat or cool premises in the tertiary sector. 42NH can be ducted to the suction and on the supply air.***

***During normal use, this unit is intended to operate under the following conditions:***

- ***Maximum altitude: 2000 m,***
- ***Minimum and maximum storage temperatures: -20 °C/+65 °C,***
- ***Minimum and maximum operating temperatures: 0 °C/+ 40 °C,***
- ***Indoor return air maximum humidity level: 27°C DB (dry bulb) at 65% RH (Relative Humidity),***
- ***Clean interior environment (no corrosive substances present).***

***The device is designed for indoor use, and requires protection from any form of impact. Protection rating IP 20 IK02.***

***This device is designed to operate in an over-voltage category II and pollution degree 2 environment, in accordance with IEC standard 664-1.***

***To ensure a pollution degree 2 environment, the device must be protected from water and oil splashes, and the dust allowed to settle on it must be limited.***



## **3 - DESCRIPTION OF THE UNIT (FIG. 1)**

---

### **3.2 - Models**

The 42NH is available in 4 standard models:

Base unit only : Metal sleeve on the discharge (optional) and optional metal sleeve on the intake

Base unit + supply plenum : Supply plenum with collars for round ducts + metal sleeve optional on intake

Base unit + supply plenums + linear return : Return and supply plenum with collars for round ducts

U : Return and supply plenum with lateral collar for round ducts.

### **3.3 - Dimensions and weight**

- Dimensions and weight, see Fig. 15.

## 4 - INSTALLATION AND CONNECTIONS

---



To prevent injury or damage to the unit or room, work must only be carried out by qualified personnel.

### 4.1 - Mechanical connections

Prior to installation, check that there will be sufficient space to allow maintenance and servicing work to be performed.

The 42NH must be secured to the ceiling or floor using 4 threaded rods either 6 mm or 8 mm in diameter (not supplied), which are fixed to the unit's 4 mounting systems using anti-vibration resilient mounts (fig. 3, a) or a nut/washer assembly positioned on either side of the mounting bracket (fig. 3, b).

**Note:** CARRIER strongly recommends the use of anti-vibration resilient mounts when securing the unit, in order to reduce the transmission of vibrations through the building structure during operation.

**Warning:**

- The unit must be perfectly level in relation to the suspended ceiling to prevent condensate draining problems (see procedure for removing the condensate pan)
- If a room thermostat is fitted, place it on an inside wall (not behind a door) and at a height of 1.50 m from the floor. Keep it away from sunlight and all sources of heat.

### 4.2 - Air connections

#### ■ Air quality

Comfort units are not designed to control the humidity of outside air. Fresh air handling must be provided by an independent system in accordance with accepted engineering practice (see air handling unit ranges).

**Warning:** all collars must be connected, whatever the model. None must be capped, either for the supply or return air.

#### ■ Fresh air knockout

If the fresh air return leads directly outside, the duct must not exceed 5 metres in length. The fresh air temperature must not be below -10 °C. A rain guard grille and a filter must be fitted (at the installer's expense) to prevent water or other material entering the duct from outside. If an auxiliary fan is being used (supplied by the installer), the flow of fresh air must be limited to 10% of the unit's nominal flow rate to prevent noise, coil frosting or air filter bypass problems.

#### ■ Adjusting the fresh air collars (Fig. 4):

Either remove or leave on the shims needed to obtain the desired flow rate. The flow rate ranges are given on the label on the casing. 2 shims for minimum flow, 1 shim for medium flow, no shims for maximum flow.

The pressure difference must be between 50 and 100 Pa in order to obtain the desired flow rate.

Maintain the controller in the "BAS" (down) position.

### 4.3 - Hydraulic connections

Water always flows into the bottom of the coil and exits at the top. For 4-tube coils, please respect the instructions given on the labels affixed to the coil.

The pipe system is positioned according to fig. 5.

The coils are equipped (fig. 6) with flat face swivel nuts with a female thread, diameter G ½" or G ¾" depending on the size of the unit, and an O-ring (supplied by CARRIER).

The manifold is equipped with an air bleed valve (fig. 6, a), at the high point with partial draining at the low points (fig. 6, b) that can be manoeuvred using a 7 mm Allen key or a flat-blade screwdriver.

**IMPORTANT:** The coil can be partially drained, however precautions must be taken during winter if the installation is shut down. To drain completely, air must be blown through the circuit.

Once the hydraulic connections are completed, it is not necessary to insulate the valves to prevent condensation (unless specifically required for the particular valves). A naturally inclined pan extension may be supplied with the unit as an option. This recovers condensate from the valves and drains it via gravity or using a condensate drain pump (supplied as an option).

## 4 - INSTALLATION AND CONNECTIONS

---

### ■ Installation

CARRIER does not guarantee the tightness of coil couplings equipped with O-rings for a tightening torque of over 18 N.m.

During connection, always use a holding wrench on the component being connected to ensure the manifold is not twisted.

### ■ Design

The installation of the hydraulic system is crucial to the correct operation of the system. Drain valves should therefore be placed at the appropriate points and in sufficient number. In addition, strainers should be fitted, as well as vents at circuit high points, balancing tees and shut-off valves on each coil and, if necessary, pressure relief valves.

### ■ Filtration:

An efficient filtration system (recommended mesh size of 0.5 mm) should be fitted on the supply water and return water lines.

### ■ Flushing:

The system must be flushed completely and filled with treated water to prevent the build-up of scale or sludge in the circuit. When flushing the circuit, **open the valve on the unit** to prevent any sludge or impurities from building up in the coil.

### ■ Filling

Purge the coils during system start-up.

### ■ Water quality recommended for water coils

It is recommended to carry out a bacteriological analysis (detection of ferrobacteria, bacteria producing H<sub>2</sub>S and reducing sulfates) and a chemical analysis (to avoid problems with scaling and corrosion) of the water.

- Total hardness (French scale) 10 < TH < 15
- Chloride [CL<sup>-</sup>] < 10 mg/l
- Sulfate [SO<sub>4</sub><sup>2-</sup>] < 30 mg/l
- Nitrate [NO<sub>3</sub><sup>-</sup>] = 0 mg/l
- Dissolved iron < 0.5 mg/l
- Dissolved oxygen 4 < [O<sub>2</sub>] < 9 mg/l
- Carbon dioxide [CO<sub>2</sub>] < 30 mg/l
- Resistivity 2000 < Resistivity < 5000 Ωcm
- pH 6.9 < pH < 8

### ■ Operating limit recommendations:

Cooling coil inlet minimum water temperature: **5°C**

Heating coil inlet maximum water temperature (2-tube application without electric heaters): **70°C**

Heating coil inlet maximum water temperature (2-tube application with electric heaters operating simultaneously): **55°C**

Heating coil inlet maximum water temperature (4-tube application): 90°C

Maximum operating pressure: **16 bar**

Indoor return air min./max. temperature: **+0°C/+40°C**

Indoor return air maximum humidity level: **27°C DB** (dry bulb) at **65% RH** (Relative Humidity).

### ■ Operating recommendations:

For control valves equipped with electrothermal motors, the temperature of the air surrounding the thermo-actuators should not exceed 50°C. This is especially important for units installed in confined spaces (e.g. in suspended ceilings).

CARRIER shall not be liable for damage to valves caused by faulty design of the hydraulic supply network or incorrect commissioning.
--

## 4 - INSTALLATION AND CONNECTIONS

### 4.4 - Condensate pump draining connection

Use a flexible and/or rigid drain pipe for a minimum slope of 1 cm/m, with a constant gradient along its whole length and no low points.

Install a siphon measuring at least 5 cm to prevent any discharge of unpleasant gases or odours.

### 4.5 - Connecting the condensate drain pump (option)

As an option, the condensate drain pump can be supplied connected but not mounted on the unit  
Its technical specifications are as follows:

For sizes 2 to 5:

- Maximum flow of 8.5 l/h for a pumping height of 2 metres and a horizontal pipe length of 5 metres.
- Maximum flow of 7 l/h for a pumping height of 4 metres and a horizontal pipe length of 5 metres.

The operation points are provided in the table below.

Connect a clear drain pipe (not supplied) with an internal diameter of 6 mm between the pump outlet and the wastewater pipe. This pipe should not be pinched or touch the unit or any other external component.

Table of actual flow rates for the pump connected to a PVC pipe with an internal diameter of 6 mm.

Pump performance: Water flow rate in litres per hour (-15% / +20%)				
Discharge height	Horizontal length of the discharge pipe			
	5 metres	10 metres	20 metres	30 metres
1 metre	10,4	9,1	8,3	7,3
2 metres	8,5	7,8	7	6,4
3 metres	7,9	7,1	6,3	5,8
4 metres	7	6	5,3	4,9

For sizes 6 and 7:

- Maximum flow of 16 l/h for a head height of 2 metres and a maximum pipe length of 5 metres.
- Maximum flow of 15 l/h for a head height of 2 metres and a maximum pipe length of 10 metres.

The operation points are provided in the table below. Connect a clear drain pipe (not supplied) with an internal diameter of 6 mm between the pump outlet and the wastewater pipe. This pipe should not be pinched or touch the unit or any other external component.

Table of actual flow rates for the pump connected to a PVC pipe with an internal diameter of 6 mm.

Pump performance: Water flow rate in litres per hour				
Discharge height	Total length of the discharge pipe			
	5 metres	10 metres	20 metres	30 metres
0 metre	20	19	18	17
2 metres	16	15	14	13,5
4 metres	11,5	11	10,5	10
6 metres	-	8,5	7,5	6,5
8 metres	-	6	5	4
10 metres	-	4	3,5	2,5

Under operating conditions outside of the temperature and relative humidity ranges recommended in the "Operating limit recommendations" section, the discharge pipe must be insulated to prevent the formation of condensation, which could damage the installation and the pump. We recommend using a flexible transparent PVC type pipe with internal diameter 6 mm/external diameter 9 mm. It is essential to ensure that the pump connections are sealed. A clamp can be used for this purpose.

**Warning:** Make sure that the flow of water to be discharged in the thermal selection is suitable for your application.

**Note:** this accessory must always be used with a valve control device, to ensure valve control of the high safety device when the valve is closed (closure of the condensate drains).

## 4 - INSTALLATION AND CONNECTIONS

### 4.6 - Electrical connections



- Disconnect the electrical supply to the unit before carrying out any work and wait at least 20 mins before working on or near the heating elements. Beware of the risk of burns.

Only personnel qualified to work on electrical connections may carry out installation and maintenance work. Before connecting the unit to the network, ensure that the voltage matches that indicated on the name plate.

42NH	Motor reference	AC Asynchronous Motor					
		T2	T3	T4	T5	T6	T7
Max power input (W)	V5 (R1)	71	107	130	150	360	398
	V4 (R2)	48	87	123	134	330	373
	V3 (R3)	34	70	116	118	292	320
	V2 (R4)	21	41	105	109	245	249
	V1 (R5)	14	18	97	98	203	198
Max current draw (A)	V5 (R1)	0,31	0,45	0,51	0,62	1,47	1,77
	V4 (R2)	0,20	0,37	0,48	0,56	1,33	1,66
	V3 (R3)	0,15	0,30	0,46	0,51	1,21	1,37
	V2 (R4)	0,09	0,18	0,43	0,46	1,06	1,07
	V1 (R5)	0,07	0,08	0,41	0,42	0,91	0,87

42NH	Control voltage (Volts)	EC Brushless Motor					
		T2	T3	T4	T5	T6	T7
Max power input (W)	2	4	4	6	5	6	15
	3	6	8	10	12	13	36
	4	9	12	14	18	21	58
	5	14	23	25	33	40	98
	6	19	33	36	48	59	138
	7	29	54	62	83	101	192
	8	42	75	89	117	143	245
	9	60	109	127	141	147	246
	10	66	143	166	165	152	246
	Max current draw (A)	2	0,04	0,05	0,05	0,05	0,06
3		0,06	0,07	0,08	0,09	0,10	0,24
4		0,08	0,09	0,10	0,13	0,15	0,37
5		0,11	0,16	0,17	0,22	0,26	0,61
6		0,15	0,22	0,23	0,31	0,37	0,85
7		0,23	0,34	0,39	0,51	0,60	1,17
8		0,32	0,47	0,54	0,72	0,84	1,50
10		0,49	0,87	1,00	1,00	0,89	1,50

## 4 - INSTALLATION AND CONNECTIONS

An earth connection is compulsory. CARRIER shall not be liable for incidents resulting from faulty or non-existent earthing. Always follow the wiring diagram delivered with unit.

### To access the electrical terminal block:

#### Disconnect the unit from the electrical power supply

Use a Phillips screwdriver or a size 7 Allen key to undo the 2 screws securing the electrics box cover (Fig. 7).

For the terminal strip, always use an electrician's flat-blade screwdriver.

42NH offers a choice between two types of motor technology: asynchronous and brushless (low consumption).

#### ■ The asynchronous motor:

To optimise the unit's performance and depending on the type of control used, the unit has five speeds numbered V1(R5) to V5(R1) connected to the terminal block in the electrics box (V1(R5) = low speed and V5(R1) = high speed).

The customer must wire the speeds for the thermostat at the top of the terminal block between V1(R5) to V5(R1).

To open a connection point and change the cabling (Fig. 8):

- Place the end of a flat-blade screwdriver in the hole located just below the cable to be removed, release the cable and move it to the marker for the desired speed.
- Place the screwdriver in the hole again just below the desired speed, insert the cable and remove the screwdriver; this ensures a secure contact.

Repeat the procedure for the remaining customer speeds.

**IMPORTANT: the wires coming from the motor and connected to terminals V1(R5) to V5(R1) must never be interconnected.**

**IMPORTANT: it is essential to refit the electrical box casing once all the cabling and adjustment operations are complete.**

#### ■ The brushless motor:

Depending on the controller or thermostat fitted with the unit, the motor may be controlled by a 0-10V control signal.

- With a controller managing a 0-10 V control signal:

The 0-10V setpoint voltage information is issued by the controller itself. Refer to the operating and configuration instructions supplied by the manufacturer.



**Warning: To prevent any risk of damage, never connect several asynchronous or brushless fan coil unit motors in parallel for the same thermostat.**

#### **IMPORTANT NOTE: Brushless motor**

**The electrical connection for 42NH must be made in compliance with international standard IEC 60364 (Electrical Installations for Buildings).**

**The leakage current on all our comfort units conforms to the requirements of IEC 60335-2-40 (Safety of household and similar electrical appliances):**

- **Complete comfort unit (with electric heaters) equipped with a multi-speed motor: maximum leakage current = 2 mA**
- **Complete comfort unit (with electric heaters) equipped with an HEE motor (brushless technology): maximum leakage current = 4.5 mA.**

**Electromagnetic compatibility in accordance with Emission standard 61000-6-3 EN 550141-1, tool class and Immunity 61000-6-1 (Residential, commercial and light industry class).**

## 4 - INSTALLATION AND CONNECTIONS

**Important:** The unit's compliance with the above standards does not guarantee the compliance of the installation as a whole (several other factors not relating to the unit may be involved). As a result, the installer must observe the applicable recommendations in order to guarantee compliance.



General safety instructions for units with electric elements:

Connecting 42NH to an air flow circuit alters its performance. The user must ensure that the minimum air flow rates indicated below are respected:

	AC Motor	Brushless Motor
<b>Size 2</b>	170 m <sup>3</sup> /h (Speed 2 <sup>(1)</sup> )	170 m <sup>3</sup> /h (3,5 volts <sup>(1)</sup> )
<b>Size 3</b>	170 m <sup>3</sup> /h (Speed 2 <sup>(1)</sup> )	170 m <sup>3</sup> /h (3,5 volts <sup>(1)</sup> )
<b>Size 4</b>	170 m <sup>3</sup> /h (Speed 1 <sup>(1)</sup> )	170 m <sup>3</sup> /h (3,5 volts <sup>(1)</sup> )
<b>Size 5</b>	170 m <sup>3</sup> /h (Speed 1 <sup>(1)</sup> )	170 m <sup>3</sup> /h (3,5 volts <sup>(1)</sup> )
<b>Size 6</b>	300 m <sup>3</sup> /h (Speed 1 <sup>(1)</sup> )	300 m <sup>3</sup> /h (3,5 volts <sup>(1)</sup> )
<b>Size 7</b>	700 m <sup>3</sup> /h (Speed 1 <sup>(1)</sup> )	700 m <sup>3</sup> /h (3,5 volts <sup>(1)</sup> )

(1) Normal usage

■ The operation of the electric heater must be fan-controlled.

Power to the electrical heaters should be cut and the fan delay activated whenever the fan motor assembly is stopped intentionally or unintentionally.

A two-part safety system is used to protect units equipped with electrical heaters (fig. 9) from accidental overheating:

- The mechanical safety thermostat with automatic reset.
- The thermo fuse.

**Warning:** Never connect several fan coil unit motors in parallel on the same thermostat.

If the thermo fuse is blown, then the electrical heater must be replaced.

- Remove the fan motor assembly (see the section "Removing the fan motor assembly").
- Undo the screws on the electrical heater.

Perform these steps in reverse to fit the new electrical heater.

## 5 - SERVICING AND MAINTENANCE

---

The unit must be serviced periodically between the heating and cooling seasons. In particular, components prone to clogging (filter, condensate drain pan, coil, etc.) must be checked.



**Disconnect the electrical and hydraulic supplies to the unit before carrying out any work and wait at least 20 mins before working on or near the heating elements.**



**For your safety, wear protective gloves to prevent the risk of burns from hot pipes.**

### 5.1 - Air filter

The filter is crucial to the correct operation of the unit. Without it, the heat exchange coil would become clogged, the performance would drop and the unit's sound level and electrical consumption would increase.

**42NH** is equipped with a G3 filter (optional). We recommend replacing it annually. CARRIER recommends regular inspections of the filter's appearance in order to define the frequency with which it should be replaced, which varies depending on the premises and the operating conditions.

The unit may be supplied without a filter at the customer's request. **The customer must ensure at least G3 upstream filtration. Failure to do so will lead to loss of the motor warranty cover.**

The filter should never be cleaned using water or detergent products, which could cause the spread of bacteria.

- **Accessing the filter, I, Y, H, U models:**
  - **Suspended ceiling T2 to T5 (Fig. 10)**
  - Unscrew the 4 lower panels screws on the FMA side (a)
  - Ensure the filter is supported as it is lowered (b)
  - Perform the steps in reverse to reassemble
  - **"Base unit only" models without plenum or return air sleeves (T6 and T7 only) (Fig. 11)**
  - Mark the three G3 filter clips (a)
  - Release the filter from the clips
  - **Models with plenum or return air sleeves (T6 and T7 only) (Fig. 12)**
  - Press the two filter access bolts (a)
  - Support the access panel as it is lowered and release the filter from its housing (b)

### 5.2 - Condensate drain pan

The main condensate drain pan and the pan extension must be kept clean. The pans and drainage fittings may be completely cleaned using non-abrasive, water-based detergents. Also check periodically that the drain pipe is not blocked, bent or kinked, and has the required gradient of  $-0^{\circ}/+2^{\circ}$  along its entire length.

Before starting up the unit, check that the water flows properly into the condensate pan by pouring some water into it.

- **Removing the pan:**

**Firstly, disconnect the pump (if present) and the condensate drain.**

- Refer to the "Removal of the coil" section to remove the pan.



**Note: Before starting up the unit, check that the water flows properly into the condensate pan by pouring some water into it. If the flow is not correct, look for possible causes of the problem.**



## 5 - SERVICING AND MAINTENANCE

---

### 5.3 - Fan motor assembly

Periodically check the cleanliness of the impeller and the motor. If necessary, clean them using a vacuum cleaner, taking care not to damage them.

The electric motor's bearings are lubricated for life and do not require specific maintenance.

- **Removing the fan motor assembly (GMV):**



**WARNING:** Disconnect the power supply to the unit before carrying out any work on the unit.

- **Suspended ceiling (Fig. 13) :**
- Remove the removable lower panel (a) using the 4 screws.
- Ensure the filter is supported as it is lowered as the only support is provided by the removable panel.
- Disconnect the electrics for the FMA (refer to the note below according to the type of motor in the unit).
- If one or more electrical heaters are fitted, these must be disconnected from the control panel, then the lower coil access panel must be removed using the 4 screws.
- Undo and remove the 4 FMA retaining screws on the lateral panels (b).
- Support the FMA platform as it is lowered, following the recesses (not present on T6 and T7) provided in the lateral panels (c).
- Perform the steps in reverse to reassemble, taking care to ensure the insulation is not damaged.

**Note : Disconnection differs depending on the type of fan motor assembly:**

- Asynchronous motor: disconnect the motor wiring loom from the unit's internal wall using the quick-release connector.
- Brushless motor: disconnect the wiring loom from the motor using the quick-release connector
- Brushless motor - T7 only: disconnect the wiring loom from the motor using the connectors (supply and control)

### 5.4 - Heat exchange coil

A clean coil is crucial to the efficiency of the unit. If necessary, clean the coil with a vacuum cleaner, taking care not to damage the fins.

If the coil must be disassembled on account of a leak:

Disconnect the electrical supply to the unit before carrying out any work.

**Removing the coil :**

- **Suspended ceiling :**

**Firstly, disconnect the coil.**

- Undo the 4 screws from the hydraulic coil (Fig. 14.a)
- Remove the removable lower panel (b) using the 4 screws.
- Ensure the pan + coil are held securely
- Remove the coil + pan by tilting the assembly on the manifold side downwards.
- Perform the steps in reverse to reassemble.

## 6 - REGULATIONS

---



Declaration of Conformity UE

This unit complies with the provisions of European Directives:

2006/42/EC (Machinery)

2014/30/EU (EMC)

2011/65/EU (RoHS)

2009/125/EC (Eco Design) et règlement 327/2011/UE

REGULATION (EC) No 1907/2006 (REACH)



UK Declaration of Conformity

This unit complies with the requirements of:

Supply of Machinery (Safety) Regulations 2008

Electromagnetic Compatibility Regulations 2016

The Restriction of the Use of Certain Hazardous Substances in Electrical and Electronic Equipment Regulations 2012

The Ecodesign for Energy-Related Products and Energy Information Regulations 2019, and following amendments

UK REACH Regulations 2019

Importateur pour le Royaume-Uni :

Toshiba Carrier UK Ltd, Porsham Close, Roborough, Plymouth, PL6 7DB

## 7 - TESTING & WARRANTY

---

All our units are tested and proven before leaving the factory.

They are guaranteed against all manufacturing defects. CARRIER shall not be held liable for any type of corrosion. CARRIER's warranty does not cover damage resulting from incorrect electrical wiring, inadequate electrical or thermal protection or failure to use a filter.

Work performed on the motor by the installer will invalidate the corresponding warranty.

