

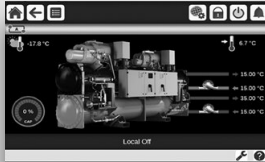

INSTALLATION, OPERATION AND MAINTENANCE INSTRUCTIONS

SmartVu™



Water-Cooled and heat pump variable speed
Liquid Chillers
AquaForce® PUREtec greenspeed with
R1234ze(E) or optionally with R515B refrigerant

30XW-VZE / 30XWHVZE 451-1301

Nominal cooling capacity: 270 - 1688 kW - 50Hz

AQUA FORCE greenspeed
PUREtec

CONTENTS

1 - INTRODUCTION	4
1.1 - Installation safety considerations	4
1.2 - Equipment and components under pressure	6
1.3 - Maintenance safety considerations	6
1.4 - Repair safety considerations	7
2 - PRELIMINARY CHECKS	9
2.1 - Check equipment received.....	9
2.2 - Moving and sitting the unit.....	9
3 - DIMENSIONS, CLEARANCES	10
3.1 - 30XW-VZE/30XWHVZE 451-651.....	10
3.2 - 30XW-VZE/30XWHVZE 851-1301.....	11
4 - PHYSICAL AND ELECTRICAL DATA	12
4.1 - Physical data	12
4.2 - Electrical data.....	13
4.3 - Short-circuit stability current	14
4.4 - Compressor electrical data.....	14
4.5 - Compressor usage per circuit (A, B).....	14
5 - ELECTRICAL CONNECTION	16
5.1 - Power supply.....	16
5.2 - Voltage phase imbalance (%).....	16
5.3 - Power connection.....	16
5.4 - Recommended wire sections	16
5.5 - Power cable entry.....	16
5.6 - Field control wiring	16
5.7 - 24 and 230 V power reserve for the user	16
6 - APPLICATION DATA	17
6.1 - 30XW-VZE /30XWHVZE Operating limits	17
6.2 - Condenser-side installation recommendation	17
6.3 - Minimum chilled water flow	17
6.4 - Maximum chilled water flow	17
6.5 - Condenser water flow rate	17
6.6 - Standard and optional number of water passes.....	18
6.7 - Evaporator and condenser water flow rates.....	18
6.8 - Variable flow evaporator.....	18
6.9 - System minimum water volume	18
6.10 - Evaporator pressure drop curves.....	19
6.11 - Condenser pressure drop curves	19
7 - WATER CONNECTIONS	20
7.1 - Operating precautions.....	20
7.2 - Water connections.....	21
7.3 - Flow control.....	21
7.4 - Evaporator and condenser water box bolt tightening	21
7.5 - Operation of two units in master/slave mode	21
8 - HEAT PUMPS 30XWHVZE	22
8.1 - Physical data for heat pumps	22
8.2 - Electrical data for heat pumps.....	22
8.3 - Dimensions and clearances for heat pumps	22
8.4 - Operating range for heat pumps	22
8.5 - Operating modes for heat pumps.....	22

The illustrations on the front cover and inside this document are for illustrative purposes only and not part of any offer for sale or contract.

CONTENTS

9 - MAJOR SYSTEM COMPONENTS AND OPERATION DATA	23
9.1 - Compressor.....	23
9.2 - Oil filter	23
9.3 - Refrigerant.....	23
9.4 - Lubricant.....	23
9.5 - Oil supply solenoid valve.....	23
9.6 - Pressure vessels.....	23
9.7 - High Pressure SRMCR safety loop.....	24
10 - OPTIONS AND ACCESSORIES	25
11 - STANDARD MAINTENANCE	27
11.1 - Level 1 maintenance	27
11.2 - Level 2 maintenance	27
11.3 - Level 3 (or higher) maintenance.....	27
11.4 - Tightening of the electrical connections.....	27
11.5 - Tightening torques for the main bolts and screws	28
11.6 - Evaporator and condenser maintenance.....	28
11.7 - Compressor maintenance	28
11.8 - Frequency variator maintenance	29
11.9 - High pressure safety loop periodic test	29
12 - START-UP CHECKLIST FOR 30XW-VZE LIQUID CHILLERS (USE FOR JOB FILE)	30

This manual applies to the following unit types:

- 30XW-VZE High-efficiency units
- 30XWHVZE Heat Machine high-efficiency units

For the operation of the control please refer to the SmartVu™ control manual.

The cover photograph is for illustrative purposes only and is not part of any offer for sale or contract.

1 - INTRODUCTION

The 30XW-VZE / 30XWHVZE units are designed to cool or heat water (or brine) for the air conditioning of buildings and industrial processes.

Prior to the initial start-up of the 30XW-VZE / 30XWHVZE units, the people involved in the on-site installation, start-up, operation, and maintenance of this unit should be thoroughly familiar with these instructions and the specific project data for the installation site (Machine room, etc).

They are designed for an operating life of 15 years by assuming a 75% utilisation factor; that is approximately 100,000 operating hours.

This manual provides the necessary information to familiarize yourself with the control system before performing start-up procedures. The procedures in this manual are arranged in the sequence required for machine installation, start-up, operation and maintenance.

Always ensure that all required safety measures are followed, including those in this document, such as: wearing protective clothing (gloves, safety glasses and shoes) using appropriate tools, employing qualified and skilled technicians (electricians, refrigeration engineers) fully trained in the use of flammable refrigerants and following local regulations (see annexe E in EN 378-4-Guidelines for repairs of equipment using flammable refrigerants).

To find out, if these products comply with European directives (machine safety, low voltage, electromagnetic compatibility, equipment under pressure etc.) check the declarations of conformity for these products.

According to ISO-819, R1234ze(E) is classified in safety group A2L: Lower flammability. One of the characteristic of this refrigerant is the absence of flammable mixture with air under 21°C of ambience and controlled humidity conditions. However when humidity or temperature goes up, this refrigerant can become flammable and can represent a potential danger if flammability risks are not properly mitigated within the machine room installation.

Local building codes and safety standards shall be followed. In absence of local codes and standards, please refer to EN-378 (2012) (Safety requirements for substances classified A2) or to ISO-5149 (2014) (for substances classified A2L) as a guide. Customer shall obtain approval from the local building authorities.

For further details on physical properties, flammability & toxicity characteristics, hazards Identification, installation safety requirements, etc, refer to standards such as:

- ASHRAE 34, EN-378, ISO-817 and ISO-5149
- Safety Data Sheet (SDS) supplied by the refrigerant manufacturer
- European union's REACH database (Registration, Evaluation, Authorisation and Restriction of Chemicals)

1.1 - Installation safety considerations

The 30XW-VZE / 30XWHVZE liquid chillers are classified as "indirect heat exchange system" and are designated to be installed in a special machinery room (Class C as per ISO-5149 and EN-378) where only authorized personnel have access, who are acquainted with general and special safety precautions of the establishment and are qualified and trained in monitoring and maintenance. The access limitation device must be installed by the customer (e.g. cut-off, enclosure).

The refrigerant R1234ze(E) falls into refrigerant safety group A2L in accordance to ISO-5149 and A2 in accordance to EN-378. No Charge limitations apply for the level of occupancy is 'C'. Please refer to these standards for further details. This level needs to be confirmed by the customer.

After the unit has been received, when it is ready to be installed or reinstalled, and before it is started up, it must be inspected for damage. Check that the refrigerant circuit(s) is (are) intact, especially that no components or pipes have shifted (e.g. following a shock). If in doubt, carry out a leak tightness check and verify with the manufacturer that the circuit integrity has not been impaired. If damage is detected upon receipt, immediately file a claim with the shipping company.

Carrier strongly recommends employing a specialised company to unload the machine.

It is compulsory to wear personal protection equipment.

Do not remove the skid or the packaging until the unit is in its final position. These units can be moved with a fork lift truck, as long as the forks are positioned in the right place and direction on the unit.

The units can also be lifted with slings, using only the designated lifting points marked on the unit.

Use slings or lifting beams with the correct capacity, and always follow the lifting instructions on the certified drawings supplied with the unit. Do not tilt the unit more than 15°.

Safety is only guaranteed, if these instructions are carefully followed. If this is not the case, there is a risk of material deterioration and injuries to personnel.

1 - INTRODUCTION

Never cover any protection devices.

This applies to the relief valves in the refrigerant or heat transfer medium circuits, and the pressure switches.

Ensure that the valves are correctly installed, before operating the unit.

DO NOT OBSTRUCT ANY PROTECTIVE DEVICES:

This applies to any fusible plugs, rupture disks and valves fitted on the refrigerant or heat transfer fluid circuits. Check whether the original protection plugs are still present at the valve outlets. These plugs are generally made of plastic and should not be used. If they are still present, please remove them. Fit devices at the valve or discharge piping outlets to prevent the penetration of foreign bodies (dust, building debris, etc.) and atmospheric agents (water can form rust or ice). These devices, as well as the discharge piping, must not impair operation or lead to a pressure drop that is higher than 10% of the set pressure.

CLASSIFICATION AND CONTROL:

In accordance with the Pressure Equipment Directive and national usage monitoring regulations in the European Union, the protective devices fitted to these machines are classified as follows:

	Safety device ⁽¹⁾	Device for damage limitation in the event of an external fire ⁽²⁾
Refrigerant Side		
High pressure safety loop ⁽³⁾	X	
External relief valve ⁽⁴⁾		X
Rupture disk		X
Heat transfer fluid side		
External relief valve	(5)	(5)

(1) Classified for protection in normal service situations.

(2) Classified for protection in abnormal service situations. These accessories are sized for fires with a thermal flow of 10kW/m². No combustible matter should be placed within 6.5m of the unit.

(3) High pressure safety loop = SRMCR as described in component section of this manual and in electrical diagram.

(4) The instantaneous overpressure limitation of 10% of the operating pressure does not apply to this abnormal service situation.

The control pressure can be higher than the service pressure. In this case, either the design temperature or the high pressure switch ensures that the service pressure is not exceeded in normal service situations.

(5) The selection of these relief valves must be made by the personnel responsible for completing the hydraulic installation.

All factory-installed relief valves are lead-sealed to prevent any calibration change. The external relief valves must always be vented to outside if the units are installed in a closed space. Refer to the installation regulations, for example those of European standard EN 378 and EN 13136. These pipes must be installed in a way that ensures that people and property are not exposed to vented refrigerant. As the fluids can be diffused in the air, ensure that refrigerant is discharged away from building air intakes, relief valves must be checked periodically. The valves must be checked periodically.

The safety device shall be tested at least once a year to verify good operation and cut out value.

An example of test procedure without removing the pressure switch is given in Section 13.8 of this manual.

If the relief valves are installed on a change-over manifold, this is equipped with a relief valve on each of the two outlets. Only one of the two relief valves is in operation, the other one is isolated. Never leave the change-over valve in the intermediate position, i.e. with both ways open (locate the control element in the stop position). If a relief valve is removed for checking or replacement please ensure that there is always an active relief valve on each of the change-over valves installed in the unit.

All factory-installed relief valves are lead-sealed to prevent any calibration change.

The external relief valves are designed and installed to ensure damage limitation in case of a fire.

In accordance with the regulations applied for the design, the European directive on equipment under pressure and in accordance with the national usage regulations:

- These relief valves (and rupture disk if used) are not safety accessories but damage limitation accessories in case of a fire,
- The high pressure switches are the safety accessories.

The relief valve must only be removed if the fire risk is fully controlled and after checking that this is allowed by local regulations and authorities. This is the responsibility of the operator.

When the unit is subjected to fire, safety devices prevent rupture due to over-pressure by releasing refrigerant. The fluid may then be decomposed into toxic residues when subjected to the flame:

- Stay away from the unit
- Set up warnings and recommendations for personnel in charge to stop the fire.
- Fire extinguishers appropriate to the system and the refrigerant type must be easily accessible.

The external relief valves must be connected to discharge pipes for units installed in a room. Refer to the installation regulations, for example those of European standards EN-378.

These standards include a sizing method and examples for configuration and calculation. Under certain conditions they permit connection of several valves to the same discharge pipe.

Carrier recommends using flexible hose to connect the relief valves to discharge pipe. Special care shall be taken so that coupling to discharge pipe is not creating mechanical stress on relief valve connection.

These pipes must be installed in a way that ensures that people and property are not exposed to refrigerant leaks. These fluids may be diffused in the air, but far away from any building air intake, or they must be discharged in a quantity that is appropriate for a suitably absorbing environment (Note that the R1234ze(E) and R515B refrigerants are heavier than air).

It is recommended to install an indicating device to show if part of the refrigerant has leaked from the valve. The presence of oil at the outlet orifice is a useful indicator that refrigerant has leaked. Keep this orifice clean to ensure that any leaks are obvious.

The calibration of a valve that has leaked is generally lower than its original calibration. The new calibration may affect the operating range. To avoid a nuisance tripping or leaks, replace or re-calibrate the valve.

Periodic check of the relief valves: See paragraph "Maintenance safety considerations".

Provide a drain in the discharge circuit, close to each relief valve, to avoid an accumulation of condensate or rain water.

Ensure good ventilation, as accumulation of refrigerant in an enclosed space can displace oxygen and cause asphyxiation or explosions.

Inhalation of high concentrations of vapour is harmful and may cause heart irregularities, unconsciousness, or death. Vapour is heavier than air and reduces the amount of oxygen available for breathing. These products cause eye and skin irritation. Decomposition products are hazardous.

1 - INTRODUCTION

1.2 - Equipment and components under pressure

The units are intended to be stored and operate in an environment where the ambient temperature must not be less than the lowest allowable temperature indicated on the nameplate. See section "Pressure vessels".

1.3 - Maintenance safety considerations

Refer to EN378 norm for safe use of refrigerant in machinery rooms, especially for appropriate ventilation when using R1234ze A2L fluid.

Engineers working on the electric or refrigeration components must be authorized, trained and fully qualified to do so.

Never clean the chiller with a fluid at a temperature higher than 45°C. An over temperature could generate an over pressure and make the relief valve discharge the refrigerant.

All refrigerant circuit repairs must be carried out by a trained person fully qualified to work on these units who must have been:

- Trained and be familiar with the equipment and the installation (including the refrigerant used).
- Informed of the risks of possible explosive atmospheres and can prevent them. They also have to be informed of the working procedure for preventing the risk of flammable refrigerant leaking into the atmosphere as much as possible

All welding operations must be carried out by qualified specialists

Maintenance operation have to be done according to national rules and regulations that apply to explosive atmospheres (e.g. reference to EN 1127-1)

When performing service on the refrigeration circuit, ventilate the area prior to performing any work and check for presence of refrigerant. During service operation, continue to ventilate the air using the machine room ventilation or temporary fans.

Before opening a refrigerant circuit, purge and consult the pressure gauges. Reclaim the refrigerant using a proper refrigerant reclaim device and reclaim cylinders. The refrigerant circuit should be pumped down and then purged with nitrogen before servicing.

During a brazing operation, the refrigerant circuit should be purged with nitrogen. Also when servicing the refrigerant circuit, all ignition sources should be disabled.

The insulation must be removed and heat generation must be limited by using a wet cloth.

Any manipulation (opening or closing) of a shut-off valve must be carried out by a qualified and authorised engineer. These procedures must be carried out with the unit shut-down.

NOTE: The unit must never be left shut down with the liquid line valve closed, as liquid refrigerant can be trapped between this valve and the expansion device (This valve is situated on the liquid line before the filter drier). In case of presence of a shut-off valve on the suction line (between evaporator and compressor -factory option n°92), never close at the same time the shut-off valve situated on the discharge line (between compressor and condenser). One exception can be made in case of compressor removal from the refrigerant circuit.

Equip the engineers that work on the unit as follows:

Personal protection equipment (PPE) ⁽¹⁾	Operations		
	Handling	Maintenance, service	Welding or brazing ⁽²⁾
Protective gloves, eye protection, safety shoe, protective clothing.	X	X	X
Ear protection.		X	X
Filtering respirator.			X

(1) We recommend to follow the instructions in EN 378-3.

(2) Performed in the presence of A1 refrigerant according to EN 378-1.

Never work on a unit that is still energized.

Never work on any of the electrical components, until the general power supply to the unit has been cut using the disconnect switch(es) in the control box(es).

If any maintenance operations are carried out on the unit, lock the power supply circuit in the open position ahead of the machine.

ATTENTION: The frequency variators used in the 30XW-VZE/30XWHVZE units are equipped with capacitor batteries with a discharge time of twenty (20) minutes after disconnecting the power. After disconnecting the power to the control box, wait twenty minutes before opening the control box.

If the work is interrupted, always ensure that all circuits are still deenergized before resuming the work.

ATTENTION: Even if the unit has been stopped, the power circuit remains energized, unless the unit or circuit disconnect switch is open. Refer to the wiring diagram for further details. Attach appropriate safety labels.

CAUTION: INTERNAL FAILURE HAZARD

An internal failure in the frequency converter can result in serious injury, when the frequency converter is not properly closed.

Ensure that all safety covers are in place and securely fastened, before applying power.

1 - INTRODUCTION

OPERATING CHECKS:

IMPORTANT INFORMATION REGARDING THE REFRIGERANT USED:

This product contains fluorinated greenhouse gas covered by the Kyoto protocol.

Standard unit:

- Fluid type: R1234ze(E)
- Global Warming Potential (GWP): 7 (source IPCC Assessment Report 4)

Unit with option 330:

- Fluid type: R515B
- Global Warming Potential (GWP): 293 (source IPCC Assessment Report 4)

These refrigerant are classified group 2 “non-dangerous” according to the criteria of Pressure Equipment Directive (PED) both 97/23/CE and 2014/68/CE.

CAUTION:

- **Any handling of refrigerant contained in this product must comply with the F-Gas Directive N° 517/2014 and any other applicable local legislation.**
- **Ensure that the refrigerant is never released to the atmosphere during installation, maintenance or equipment disposal.**
- **The deliberate gas release into the atmosphere is strictly not allowed.**
- **If a refrigerant leak is detected, ensure that it is stopped and repaired as quickly as possible.**
- **Only a qualified and certified personnel can perform installation operations, maintenance, refrigerant circuit leak test as well as the equipment disposal and the refrigerant recovering.**
- **The gas recovery for recycling, regeneration or destruction is at customer charge.**
- **The customer has to carry out periodic leak tests**

In the European Union, article 2 of regulation (EU) No. 517/2014 makes these mandatory and sets their frequency. The table below shows this frequency, as originally published in the regulation. Check whether an inspection frequency is also set by other regulations or standards applicable to your system (e.g. EN 378, ISO5149, etc.).

System WITHOUT leakage detection		No check	12 months	6 months	3 months
System WITH leakage detection		No check	24 months	12 months	6 months
Refrigerant charge/circuit (CO ₂ equivalent)		< 5 tons	5 ≤ charge < 50 tons	50 ≤ charge < 500 tons	Charge > 500 tons
Refrigerant charge/Circuit (kg)	R32 (GWP 675)	Charge < 7,4 kg	7,4 ≤ charge < 74,1 kg	74,1 ≤ charge < 740,7 kg	Charge > 740,7 kg
	R134a (GWP 1430)	Charge < 3,5 kg	3,5 ≤ charge < 34,9 kg	34,9 ≤ charge < 349,7 kg	Charge > 349,7 kg
	R407C (GWP 1774)	Charge < 2,8 kg	2,8 ≤ charge < 28,2 kg	28,2 ≤ charge < 281,9 kg	Charge > 281,9 kg
	R410A (GWP 2088)	Charge < 2,4 kg	2,4 ≤ charge < 23,9 kg	23,9 ≤ charge < 239,5 kg	Charge > 239,5 kg
	R515B (GWP 293)	Charge < 17,1 kg	17,1 ≤ charge < 170,6 kg	170,6 ≤ charge < 1706,5 kg	Charge > 1706,5 kg
	HFO's : R1234ze(E)	No requirement			

(*) From 01/01/2017, customer installations must be equipped with a leakage detection system

- A logbook must be established for the systems that require a tightness check. It should contain the quantity and the type of fluid present within the installation (added and recovered), the quantity of recycled fluid/regenerated/destroyed, the date and output of the leak test, the designation of the operator and its belonging company, etc.
- Contact your local dealer or installer if you have any questions.

PROTECTION DEVICE CHECKS:

- Periodic inspections of the safety devices and external overpressure devices (external relief valves) must be carried out in accordance with national regulations.

The company or organisation that conducts a pressure switch test shall establish and implement a detailed procedure to fix:

- Safety measures
- Measuring equipment calibration
- Validating operation of protective devices
- Test protocols
- Recommissioning of the equipment.

An example of test procedure without removing the pressure switch is given in Section 11.9 of this manual. Consult Carrier Service for this type of test.

CAUTION: If the test leads to replacing the pressure switch, it is necessary to recover the refrigerant charge, these pressure switches are not installed on automatic valves (Schraeder type).

At least once a year thoroughly inspect the protection devices (valves). If the machine operates in a corrosive environment, inspect the protection devices more frequently.

Regularly carry out leak tests and immediately repair any leaks (follow local codes)

Ensure regularly that the vibration levels remain acceptable and close to those at the initial unit start-up.

Change the refrigerant when there are equipment failures, following a procedure such as the one described in NF E29-795 or carry out a refrigerant analysis in a specialist laboratory.

If the refrigerant circuit remains open for longer than a day after an intervention (such as a component replacement), the openings must be plugged and the circuit must be charged with nitrogen (inertia principle). The objective is to prevent penetration of atmospheric humidity and the resulting corrosion on the internal walls and on non-protected steel surfaces.

1.4 - Repair safety considerations

Equip the engineers that work on the unit with the protections described in section 1.3 above.

It is compulsory to wear personal protection equipment and a detector of explosive atmospheres.

The insulation must be removed and warming up must be limited by using a wet cloth.

Before opening the unit, always ensure that the circuit has been purged.

If work on the evaporator is required, ensure that the piping from the compressor is no longer pressurised (as the valve is not leaktight in the compressor direction.)

1 - INTRODUCTION

All installation parts must be maintained by the personnel in charge, in order to avoid material deterioration and injuries to people. Faults and leaks must be repaired immediately. The authorized technician must have the responsibility to repair the fault immediately. Each time repairs have been carried out to the unit, the operation of the protection devices must be re-checked.

Comply with the regulations and recommendations in unit and HVAC installation safety standards, such as: EN-378, ISO-5149, etc.

If a leak occurs or if the refrigerant becomes contaminated (e.g. by a short circuit in a motor) remove the complete charge using a recovery unit and store the refrigerant in mobile containers.

Repair the leak detected and recharge the circuit with the total quantity of the original refrigerant (either R1234ze(E) or R515B), as indicated on the unit name plate. Certain parts of the circuit can be isolated. Only charge liquid refrigerant at the liquid line.

Ensure that you are using the correct refrigerant type before recharging the unit.

Charging any refrigerant other than the original charge type stated on the nameplate will impair machine operation and can even lead to a destruction of the compressors. The compressors operating with this refrigerant type are lubricated with a specific synthetic polyolester oil.

Do not use oxygen to purge lines or to pressurize a machine for any purpose. Pressurised air mixtures or gases containing oxygen can be the cause of an explosion. Oxygen reacts violently with oil and grease. Nitrogen should be used to purge the system. It should also be used during brazing.

Never exceed the specified maximum operating pressures. Verify the allowable maximum high- and low-side test pressures by checking the instructions in this manual and the pressures given on the unit name plate.

Do not use air for leak testing. Use only refrigerant or dry nitrogen.

Do not unweld or flamecut the refrigerant lines or any refrigerant circuit component until all refrigerant (liquid and vapour) has been removed from chiller and the system has been purged with nitrogen. Traces of vapour should be displaced with dry air nitrogen. Refrigerant in contact with an open flame produces toxic gases.

The necessary protection equipment must be available, and appropriate fire extinguishers for the system and the refrigerant type used must be within easy reach.

Do not siphon refrigerant.

Avoid contact with liquid refrigerant on the skin or splashing it into the eyes. Use safety goggles. Wash any spills from the skin with soap and water. If liquid refrigerant enters the eyes, immediately and abundantly flush the eyes with water and consult a doctor.

The accidental releases of the refrigerant, due to small leaks or significant discharges following the rupture of a pipe or an unexpected release from a relief valve, can cause frostbites and burns to personnel exposed. Do not ignore such injuries. Installers, owners and especially service engineers for these units must:

- Seek medical attention before treating such injuries.
- Have access to a first-aid kit, especially for treating eye injuries.

We recommend to apply standard EN-378.

Never apply an open flame or live steam to a refrigerant container. Dangerous overpressure can result.

During refrigerant removal and storage operations follow applicable regulations. These regulations, permitting conditioning and recovery of halogenated hydrocarbons under optimum quality conditions for the products and optimum safety conditions for people, property and the environment are described in standard NF E29-795.

Any refrigerant transfer and recovery operations must be

carried out using a transfer unit. An SAE connector (respectively 1/2" for R1234ze(E) and 3/8" for R515B) on the manual liquid line valve is supplied with all units for connection to the transfer station. The units must never be modified to add refrigerant or oil charging devices, removal or purging devices. All these features are provided with the units. Please refer to the certified dimensional drawings for the units.

Never use the compressor as a vacuum pump. It would damage the compressor.

Do not re-use disposable (non-returnable) cylinders or attempt to refill them. It is dangerous and illegal. Proper refrigerant cylinders designated and marked for the original refrigerant stated on the nameplate should be used. When cylinders are empty, evacuate the remaining gas pressure, and move the cylinders to a place designated for their recovery. Do not incinerate.

ATTENTION: Only use refrigerant, in accordance with AHRI 700-2014 (Air conditioning, Heating and Refrigeration Institute). The use of any other refrigerant may expose users and operators to unexpected risks.

Do not attempt to remove refrigerant circuit components or fittings, while the machine is under pressure or while it is running. Be sure pressure is at 0 kPa and has been purged with nitrogen before removing components or opening a circuit.

Do not attempt to repair or recondition any safety devices when corrosion or build-up of foreign material (rust, dirt, scale, etc.) is found within the valve body or mechanism. If necessary, replace the device. Do not install relief valves in series or backwards.

ATTENTION: No part of the unit must be used as a walk-way, rack or support. Periodically check and repair or if necessary replace any component or piping that shows signs of damage.

The refrigerant lines can break under the weight and release refrigerant, causing personal injury.

Do not climb on a machine. Use a platform, or staging to work at higher levels.

Use mechanical lifting equipment (crane, hoist, winch, etc.) to lift or move heavy components. For lighter components, use lifting equipment when there is a risk of slipping or losing your balance.

Use only original replacement parts for any repair or component replacement. Consult the list of replacement parts that corresponds to the specification of the original equipment.

Do not drain water circuits containing industrial brines, without informing the technical service department at the installation site or a competent body first.

Close the entering and leaving water shutoff valves and purge the unit water circuit, before working on the components installed on the circuit (screen filter, pump, water flow switch, etc.).

Do not loosen the water box bolts until the water boxes have been completely drained.

Periodically inspect all valves, fittings and pipes of the refrigerant and hydraulic circuits to ensure that they do not show any corrosion or any signs of leaks.

It is recommended to wear ear defenders, when working near the unit and the unit is in operation.

2 - PRELIMINARY CHECKS

2.1 - Check equipment received

- Inspect the unit for damage or missing parts. If damage is detected, or if shipment is incomplete, immediately file a claim with the shipping company.
- Confirm that the unit received is the one ordered. Compare the name plate data with the order.
- The unit name plate must include the following information:
 - Version number
 - Model number
 - CE marking
 - Serial number
 - Year of manufacture and test date
 - Fluid being transported
 - Refrigerant used and refrigerant class
 - Refrigerant charge per circuit
 - Containment fluid to be used
 - PS: Min./max. allowable pressure (high and low pressure side)
 - TS: Min./max. allowable temperature (high and low pressure side)
 - Pressure switch cut-out pressures
 - Unit leak test pressure
 - Voltage, frequency, number of phases
 - Maximum current drawn
 - Maximum power input
 - Unit net weight
- Confirm that all accessories ordered for on-site installation have been delivered, and are complete and undamaged.

The unit must be checked periodically during its whole operating life to ensure that no shocks (handling accessories, tools etc.) have damaged it. If necessary, the damaged parts must be repaired or replaced. See also chapter "Standard maintenance".

2.2 - Moving and sitting the unit

2.2.1 - Moving

See chapter "Installation safety considerations".

CAUTION: Only use slings at the designated lifting points which are marked on the unit.

2.2.2 - Sitting the unit

Always refer to the chapter "Dimensions and clearances" to confirm that there is adequate space for all connections and service operations. For the centre of gravity coordinates, the position of the unit mounting holes, and the weight distribution points, refer to the certified dimensional drawing supplied with the unit.

Typical applications of these units are in refrigeration systems, and they do not require earthquake resistance. Earthquake resistance has not been verified.

Before siting the unit check that:

- the permitted loading at the site is adequate or that appropriate strengthening measures have been taken.
- the unit is installed level on an even surface (maximum tolerance is 5 mm in both axes).
- there is adequate space above the unit for air flow and to ensure access to the components.
- the number of support points is adequate and that they are in the right places.
- the location is not subject to flooding.

CAUTION: Lift and set down the unit with great care. Tilting and jarring can damage the unit and impair unit operation.

2.2.3 - Checks before system start-up

Before the start-up of the refrigeration system, the complete installation, including the refrigeration system must be verified against the installation drawings, dimensional drawings, system piping and instrumentation diagrams and the wiring diagrams.

During the installation test national regulations must be followed. If no national regulation exists, standards such EN-378 or ISO-5149 can be used as a guide.

External visual installation checks:

- Ensure that the machine is charged with refrigerant. Verify on the unit nameplate that the 'fluid being transported' is not nitrogen.
- Compare the complete installation with the refrigeration system and power circuit diagrams.
- Check that all protection documents and equipment provided by the manufacturer (dimensional drawings, P&ID, declarations etc.) to comply with the regulations are present.
- Verify that the environmental safety and protection and devices and arrangements provided by the manufacturer to comply with the regulations are in place.
- Verify that all document for pressure containers, certificates, name plates, files, instruction manuals provided by the manufacturer to comply with the regulations are present.
- Verify the free passage of access and safety routes.
- Check that ventilation in the plant room is adequate.
- Check that refrigerant detectors are present.
- Verify the instructions and directives to prevent the deliberate removal of refrigerant gases that are harmful to the environment.
- Verify the installation of connections.
- Verify the supports and fixing elements (materials, routing and connection).
- Verify the quality of welds and other joints.
- Check the protection against mechanical damage.
- Check the protection against heat.
- Check the protection of moving parts.
- Verify the accessibility for maintenance or repair and to check the piping.
- Verify the status of the valves.
- Verify the quality of the thermal insulation and of the vapour barriers
- Check the condition of the insulation of the 400 V cables.

3 - DIMENSIONS, CLEARANCES

3.1 - 30XW-VZE/30XWHVZE 451-651

refer to the dimensional drawings.

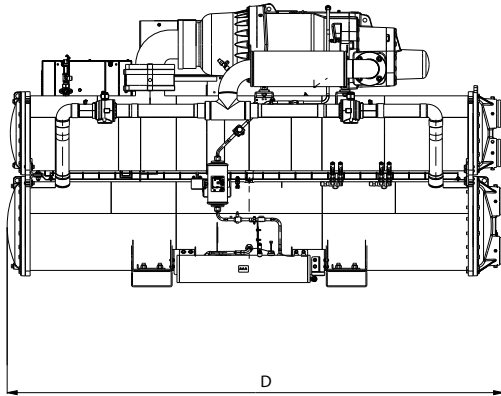
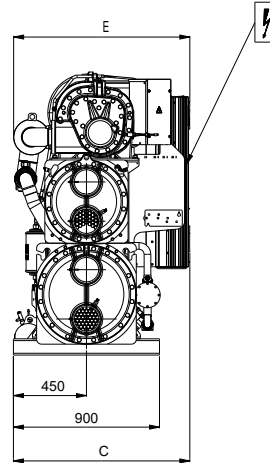
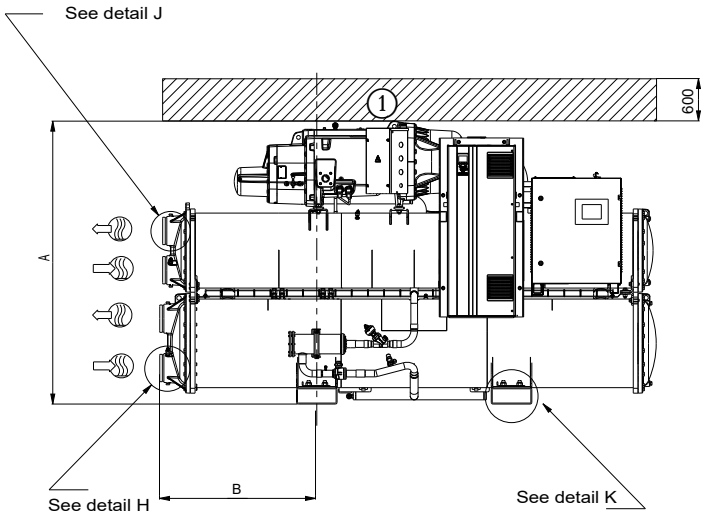

Dimensions en mm								
	A	B	C	D	E	F	G	H
30XW-VZE/30XWHVZE								
851	1998	1514	1164	4730	1162	219,1	219,1	4500
1001	1998	1514	1164	4730	1162	219,1	219,1	4500
1101	2051	1514	1164	4730	1264	219,1	219,1	4500
1201	2051	1514	1164	4730	1264	219,1	219,1	4500
1301	2051	1514	1164	4730	1264	219,1	219,1	4500

Legend

All dimensions are given in mm.

- ① Services clearances required
- ② Space required to remove cooler tubes
- Inlet water
- Outlet water
- Electrical supply entry

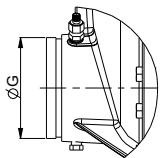
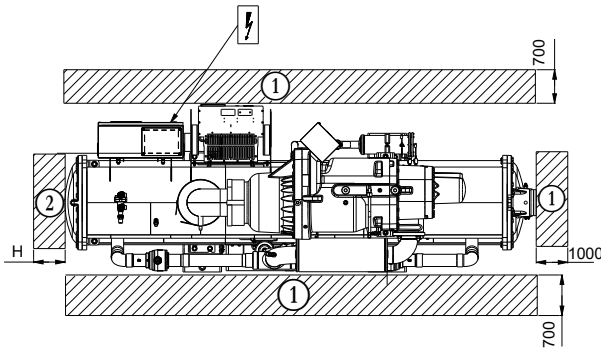

Detail H

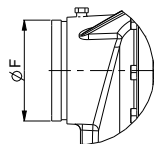

Detail J

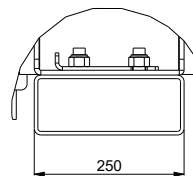

Detail K

NOTES:

- Drawings are not contractually binding. Before designing an installation, consult the certified dimensional drawings supplied with the unit or available on request.
- For the positioning of the fixing points, weight distribution and centre of gravity coordinates please

3 - DIMENSIONS, CLEARANCES

3.2 - 30XW-VZE/30XWHVZE 851-1301

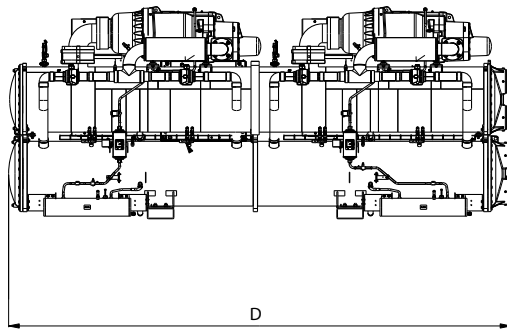
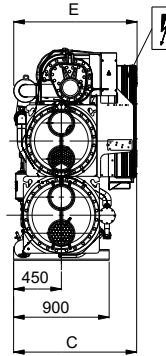
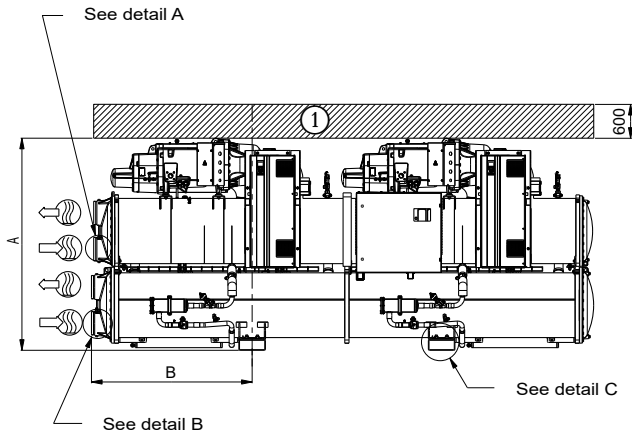

Dimensions en mm								
	A	B	C	D	E	F	G	H
30XW-VZE/30XWHVZE								
451	1743	968	1087	3059	1086	168,3	168,3	2800
501	1743	968	1087	3059	1086	168,3	168,3	2800
601	1948	1083	1137	3290	1237	219,1	219,1	3100
651	1948	1083	1137	3290	1237	219,1	219,1	3100

Legend

All dimensions are given in mm.

- ① Services clearances required
- ② Space required to remove cooler tubes
- Inlet water
- Outlet water
- Electrical supply entry

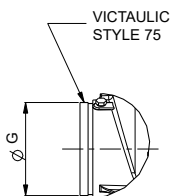
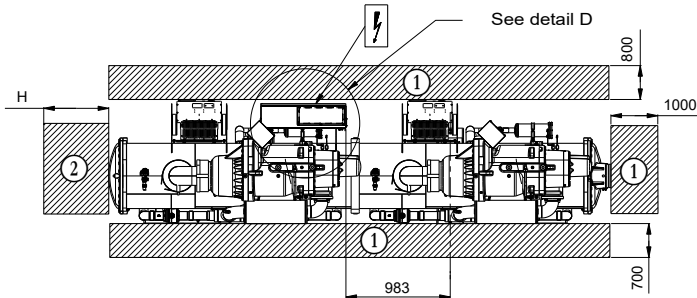

Detail A

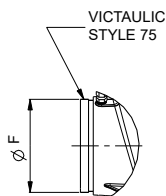

Detail B

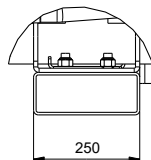

Detail C

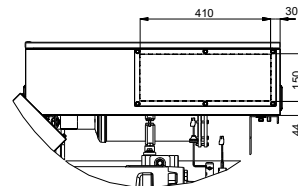

Detail D

NOTES:

- Drawings are not contractually binding. Before designing an installation, consult the certified dimensional drawings supplied with the unit or available on request.
- For the positioning of the fixing points, weight distribution and centre of gravity coordinates please refer to the dimensional drawings.

4 - PHYSICAL AND ELECTRICAL DATA

4.1 - Physical data

30XW-VZE/30XWHVZE		451	501	601	651	851	1001	1101	1201	1301
Sound levels - standard unit										
Sound power level ⁽¹⁾	dB(A)	103	103	103	103	104	104	104	104	104
Sound pressure level at 1 m ⁽²⁾	dB(A)	85	85	85	85	85	85	85	85	85
Sound levels - standard unit + option 257⁽³⁾										
Sound power level ⁽¹⁾	dB(A)	100	100	100	100	101	101	101	101	101
Sound pressure level at 1 m ⁽²⁾	dB(A)	82	82	82	82	82	82	82	82	82
Dimensions - standard unit										
Length	mm	3059	3059	3290	3290	4730	4730	4730	4730	4730
Width	mm	1087	1087	1237	1237	1164	1164	1264	1264	1264
Height	mm	1743	1743	1948	1948	1997	1997	2051	2051	2051
Operating weight⁽⁴⁾	kg	3223	3261	4263	4267	7477	7553	7731	7932	7970
Compressors Semi-hermetic 06T screw compressors, 50 r/s										
Circuit A	-	1	1	1	1	1	1	1	1	1
Circuit B	-	-	-	-	-	1	1	1	1	1
Refrigerant - standard unit										
R1234ze(E)										
Circuit A	kg	130	130	180	175	120	120	115	115	110
	teq CO ₂	0,1	0,1	0,2	0,2	0,1	0,1	0,1	0,1	0,1
Circuit B	kg	-	-	-	-	120	120	120	115	110
	teq CO ₂	-	-	-	-	0,1	0,1	0,1	0,1	0,1
Refrigerant - option 330										
R515B										
Circuit A	kg	132	132	183	178	122	122	117	117	112
	teq CO ₂	38,7	38,7	53,6	52,2	35,7	35,7	34,3	34,3	32,8
Circuit B	kg	-	-	-	-	122	122	122	117	112
	teq CO ₂	-	-	-	-	35,7	35,7	35,7	34,3	32,8
Oil - standard unit										
Circuit A	l	20	20	25	25	20	20	25	25	25
Circuit B	l	-	-	-	-	20	20	20	25	25
Capacity control										
SmartVu™, inverter-driven compressor, electronic expansion valve (EXV)										
Minimum capacity	%	20	20	20	20	10	10	10	10	10
Evaporator										
Multi-pipe flooded type										
Water volume	l	106	106	154	154	297	297	297	297	297
Water connections (Victaulic)	in	6	6	8	8	8	8	8	8	8
Drain and vent connections (NPT)	in	3/8	3/8	3/8	3/8	3/8	3/8	3/8	3/8	3/8
Max. water-side operating pressure	kPa	1000	1000	1000	1000	1000	1000	1000	1000	1000
Condenser										
Multi-pipe flooded type										
Water volume	l	112	112	165	165	340	340	340	340	340
Water connections (Victaulic)	in	6	6	8	8	8	8	8	8	8
Drain and vent connections (NPT)	in	3/8	3/8	3/8	3/8	3/8	3/8	3/8	3/8	3/8
Max. water-side operating pressure	kPa	1000	1000	1000	1000	1000	1000	1000	1000	1000

(1) In dB ref=10⁻¹² W, (A) weighting. Declared dualnumber noise emission values in accordance with ISO 4871 (with an associated uncertainty of +/-3dB(A)). Measured in accordance with ISO 9614-1 and certified by Eurovent.

(2) In dB ref 20µPa, (A) weighting. Declared dualnumber noise emission values in accordance with ISO 4871 (with an associated uncertainty of +/-3dB(A)). For information, calculated from the sound power level Lw(A).

(3) Option 257 = Low noise level

(4) Weight shown is guideline only. Please refer to the unit nameplate

4 - PHYSICAL AND ELECTRICAL DATA

4.2 - Electrical data

30XW-VZE /30XWHVZE		451	501	601	651	851	1001	1101	1201	1101
Power circuit										
Nominal power supply	V-ph-Hz	400-3-50								
Voltage range	V	360-440								
Control circuit		24 V via the built-in transformer								
Start-up current⁽¹⁾		Negligible (lower than maximum current drawn)								
Maximum power factor⁽²⁾	A	0,91-0,93	0,91-0,93	0,91-0,93	0,91-0,93	0,91-0,93	0,91-0,93	0,91-0,93	0,91-0,93	0,91-0,93
Cosine phi	A	> 0,98	> 0,98	> 0,98	> 0,98	> 0,98	> 0,98	> 0,98	> 0,98	> 0,98
Harmonic distortion rate⁽³⁾	A	35-45	35-45	35-45	35-45	35-45	35-45	35-45	35-45	35-45
Maximum power input⁽⁴⁾										
Circuit A	A	135	157	189	208	135	157	189	189	208
Circuit B	A	-	-	-	-	135	157	157	189	208
Eurovent current draw*										
Circuit A	A	129	148	180	197	129	149	180	180	197
Circuit B	A	-	-	-	-	129	149	149	180	197
Maximum current draw (Un)⁽⁴⁾										
Circuit A	%	210	245	295	325	210	245	295	295	325
Circuit B	A	-	-	-	-	210	245	245	295	325
Maximum current draw (Un -10%)⁽³⁾										
Circuit A	kW	220	260	313	345	220	260	313	313	345
Circuit B	kW	-	-	-	-	220	260	260	313	345
Maximum power input with option 150B⁽⁴⁾										
Circuit A	A	114	134	161	177	114	134	161	161	177
Circuit B	A	-	-	-	-	114	134	134	161	177
Maximum current draw (Un) with option 150B⁽⁴⁾										
Circuit A	A	180	213	257	283	180	213	257	257	283
Circuit B	A	-	-	-	-	180	213	213	257	283
Dissipated power⁽³⁾	A	3000	4200	4700	5300	6000	8400	8900	9400	10600

(1) Instantaneous start-up current.

(2) May vary, based on the short-circuit current/max. current draw ratio of the system transformer. Values obtained at operation with maximum unit power input.

(3) Values obtained at operation with maximum unit power input.

(4) Values obtained at operation with maximum unit power input. Values given on the unit name plate.

* Eurovent unit operating conditions: evaporator entering/leaving water temperature = 12°C/7°C, condenser entering/leaving water temperature = 30°C/35°C. Gross performances, not in accordance with EN14511-3:2013. These performances do not take into account the correction for the proportional heating capacity and power input generated by the water pump to overcome the internal pressure drop in the heat exchanger.

4 - PHYSICAL AND ELECTRICAL DATA

4.3 - Short-circuit stability current

	451	501	601	651	851	1001	1101	1201	1301
Value with unspecified upstream protection									
Short-term current at 1s-lcw-kA rms	5,0	6,0	6,0	6,0	5,0	6,0	6,0	6,0	6,0
Admissible peak current - I _{pk} -kA pk	7,1	8,5	8,5	8,5	7,1	8,5	8,5	8,5	8,5
Max. value with upstream protection (circuit breaker)									
Conditional short-circuit current I _{cc} -kA rms	50	50	50	50	50	50	50	50	50
Reference number ⁽¹⁾	NSX400-630-	NSX630-	NSX630-	NSX630-	NSX400-630-	NSX630-	NSX630-	NSX630-	NSX630-

(1) Earthing system type

(2) If another current limitation protection system is used, its time-current and thermal constraints (I²t) trip characteristics must be at least equivalent to those of the recommended Schneider circuit breaker.

The short circuit stability current values above are suitable with TN system.

4.4 - Compressor electrical data

Compressor nominal voltage/frequency: 380V/60Hz

Compressor	I Nom (A) ⁽¹⁾	I Max (A) ⁽²⁾	MHA (A)	LRDA (A)	Cosine phi nom ⁽¹⁾	Cosine phi max ⁽²⁾
06TUX483	134	227	240	1537	0,88	0,90
06TUX554	154	265	280	1537	0,88	0,90
06TVX680	184	304	322	2179	0,88	0,90
06TVX753	195	336	356	2179	0,88	0,90

(1) Value at standard Eurovent conditions: evaporator entering/leaving water temperature 12°C/7°C, condenser entering/leaving water temperature 30°C/35°C.

(2) Value at maximum capacity and nominal voltage.

Legend

MHA - Maximum compressor operating current, limited by the unit (current given for maximum capacity at 342 V)

LRDA - Locked rotor current for delta connection

4.5 - Compressor usage per circuit (A, B)

30XW-VZE/30XWHVZE	451	501	601	651	851	1001	1101	1201	1301
06TUX483	A	-	-	-	AB	-	-	-	-
06TUX554	-	A	-	-	-	AB	B	-	-
06TVX680	-	-	A	-	-	-	A	AB	-
06TVX753	-	-	-	A	-	-	-	-	AB

4 - PHYSICAL AND ELECTRICAL DATA

Electrical data notes and operating conditions, 30XW-VZE / 30XWHVZE units

- The unit has one connection point per circuit.
- The main switch disconnecter and the main short circuit protection are not included in the electrical cabinet.
- Field connections: All connections to the system and the electrical installations must be in full accordance with all applicable codes.
- The unit is designed and built to ensure conformance with local codes. The recommendations of European standard EN 60204-1 (corresponds to IEC 60204-1) (machine safety - electrical machine components - part 1: general regulations) are specifically taken into account, when designing the electrical equipment⁽¹⁾.
- The absence of the main disconnect switch is an exception that shall be considered at the building installation level.
- Compliance of the installation to 1999/92/CE directive on minimum requirements for improving the safety and health protection of workers potentially at risk from explosive atmospheres: The electrical equipment is not designed for compliance to 2014/34/EU directive for equipment and protective systems intended for use in potentially explosive atmospheres. The compliance of the building installation with article 3 Prevention of and protection against explosions shall be achieved by all necessary measures in the installation for prevention of the formation of explosive atmospheres
- Annex B of EN 60204 1 describes the electrical characteristics used for the operation of the machines. The ones described below apply to 30XW-VZE / 30XWHVZE units and complement other information in this document:
The operating environment for the units is specified below:
 1. Environment as classified in EN 60721 (corresponds to IEC 60721)⁽²⁾:
 - indoor installation
 - ambient temperature range: minimum temperature +5°C to +42°C, class AA4
 - altitude: lower than or equal to 2000 m
 - presence of water: class AD2 (possibility of water droplets)
 - presence of hard solids, class 4S2 (no significant dust present)
 - presence of corrosive and polluting substances, class 4C2 (negligible)
 2. Power supply frequency variation: ± 2 Hz.
 3. The neutral (N) line must not be connected directly to the unit (if necessary use a transformer).
 4. Overcurrent protection of the power supply conductors is not provided with the unit.

5. The unit is designed for connection to TN systems (IEC 60364). For IT systems the earth connection must not be at the network earth. Provide a local earth, consult competent local organisations to complete the electrical installation.
6. Electromagnetic environment: classification of the electromagnetic environment is described in standard EN 61800-3 (corresponds to IEC 61800-3):
 - Immunity to external interference defined by the second environment⁽³⁾
 - Interference emission as defined in category C3*
- Due to the harmonic currents the integrated frequency variator in the unit is a source of interference. An analysis may be required to verify if these interferences exceed the compatibility limits of the other devices connected to the same power supply network. The compatibility levels inside an electrical installation, that must be met at the in-plant coupling point (IPC) to which other loads are connected are described in standard 61000-2-4. Two characteristics are required for this analysis:
 - The short-circuit ratio (Rsce) of the installation calculated at the in-plant coupling point (IPC).
 - The total harmonic current distortion rate (THDI), calculated for the machine at maximum capacity.
- Derived currents: If protection by monitoring the leakage currents is necessary to ensure the safety of the installation, the presence of derived currents introduced by the use of frequency variators in the unit must be considered. In particular the reinforced immunity protection types and a control value not lower than 150 mA are recommended to control differential protection devices.

NOTE: If particular aspects of an actual installation do not conform to the conditions described above, or if there are other conditions which should be considered, always contact your local Carrier representative.

- (1) Generally the recommendations of IEC 60364 are accepted as compliance with the requirements of the installation directives. Conformance with EN 60204-1 is the best means of ensuring compliance with the Machinery Directive.
 - (2) The required protection level for this class is IP21B or IPX1B (according to reference document IEC 60529). All 30XW-VZE/30XWHVZE have IP23 units fulfil this protection condition.
 - (3) Example of installations of the second environment: industrial zones, technical locations supplied from a dedicated transformer.
- * Category C3 is suitable for use in an industrial environment and is not designed for use in a public low-voltage system that supplies residential locations. As an option, conformity with category C2 permits this type of installation.

5 - ELECTRICAL CONNECTION

Please refer to the certified dimensional drawings, supplied with the unit.

5.1 - Power supply

The power supply must conform to the specification on the unit nameplate. The supply voltage must be within the range specified in the electrical data table. For connection details refer to the wiring diagrams.

WARNING: Operation of the unit with an improper supply voltage or excessive phase imbalance constitutes abuse which will invalidate the Carrier warranty. If the phase imbalance exceeds 2% for voltage, or 10% for current, contact your local electricity supplier at once and ensure that the unit is not switched on until corrective measures have been taken.

5.2 - Voltage phase imbalance (%)

$$\frac{100 \times \text{max. deviation from average voltage}}{\text{Average voltage}}$$

Example:

On a 400 V - 3 ph - 50 Hz supply, the individual phase voltages were measured to be:

AB = 406 V; BC = 399 V; AC = 394 V

Average voltage = $(406 + 399 + 394)/3 = 1199/3 = 399.7$ say 400 V

Calculate the maximum deviation from the 400 V average:

The maximum deviation from the average is 6 V. The greatest percentage deviation is: $100 \times 6/400 = 1.5\%$. This is less than the permissible 2% and is therefore acceptable.

(AB)	= 406 - 400	= 6
(BC)	= 400 - 399	= 1
(A)	= 400 - 394	= 6

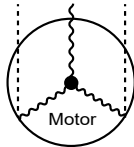

5.3 - Power connection

Units with one compressor have one connection point

Units with two compressors have two connection pointst

5.4 - Recommended wire sections

Wire sizing is the responsibility of the installer, and depends on the characteristics and regulations applicable to each installation site. The following is only to be used as a guideline, and does not make in any way liable. After wire sizing has been completed, using the certified dimensional drawing, the installer must ensure easy connection and define any modifications necessary on site. The maximum connectable wire section is 2x240mm² per phase.

5.5 - Power cable entry

The power cables can enter the unit control box from above the unit. A removable aluminium plate on the upper part of the control box face allows introduction of the cables. Refer to the certified dimensional drawing for the unit.

5.6 - Field control wiring

IMPORTANT: Field connection of interface circuits may lead to safety risks: any control box modification must maintain equipment conformity with local regulations. Precautions must be taken to prevent accidental electrical contact between circuits supplied by different sources:

- The routing selection and/or conductor insulation characteristics must ensure dual electric insulation.
- In case of accidental disconnection, conductor fixing between different conductors and/or in the control box prevents any contact between the conductor ends and an active energised part.

Refer to the SmartVu™ Control manual and the certified wiring diagram supplied with the unit for the field control wiring of the following features:

- Customer interlock
- Remote on/off switch
- Demand limit external switch
- Remote dual set point
- Alarm, alert and operation report
- Evaporator pump control
- Condenser pump control signal (This does not control condenser pump operation (for this function add option 156 and flow switch).
- Heating/cooling change-over
- Refrigerant leak detection
- Water valve control (option)
- Various interlocks and reports on the Energy Management Module board (option)

CCN bus connection

- The permanent connection to the system CCN bus is made at the terminal provided for this purpose inside the control box.
- The connection of the CCN service tool is possible at a socket under the control box, accessible from outside.

5.7 - 24 and 230 V power reserve for the user

Control circuit reserve:

After all required options have been connected, the TC transformer includes a power reserve of 1 A at 24 V a.c. that can be used for the field control wiring.

A second TCA transformer supplies the 230 V, 50 Hz circuit to charge a battery for a portable computer at 0.63 A maximum at 230 V. The connection is via an EEC 7/16 type socket (2 poles without earth) located on the inside front of the control box and accessible from outside.

Only devices with class II double insulation can be connected at this socket.

6 - APPLICATION DATA

6.1 - 30XW-VZE /30XWHVZE Operating limits

30XW-V/30XWHV	Minimum	Maximum
Evaporator		
Entering temperature at start-up	-	35,0°C
Leaving temperature during operation	3,3°C ⁽¹⁾	20,0°C
Entering/leaving temperature difference at full load	2,8 K	11,1 K
Condenser		
Entering temperature at start-up	13,0°C ⁽²⁾	-
Leaving temperature during operation	19,0°C ⁽²⁾	55,0°C
Entering/leaving temperature difference at full load	2,8 K	11,1 K

- (1) For low-temperature applications, where the leaving water temperature is below 3.3°C, a frost protection solution must be used. Please refer to option 8
 (2) For lower condenser temperatures a water flow control valve must be used at the condenser (two or three-way valve). Please refer to option 152 to ensure the correct condensing temperature.

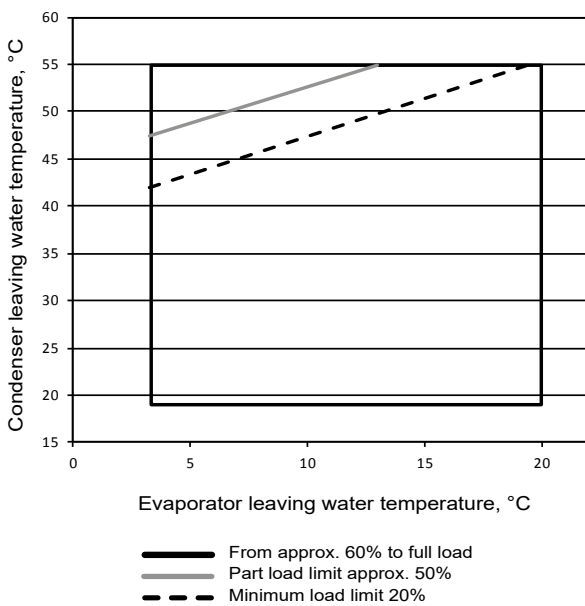

Note: Ambient temperatures: These units are dedicated for indoor environment. The external temperature at chiller start up should be at least 5°C. For such low ambient, option 152 is recommended. During storage and transport of the 30XW-VZE/30XWHVZE units (including by container) the minimum and maximum permissible temperatures are -20°C and 70°C.

6.2 - Condenser-side installation recommendation

To ensure unit start-up at low condenser water temperature conditions, a specific installation may be necessary. Please refer to the table below:

	0 < t < 20min	20 < t < 40min	40 < t < 60min	t > 60min
15°C < x	①			②
13 < x < 15°C	①			②
11 < x < 13°C		③		④
8 < x < 11°C				④
x < 8°C				④

- x Condenser water temperature before start-up
 t Time required to reach a temperature of 19°C at the condenser outlet
 1 "The unit can start without the use of a two- or three-way valve, but operation will be more reliable with the control valve."
 2 "The use of a two- or three-way valve is strongly recommended."
 3 "The use of a two- or three-way valve is compulsory."
 4 The use of a two- or three-way valve is compulsory and the use of variable speed pumps is strongly recommended.

6.3 - Minimum chilled water flow

The minimum chilled water flow is shown in the table in chapter 7.7.

If the system flow is less than the minimum unit flow rate, the evaporator flow can be recirculated, as shown in the diagram.

For minimum chiller flow rate

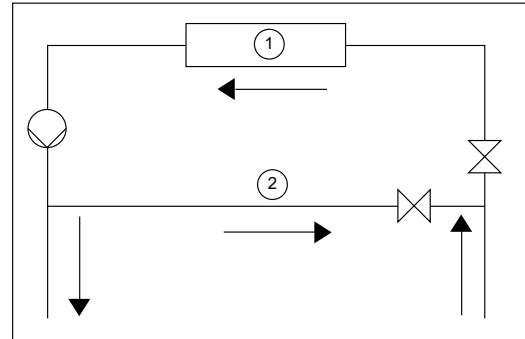

Legend

- 1 Evaporator
 2 Recirculation

6.4 - Maximum chilled water flow

The maximum chilled water flow is limited by the permitted pressure drop in the evaporator. It is provided in the table in chapter 7.7.

- Select the option with one water pass less that will allow a higher maximum water flow rate (see option 100C in the table in chapter 6.6 "Number of passes").
- Bypass the evaporator as shown in the diagram to obtain a lower evaporator flow rate.

For maximum chiller flow rate

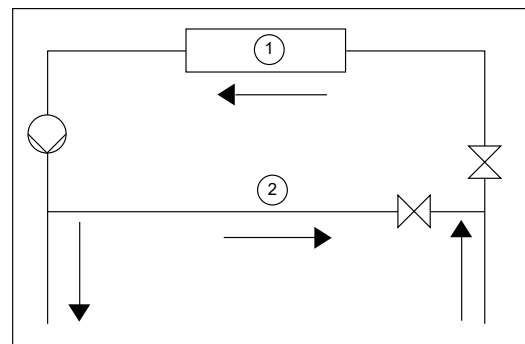

Legend

- 1 Evaporator
 2 Bypass

6.5 - Condenser water flow rate

The minimum and maximum condenser water flow rates are shown in the table in chapter 7.7 "Evaporator and condenser water flow rates".

If the system flow is higher than the maximum unit flow rate, select the option with one pass less that will allow a higher maximum water flow rate. Please refer to option 102C in the table in chapter 7.6 "Number of passes".

6 - APPLICATION DATA

6.6 - Standard and optional number of water passes

30XW-VZE/30XWHVZE	451	501	601	651	851	1001	1101	1201	1301
Evaporator									
Standard	2	2	2	2	2	2	2	2	2
Option 100C	1	1	1	1	1	1	1	1	1
Condenser									
Standard	2	2	2	2	2	2	2	2	2
Option 102C	1	1	1	1	1	1	1	1	1

6.7 - Evaporator and condenser water flow rates

These below values are given for standard units. For options 100C and 102C, please refer to the unit selection program.

30XW-V/30XWHV	451	501	601	651	851	1001	1101	1201	1301
Evaporator water flow rate, l/s									
Minimum	6	6	8	8	15	15	15	15	15
Maximum	54	54	76	76	170	170	170	170	170
Condenser water flow rate, l/s									
Minimum	6	6	8	8	15	15	15	15	15
Maximum	52	52	74	74	170	170	170	170	170

Notes

- Minimum evaporator flow rate based on a water velocity of 0,3 m/s.
- Minimum condenser flow rate based on a water velocity of 0,3 m/s.

6.8 - Variable flow evaporator

Variable evaporator flow can be used. The pump drive can be managed by unit control (0/10V output on terminal 90+ / 90-). The controlled flow rate must be higher than the minimum flow given in the table of permissible flow rates and must not vary by more than 10% per minute.

If the flow rate changes more rapidly, the system should contain a minimum of 6.5 liters of water per kW instead of 3.25 l/kW.

6.9 - System minimum water volume

Whichever the system, the water loop minimum volume is given by the formula:

$$\text{Volume} = \text{Cap (kW)} \times \text{N litres}$$

Application	N
Normal air conditioning	3,25
Process type cooling	6,5

Where Cap is the nominal system cooling capacity (kW) at the nominal operating conditions of the installation.

This volume is necessary for stable operation. It is often necessary to add a buffer water tank to the circuit in order to achieve the required volume. The tank must itself be internally baffled in order to ensure proper mixing of the liquid (water or brine). Refer to the examples below.

Conection to buffer tank

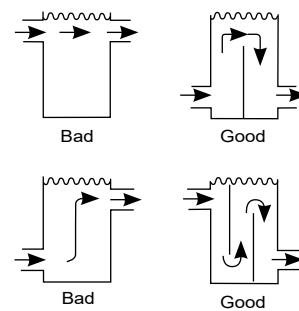

6 - APPLICATION DATA

6.10 - Evaporator pressure drop curves

Units with two evaporator passes (standard)

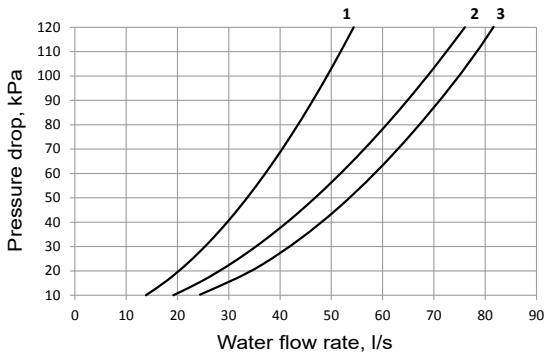

Legend

- 1 451, 501
- 2 601, 651
- 3 851, 1001, 1101, 1201, 1301

Units with one evaporator pass (option 100C)

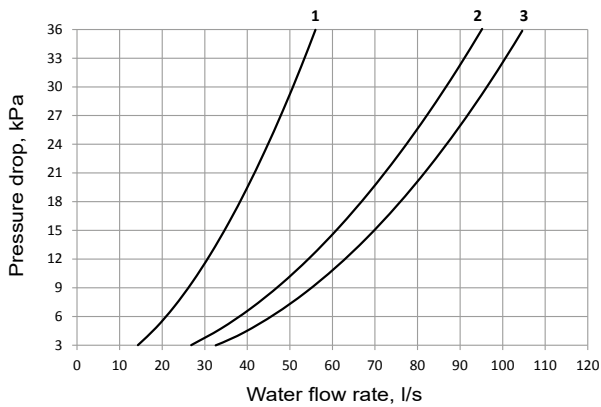

Legend

- 1 451, 501
- 2 601, 651
- 3 851, 1001, 1101, 1201, 1301

6.11 - Condenser pressure drop curves

Units with two condenser passes (standard)

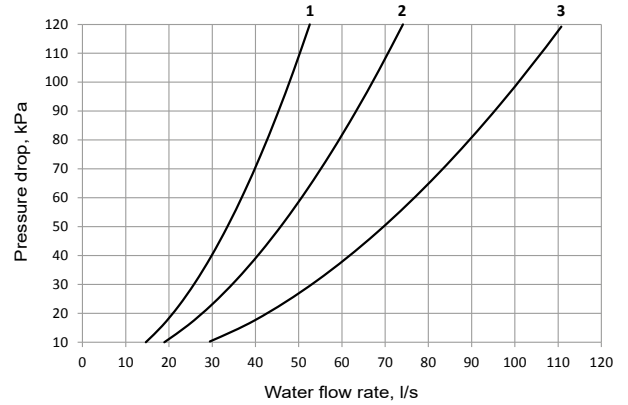

Units with one condenser pass (option 102C)

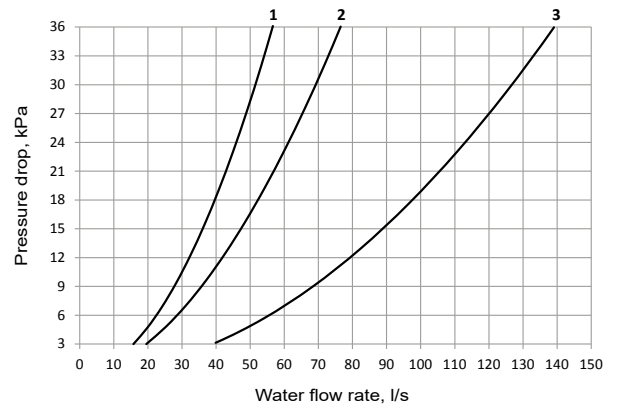

Legend

- 1 451, 501
- 2 601, 651
- 3 851, 1001, 1101, 1201, 1301

7 - WATER CONNECTIONS

ATTENTION: Before carrying out any water connections install the water box purge plugs (one plug per water box in the lower section supplied in the control box).

For size and position of the heat exchanger water inlet and outlet connections refer to the certified dimensional drawings supplied with the unit.

The water pipes must not transmit any radial or axial force to the heat exchangers nor any vibration.

The water supply must be analysed and appropriate filtering, treatment, control devices, isolation and bleed valves and circuits built in, to prevent corrosion, fouling and deterioration of the pump fittings. Consult either a water treatment specialist or appropriate literature on the subject

7.1 - Operating precautions

The water circuit should be designed to have the least number of elbows and horizontal pipe runs at different levels. Below the main points to be checked for the connection:

- Comply with the water inlet and outlet connections shown on the unit.
- Install manual or automatic air purge valves at all high points in the circuit(s).
- Use a pressure reducer to maintain pressure in the circuit(s) and install a relief valve as well as an expansion tank.
- Install thermometers in both the entering and leaving water connections.
- Install drain connections at all low points to allow the whole circuit to be drained.
- Install stop valves, close to the entering and leaving water connections.
- Use flexible connections to reduce the transmission of vibrations.
- Insulate all pipework, after testing for leaks, both to reduce heat gains and to prevent condensation.
- Cover the insulation with a vapour barrier
- If there are particles in the fluid that could foul the heat exchanger, a screen filter should be installed ahead of the pump. The mesh size of the filter must be 1.2 mm.
- Before the system start-up verify that the water circuits are connected to the appropriate heat exchangers (e.g. no reversal between evaporator and condenser).
- Do not introduce any significant static or dynamic pressure into the heat exchange circuit (with regard to the design operating pressures).
- Before any start-up verify that the heat exchange fluid is compatible with the materials and the water circuit coating.
- The use of different metals on hydraulic piping could generate electrolytic pairs and consequently corrosion. It could be needed to add sacrificial anodes.
- In case additives or other fluids than those recommended by Carrier are used, ensure that the fluids are not considered as a gas, and that they belong to class 2, as defined in directive 97/23/EC.

Carrier recommendations on heat exchange fluids:

- No NH₄⁺ ammonium ions in the water, they are very detrimental for copper. This is one of the most important factors for the operating life of copper piping. A content of several tenths of mg/l will badly corrode the copper over time.
- Cl⁻ Chloride ions are detrimental for copper with a risk of perforations by corrosion by puncture. If possible keep below 125 mg/l.
- SO₄²⁻ sulphate ions can cause perforating corrosion, if their content is above 30 mg/l.
- No fluoride ions (<0.1 mg/l).
- No Fe²⁺ and Fe³⁺ ions with non negligible levels of dissolved oxygen must be present. Dissolved iron < 5 mg/l with dissolved oxygen < 5 mg/l.
- Dissolved silica: silica is an acid element of water and can also lead to corrosion risks. Content < 1 mg/l.
- Water hardness: > 0.5 mmol/l. Values between 1 and 2.5 can be recommended. This will facilitate scale deposit that can limit corrosion of copper. Values that are too high can cause piping blockage over time. A total alkalimetric titre (TAC) below 100 mg/l is desirable.
- Dissolved oxygen: Any sudden change in water oxygenation conditions must be avoided. It is as detrimental to deoxygenate the water by mixing it with inert gas as it is to over-oxygenate it by mixing it with pure oxygen. The disturbance of the oxygenation conditions encourages destabilisation of copper hydroxides and enlargement of particles.
- Electric conductivity 10-600µS/cm.
- pH: Ideal case pH neutral at 20-25°C 7 < pH < 8

When the water circuit must be emptied for longer than one month or immediately if the water does not comply with the above description, the circuit must be either totally dried or placed under 0.5 bar maximum nitrogen charge. This is done to avoid any damage of the exchanger copper tubes with corrosion by differential aeration. In case of nitrogen charge, the circuit must be equipped with relief valves to avoid overpressure due to refrigerant leakage.

CAUTION: Filling, completing and draining the water circuit charge must be done by qualified personnel, using the air purges and materials that are suitable for the products.

Charging and removing heat exchange fluids should be done with devices that must be included on the water circuit by the installer. Never use the unit heat exchangers to add heat exchange fluid.

7 - WATER CONNECTIONS

7.2 - Water connections

The water connections are Victaulic type connections. The inlet and outlet connection diameters are identical.

Inlet/outlet diameters

Evaporator 30XW-V/30XWHV		451	501	601	651	851	1001	1101	1201	1301
Units without option 100C										
Connection	in	6	6	8	8	8	8	8	8	8
Outside diameter	mm	168,3	168,3	219,1	219,1	219,1	219,1	219,1	219,1	219,1
Units with option 100C										
Connection	in	6	6	8	8	8	8	8	8	8
Outside diameter	mm	168,3	168,3	219,1	219,1	219,1	219,1	219,1	219,1	219,1
Condenser 30XW-V/30XWHV										
		451	501	601	651	851	1001	1101	1201	1301
Units without option 102C										
Connection	in	6	6	8	8	8	8	8	8	8
Outside diameter	mm	168,3	168,3	219,1	219,1	219,1	219,1	219,1	219,1	219,1
Units with option 102C										
Connection	in	8	8	8	8	8	8	8	8	8
Outside diameter	mm	219,1	219,1	219,1	219,1	219,1	219,1	219,1	219,1	219,1

7.3 - Flow control

Evaporator flow switch and chilled water pump interlock

IMPORTANT: The unit water flow switch must be energised, and the chilled water pump interlock must be connected. Failure to follow this instruction will void the Carrier guarantee.

The water flow switch is installed on the evaporator water inlet and adjusted by the control. If adjustment is necessary, it must be carried out by qualified personnel trained by Carrier Service.

7.4 - Evaporator and condenser water box bolt tightening

The evaporator (and condenser) are of the shell and tube type with removable water boxes to facilitate cleaning. Re-tightening or tightening must be done in accordance with the illustration in the example below.

NOTE: Before this operation we recommend draining the circuit and disconnecting the pipes to be sure that the bolts are correctly and uniformly tightened

Water box tightening sequence

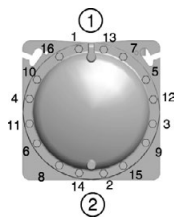

Legend

- 1 Sequence 1: 1 2 3 4
Sequence 2: 5 6 7 8
Sequence 3: 9 10 11 12
Sequence 4: 13 14 15 16
- 2 Tightening torque
Bolt size M 16 - 171 - 210 Nm

7.5 - Operation of two units in master/slave mode

The control of a master/slave assembly is in the entering water and does not require any additional sensors (standard configuration). It can also be located in the leaving water. In this case two additional sensors must be added on the common piping.

All parameters, required for the master/slave function must be configured using the MST_SLV menu.

All remote controls of the master/slave assembly (start/ stop, set point, load shedding etc.) are controlled by the unit configured as master and must only be applied to the master unit.

Each unit controls its own water pump. If there is only one common pump, in cases with variable flow, isolation valves must be installed on each unit. They will be activated at the opening and closing by the control of each unit (in this case the valves are controlled using the dedicated water pump outputs). See the SmartVu™ Control IOM for a more detailed explanation.

Unit with configuration: leaving water control

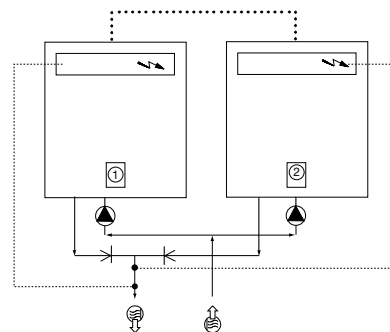

Legend

- ① → Master unit
- ② → Slave unit
- ⚡ → Control boxes of the master and slave units
- ↙ ↘ → Water inlet
- ↖ ↗ → Water outlet
- ⚙ → Water pumps for each unit (included as standard for units with hydraulic module)
- → Additional sensors for leaving water control, to be connected to channel 1 of the slave boards of each master and slave unit
- → CCN communication bus
- → Connection of two additional sensors

8 - HEAT PUMPS 30XWHVZE

8.1 - Physical data for heat pumps

The physical data for 30XWHVZE for heat pumps are the same as for the 30XW-VZE units. Please refer to chapter 5.1.

8.2 - Electrical data for heat pumps

The electrical data for 30XWHVZE for heat pumps are the same as for the 30XW-VZE units. Please refer to chapter 5.2.

8.3 - Dimensions and clearances for heat pumps

The dimensions and clearances are the same as for the 30XW-VZE units. Please refer to chapter 4.

8.4 - Operating range for heat pumps

The operating limits are the same as for the 30XW-VZE units. Please refer to chapter 7.1.

8.5 - Operating modes for heat pumps

8.5.1 - Cooling mode

This operating mode is the same as that for 30XW-VZE units. The unit controls on the cooling setpoint.

8.5.2 - Heating mode

Unlike in the cooling mode, the unit uses the heating setpoint in this configuration. The evaporator leaving water control (lowest setpoint taken into consideration) is still maintained to prevent operation at very low temperatures.

9 - MAJOR SYSTEM COMPONENTS AND OPERATION DATA

9.1 - Compressor

- 30XW-VZE/30XWHVZE units use 06T geared twin-screw compressors equipped with a variable capacity slide valve and controlled by a speed variator.
- Compressor capacity control is ensured by successive use of speed variation (using a frequency variator) and swept volume variation at the screws (using the slide valve).
- The combination of these two control modes permits fine control of the unit capacity between 20% and 100%.
- The 06T compressor models used are: 06TUX483, 06TUX554, 06TVX680, 06TVX753

9.2 - Oil filter

The 06T screw compressor has an independent oil filter.

9.3 - Refrigerant

The unit is a liquid chiller operating with refrigerant R1234ze(E) (standard) or R515B (option 330).

9.4 - Lubricant

The 06T screw compressor is approved for use with the following lubricant: CARRIER MATERIAL SPEC PP 47-38.

9.5 - Oil supply solenoid valve

An oil supply solenoid valve is installed on the oil return line as standard to isolate the compressor from oil flow when the compressor is not operating. The oil solenoid valve is field replaceable.

9.6 - Pressure vessels

General

Monitoring during operation, re-qualification, re-testing and re-testing dispensation:

- Follow the regulations on monitoring pressurised equipment.
- It is normally required that the user or operator sets up and maintains a monitoring and maintenance file.
- If no regulations exist or to complement regulations, follow the control programs of EN 378.
- If they exist follow local professional recommendations.
- Regularly inspect the condition of the coating (paint) to detect blistering resulting from corrosion. To do this, check a non-insulated section of the container or the rust formation at the insulation joints.
- Regularly check for possible presence of impurities (e.g. silica grains) in the heat exchange fluids. These impurities may be the cause of the wear or corrosion by puncture.
- Filter the heat exchange fluid. Check and carry out internal inspections as described in EN 378, annex C.
- In case of re-testing please refer to the maximum operating pressure given on the unit nameplate.
- The reports of periodical checks by the user or operator must be included in the supervision and maintenance file.
- Filter the coolant and carry out internal inspections as described in EN 378.
- In case of re-testing please refer to the maximum operating pressure given on the unit nameplate.
- The reports of periodical checks by the user or operator must be included in the supervision and maintenance file.

Repair

Any repair or modification, including the replacement of moving parts:

- must follow local regulations and be made by qualified operators and in accordance with qualified procedures, including changing the heat exchanger tubes.
- must be made in accordance with the instructions of the original manufacturer. Repair and modification that necessitate permanent assembly (soldering, welding, expanding etc.) must be made using the correct procedures and by qualified operators.
- An indication of any modification or repair must be shown in the monitoring and maintenance file.

Recycling

The unit is wholly or partly recyclable. After use it contains refrigerant vapours and oil residue. It is coated by paint.

Operating life

The evaporator and oil separator are designed for:

- prolonged storage of 15 years under nitrogen charge with a temperature difference of 20K per day.
- 452000 cycles (start-ups) with a maximum difference of 6 K between two neighbouring points in the vessel, based on 6 start-ups per hour over 15 years at a usage rate of 57%.

Corrosion allowances

Gas side: 0 mm

Heat exchange fluid side: 1 mm for tubular plates in lightly alloyed steels, 0 mm for stainless steel plates or plates with copper-nickel or stainless steel protection.

9 - MAJOR SYSTEM COMPONENTS AND OPERATION DATA

Evaporator

30XW-VZE/30XWHVZE chillers use a flooded multi-tube evaporator. The water circulates in the tubes and the refrigerant is on the outside in the shell. One vessel is used to serve both refrigerant circuits. There is a center tube sheet which separates the two refrigerant circuits. The tubes are 3/4" diameter copper with an enhanced surface inside and out. There is just one water circuit with two water passes.

The evaporator shell has a polyurethane foam thermal insulation and a water drain and purge.

It has been tested and stamped in accordance with the applicable pressure codes. The maximum standard relative operating pressure is 2100 kPa for the refrigerant side and 1000 kPa for the water-side. These pressures can be different depending on the code applied. The water connection of the heat exchanger is a Victaulic connection.

The products that may be added for thermal insulation of the containers during the water piping connection procedure must be chemically neutral in relation to the materials and coatings to which they are applied. This is also the case for the products originally supplied by Carrier.

Condenser and oil separator

The 30XW-VZE/30XWHVZE chiller uses a heat exchanger that is a combination condenser and oil separator. It is mounted below the evaporator. Discharge gas leaves the compressor and flows through an external muffler to the oil separator, which is the upper portion of the heat exchanger. It enters the top of the separator where oil is removed, and then flows to the bottom portion of the vessel, where gas is condensed and subcooled. One vessel is used to serve both refrigerant circuits. There is a center tube sheet which separates the two refrigerant circuits. The tubes are 3/4" or 1" diameter internally and externally finned copper tubes.

There is just one water circuit with two water passes. For the Heat Machine units the condenser shell can have a polyurethane foam thermal insulation (option 86) and a water drain and purge.

It has been tested and stamped in accordance with applicable pressure codes. The maximum standard relative operating pressure is 2100 kPa for the refrigerant side and 1000 kPa for the water-side. These pressures can be different depending on the code applied. The water connection of the heat exchanger is a Victaulic connection.

9.7 - High Pressure SRMCR safety loop

9.7.1 - General description

The unit is equipped with a high pressure safety loop, known as the SRMCR (Safety-Related Measurement Control and Regulation) loop, comprising

- 2 high pressure switches (HPS) that require resetting with a tool at the outlet for each compressor called PZHH
- The speed regulator which supplies the compressor is equipped with the Safe Torque Off (STO) function.

Refer to the wiring diagram and the nomenclature for the machine (references).

This SRMCR device is designed in accordance with standard EN 61508 for SIL (safety integrity level): 2.

Demand mode: bottom and top.

The mission time is 20 years.

Periodic testing: the test must be performed at least once a year during the normal periodic pressure test. Refer to the description in section 11.9.

9.7.2 - Description of operation and resetting

The image below is intended to illustrate the operating description: refer to the detailed machine drawing for the precise wiring diagram.

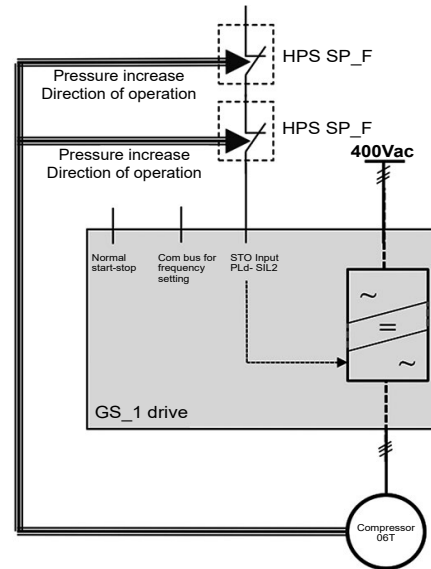

HPS : High pressure switch SP1F(A)/SP2F(A)
GS_1 : Power drive for compressor GSA1/GSB1

During normal operation, the speed regulator supplies and controls the compressor once the control signal is received via the digital on-off input (normal on-off) and the communication bus (setting the frequency).

When one of the HPS sensors opens, the STO (Safe Torque Off) digital input opens, which instantly suppresses the control command for the thyristors which manage the supply for the compressor, independently of the on-off commands and frequencies: the compressor is no longer supplied and stops immediately.

9.7.3 - Verification in case of a safety device failure

If the unit operating pressure appears to have been exceeded at some point (for example, after the relief valves have been opened), the unit must be stopped immediately.

The safety loop unit must pass all the periodic verifications before any restart is possible.

If the test reveals malfunctions likely to have caused overpressure within the machine, a complete check of all the pressure equipment must be performed to check their mechanical integrity.

9.7.4 - Restarting after high pressure is detected

After overpressure is detected, it is necessary to manually reset the switched HPS. A blunt tool with a diameter of less than 6 mm must be used for this.

10 - OPTIONS AND ACCESSORIES

Options	N°	Description	Advantages	Use for 30XW-VZE range
Light-brine solution, down to -3°C	8	Implementation of new algorithms of control to allow chilled brine solution production down to -3°C when ethylene glycol is used (0°C with propylene glycol)	Matches with most application requirements for ground-sourced heat pumps and fits with many industrial processes requirements	451-1301 (see dedicated paragraph)
Master/slave operation	58	Unit equipped with supplementary water outlet temperature sensor kit to be field-installed allowing master/slave operation of two units connected in parallel	Optimised operation of two units connected in parallel operation with operating time equalisation	451-1301
Condenser insulation	86	Thermal condenser insulation	Minimizes thermal dispersions condenser side (key option for heat pump or heat recovery applications) and allows compliancy with special installation criteria (hot parts insulated)	451-1301
Service valve set	92	Liquid line valve (evaporator inlet) and compressor suction line valve	Allow isolation of various refrigerant circuit components for simplified service and maintenance	451-1301
Evaporator with one pass less	100C	Evaporator with one pass on the water side. Evaporator inlet and outlet on opposite sides.	Easy to install, depending on site. Reduced pressure drops	451-1301
Condenser with one pass less	102C	Condenser with one pass on the water side. Condenser inlet and outlet on opposite sides.	Easy to install, depending on site. Reduced pressure drops	451-1301
21 bar evaporator	104	Reinforced evaporator for extension of the maximum water-side service pressure to 21 bar (standard 10 bar)	Covers applications with a high water column evaporator side (typically high buildings)	451-1301
21 bar condenser	104A	Reinforced condenser for extension of the maximum water-side service pressure to 21 bar (standard 10 bar)	Covers applications with a high water column condenser side (typically high buildings)	451-1301
Reversed evaporator water connections	107	Evaporator with reversed water inlet/outlet	Easy installation on sites with specific requirements	451-1301
Reversed condenser water connections	107A	Condenser with reversed water inlet/outlet	Easy installation on sites with specific requirements	451-1301
Lon gateway	148D	Two-directional communication board complying with Lon Talk protocol	Connects the unit by communication bus to a building management system	451-1301
Bacnet over IP	149	Two-directional high-speed communication using BACnet protocol over Ethernet network (IP)	Easy and high-speed connection by ethernet line to a building management system. Allows access to multiple unit parameters	451-1301
Modbus over IP and RS485	149B	Bi-directional high-speed communication using Modbus protocol over Ethernet network (IP)	Easy and high-speed connection by ethernet line to a building management system. Allows access to multiple unit parameters	451-1301
Condensing temperature limitation	150B	Limitation of the maximum condenser leaving water temperature to 45°C	Reduced maximum power input and current absorption: power cables and protection elements can therefore be downsized	451-1301
Control for low cond. temperature systems	152	Output signal (0-10 V) to control the condenser water inlet valve	Simple installation: for applications with cold water at condenser inlet (ex. ground-source, groundwater-source, superficial water-source applications) the signal permits to control a 2 or 3-way valve to maintain condenser water temperature (and so condensing pressure) at acceptable values	451-1301
Energy Management Module	156	EMM Control board with additional inputs/outputs. See Energy Management Module option chapter	Extended remote control capabilities (Set-point reset, ice storage end, demand limits, boiler on/off command...)	451-1301
Compliance with Swiss regulations	197	Additional tests on the water heat exchangers: supply (additional of PED documents) supplementary certificates and test certifications	Conformance with Swiss regulations	451-1301
Compliance with Australian regulations	200	Unit approved to Australian code	Conformance with Australian regulations	451-1301
Low noise level	257	Evaporator sound insulation	3 dB(A) quieter than standard unit	451-1301
Welded evaporator connection kit	266	Victaulic piping connections with welded joints	Easy installation	451-1301
Welded condenser water connection kit	267	Victaulic piping connections with welded joints	Easy installation	451-1301

10 - OPTIONS AND ACCESSORIES

Options	N°	Description	Advantages	Use for 30XW-VZE range
Flanged evaporator water connection kit	268	Victaulic piping connections with flanged joints	Easy installation	451-1301
Flanged condenser water connection kit	269	Victaulic piping connections with flanged joints	Easy installation	451-1301
Thermal compressor insulation	271	The compressor is covered with a thermal insulation layer	Prevents air humidity to condensate on the compressor surface	451-1301
EMC classification C2, as per EN 61800-3	282	Additional RFI filters on the unit power line	Reduces electromagnetic interferences for compliance with emission level category C2 in order to allow the units to operate in the first environment (so called, residential environment)	451-1301
Fast Capacity Recovery	QM295	New software algorithms to allow quick restart and fast loading while preserving unit-reliability	Full capacity recovery in less than 5 minutes after power failure. Matches requirements of typical critical missions applications	451-1301
Carrier Connect link (BSS regions only)	298	3G router board NOTE 1: require option 149 NOTE 2: when more than one machine is installed on site, only one of them shall be equipped with option 298 while all of them must be equipped with option 149 NOTE 3: if the Carrier® PlantCTRL™ is on site, option 298 shall be integrated in the Carrier® PlantCTRL™ while option 149 is still mandatory for each single unit.	Enabler for Carrier Connect service offer	451-1301
Low GWP A1 R-515B refrigerant	330	Unit delivered with R-515B refrigerant charge (A1, GWP 299)	Reduced CO ₂ footprint (GWP < 300) A1 safety class Reduced installed cost in technical room	451-1301

11 - STANDARD MAINTENANCE

Air conditioning equipment must be maintained by professional technicians, whilst routine checks can be carried out locally by specialised technicians. See the standard EN 378-4.

Simple preventive maintenance will allow you to get the best performance from your HVAC unit:

- improved cooling performance
- reduced power consumption
- prevention of accidental component failure
- prevention of major time consuming and costly interventions
- protection of the environment

There are five maintenance levels for HVAC units, as defined by the AFNOR X60-010 standard.

11.1 - Level 1 maintenance

See note below.

Simple procedure can be carried out by the user:

- Visual inspection for oil traces (sign of a refrigerant leak)
- Check for removed protection devices, and badly closed doors/covers
- Check the unit alarm report when the unit does not work (see report in the SmartVu™ control manual).

General visual inspection for any signs of deterioration.

11.2 - Level 2 maintenance

This level requires specific know-how in the electrical, hydraulic and mechanical fields. It is possible that these skills are available locally: existence of a maintenance service, industrial site, specialised subcontractor.

In these cases, the following maintenance operations are recommended.

Carry out all level 1 operations, then:

- At least once a year tighten the power circuit electrical connections (see tightening torques table).
- Check and re-tighten all control/command connections, if required (see tightening torques table).
- Check the differential switches for correct operation every 6 months.
- Remove the dust and clean the interior of the control boxes, if required. Check the filter condition.
- Check the presence and the condition of the electrical protection devices.
- Replace the fuses every 3 years or every 15000 hours (age-hardening).
- Check the water connections.
- Purge the water circuit (see chapter 7 "Water connections")
- Clean the water filter (see chapter 7 "Water connections").
- Check the unit operating parameters and compare them with previous values.
- Keep and maintain a maintenance sheet, attached to each HVAC unit.

All these operations require strict observation of adequate safety measures: individual protection garments, compliance with all industry regulations, compliance with applicable local regulations and using common sense.

11.3 - Level 3 (or higher) maintenance

The maintenance at this level requires specific skills/ approval/ tools and know-how and only the manufacturer, his representative or authorised agent are permitted to carry out these operations. These maintenance operations concern for example:

- A major component replacement (compressor, evaporator)
- Any intervention on the refrigerant circuit (handling refrigerant)
- Changing of parameters set at the factory (application change)
- Removal or dismantling of the HVAC unit
- Any intervention due to a missed established maintenance operation
- Any intervention covered by the warranty

NOTE: Any deviation or non-observation of these maintenance criteria will render the guarantee conditions for the HVAC unit nul and void, and the manufacturer, Carrier France, will no longer be held responsible

11.4 - Tightening of the electrical connections

11.4.1 - Tightening torques for the main electrical connections

Screw type	Designation in the unit	Torque value, N·m
Customer connection		
Screw-nut M12 at phase decks	L1/L2/L3	50
Nut on earth terminal	PE	81
Downstream power connections in the control box		
Screw M10 at downstream main disconnect deck (QS10)*	L1/L2/L3	50
Earth terminal M10		50
Power connections in the variator		
M10 nut on the phase pin	GS-	19-40
M10 nut on the earth pin		19-40
Compressor phase connection terminals		
M12	1/2/3/4/5/6 on EC-	23
M16	1/2/3/4/5/6 on EC-	30
Compressor earth connection		
	Gnd on EC-	25
Control disconnect connections		
Upstream and downstream screws at terminals	QF	2

ATTENTION: The tightening of the connections at the compressor terminals requires special precautions. Please refer to the chapter below.

11 - STANDARD MAINTENANCE

11.4.2 - Connection precautions for the compressor power terminals

These precautions must be applied during an intervention that requires the removal of the power conductors connected to the compressor supply terminals.

The tightening nut of terminal (6) supporting the isolator (7) must never be loosened, as it ensures terminal tightness and compressor leak tightness.

The tightening of phase lug (4) must apply the torque between counter nut (5) and tightening nut (3): during this operation a counter-torque must be applied at counter nut (5). Counter-nut (5) must not be in contact with the tightening nut of terminal (6).

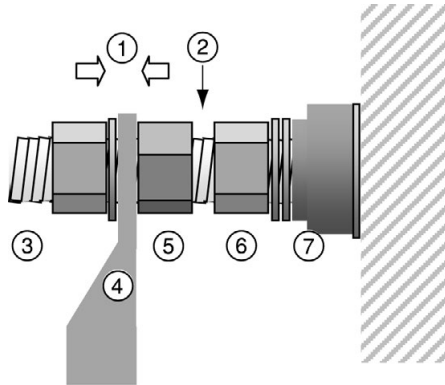

Legend

1. Torque application to tighten the lug
2. Avoid contact between the two nuts
3. Lug tightening nut
4. Flat lug
5. Counter-nut
6. Terminal tightening nut
7. Isolator

11.5 - Tightening torques for the main bolts and screws

Screw type	Used for	Torque value, N·m
M20 nut	Chassis	190
M20 nut	Heat exchanger side-side connection	240
M16 nut	Compressor fixing	190
H M16 screw	Heat exchanger water boxes, structure	190
H M16 screw	Compressor suction flanges	190
H M20 screw	Compressor suction flanges TU & TV	240
M16 nut	Compressor discharge line TU	190
M20 nut	Compressor discharge line TV	240
H M8 screw	Drier cover	35
1/8 NPT connection	Oil line	12
TE nut	Compressor oil line	24,5
7/8 ORFS nut	Oil line	130
5/8 ORFS nut	Oil line	65
3/8 ORFS nut	Oil line	26
H M6 screw	Stauff collar	10
Taptite screw M6	Oil line collar	7
Metric screw M6	Plate fixing, control box, terminal box	7
Taptite screw M10	Oil filter, control box fixing	30

ATTENTION: The tightening of the connections at the compressor terminals requires special precautions. Please refer to the chapter above.

11.6 - Evaporator and condenser maintenance

Check that:

- the insulating foam is intact and securely in place,
- the sensors and flow switch are correctly operating and correctly positioned in their support,
- the water-side connections are clean and show no sign of leakage.

11.7 - Compressor maintenance

11.7.1 - Oil filter change schedule

As system cleanliness is critical to reliable system operation, there is a filter in the oil line at the oil separator outlet. The oil filter is specified to provide a high level of filtration (5 µm) required for long compressor life.

The filter should be checked after the first 500 hours of operation, and every subsequent 2000 hours. The filter should be replaced at any time when the pressure differential across the filter exceeds 2 bar.

The pressure drop across the filter can be determined by measuring the pressure at the discharge port (at the oil separator) and the oil pressure port (at the compressor). The difference in these two pressures will be the pressure drop across the filter, check valve, and solenoid valve. The pressure drop across the check valve and solenoid valve is approximately 0.4 bar, which should be subtracted from the two oil pressure measurements to give the oil filter pressure drop.

11 - STANDARD MAINTENANCE

11.7.2 - Compressor rotation control

Correct compressor rotation is one of the most critical application considerations. Reverse rotation, even for a very short duration, damages the compressor and can even destroy it.

The reverse rotation protection scheme must be capable of determining the direction of rotation and stopping the compressor within one second. Reverse rotation is most likely to occur whenever the wiring at the compressor terminals has been modified.

To minimise the opportunity for reverse rotation, the following procedure must be applied. Rewire the power cables to the compressor terminal pin as originally wired. Apply a counter-torque at the lower nut at the supply cable terminal during installation.

For replacement of the compressor, a low pressure switch is included with the compressor. This low pressure switch should be temporarily installed as a hard safety on the high pressure part of the compressor. The purpose of this switch is to protect the compressor against any wiring errors at the compressor terminal pin. The electrical contact of the switch would be wired in series with the high pressure switch. The switch will remain in place until the compressor has been started and direction of rotation has been verified; at this point, the switch will be removed.

The switch that has been selected for detecting reverse rotation is Carrier part number HK01CB001. This switch opens the contacts when the pressure falls below 7 kPa.

The switch is a manual reset type that can be reset after the pressure has once again risen above 70 kPa. It is critical that the switch be a manual reset type to preclude the compressor from short cycling in the reverse direction.

11.8 - Frequency variator maintenance

ATTENTION: Before any intervention at the frequency variator, ensure that the disconnect/isolator switch is open and that no voltage is present (reminder: the capacitor discharge time is approximately 20 minutes).

Only a well-qualified person is allowed to replace or modify the components inside the frequency variator.

During periodic inspections, check the ventilation grilles at the frequency variator door; ensure that they are not pierced, damaged or obstructed.

Replace the fan, if a "replace fan" alert/warning is displayed in the alarm list.

For any other alarm or problem at the frequency variator, contact the Carrier service department.

The frequency variators do not require a dielectric test, even if they are replaced parts: they are systematically checked before delivery. Otherwise the filtering components installed in the frequency variator can falsify the measurement and may even be damaged.

If it is necessary to test the insulation of a component (e.g. compressor, cables) the frequency variator must be disconnected at the power circuit.

11.9 - High pressure safety loop periodic test

The aim of this periodic test is to check the settings of the high pressure safety loop on one of the unit's refrigerant circuits and check it is operating correctly. This procedure must be repeated for each circuit.

11.9.1 - Complete safety loop test

The purpose of this periodic test is to verify the proper functioning and setting of the high-pressure safety loop of a refrigerant circuit.

In order to reach the triggering pressure of the loop, the pressure and temperature thresholds activating the discharge of the compressor by the regulation system are raised.

This procedure must be repeated for each circuit of the unit.

1. Set up a calibrated pressure gauge on the high pressure part of the circuit (compressor discharge)
2. Reset all activated alarms
3. Activate the HP test mode for the corresponding circuit via the control interface.

Enable Quick Test Mode (Quick Test Menu> [QCK_TEST] parameter active)

Activate the high pressure test for the desired circuit (Menu Quick Test> parameter [HP_TEST] to 0 for circuit A or 1 for the B circuit. The corresponding circuit starts to perform the HP test.

4. Getting Started Machine
5. For water-cooled units, stop the circulation of the secondary circuit to the condenser in order to stop the condensation and cause the increase in pressure (this operation is managed by the control on air-cooled machines)
6. Record the trigger value
7. Check that both HPS were triggered

If both HPS have tripped, go to step 10

If only one of the HPS has tripped, go to step 8

8. Replace the triggered HPS with another system whose trigger value is adequate .

Alternatively, an emergency stop button can be installed.

9. Repeat steps 2 to 6
10. Check if the trigger values are correct

The release values should be between $-1.5 / +0.5$ bars of nominal values indicated on the unit.

11. Reset all alarms
12. Reset all HPS

Note:

Access to the maintenance functions can be protected by a password. Contact your dealer or the manufacturer's service department for more information.

For step 8, the electrical disconnection of the triggered HPS and its substitution must be performed in an environment with live parts. All the procedures and authorization provided for this type of intervention must be respected.

The type of connector must be WAGO 231-302 or equivalent.

12 - START-UP CHECKLIST FOR 30XW-VZE LIQUID CHILLERS (USE FOR JOB FILE)

Preliminary information

Job name:.....
Location:.....
Installing contractor:
Distributor:

Unit

Model:.....

Compressors

Circuit A

Model number.....
Serial number.....
Motor number.....

Circuit B

Model number.....
Serial number.....
Motor number.....

Evaporator

Model number.....
Serial number.....

Condenser Section

Model number.....
Serial number.....

Additional optional units and accessories.....
.....

Preliminary equipment check

Is there any shipping damage? If so, where?

Will this damage prevent unit start-up?

- Unit is level in its installation
- Power supply agrees with the unit nameplate
- Electrical circuit wiring has been sized and installed properly
- Unit ground wire has been connected
- Electrical circuit protection has been sized and installed properly
- All terminals are tight
- All chilled water valves are open
- All chilled water piping is connected properly
- All air has been vented from the chilled water circuit
- The unit is switched off again, after the pump test has been completed
- Chilled water pump (CWP) is operating with the correct rotation. Check the phase sequence of the electrical connection.
- Circulate chilled water in the water circuit for at least two hours, then remove, clean and replace the screen filter.
- The unit is switched off again, after the pump test has been completed.
- Inlet piping to cooler includes a 20 mesh strainer with a mesh size of 1.2 mm.

12 - START-UP CHECKLIST FOR 30XW-VZE LIQUID CHILLERS (USE FOR JOB FILE)

Unit start-up

- Oil level is correct
- All discharge and liquid line valves are open
- Locate, repair and mark all refrigerant leaks
- All suction valves are open, if used
- All oil line valves and economizer valves (if used) are open
- Checks have been carried out for any possible leaks. Unit has been leak checked (including fittings)
 - on the whole unit
 - at all connections
 Locate, repair, and report any refrigerant leaks.....

- Check that control box is vented – Fan on electrical box must be on before compressor start-up and during operation.
- Check voltage imbalance: AB AC..... BC
- Average voltage = V
- Maximum deviation = V
- Voltage imbalance = %
- Voltage imbalance is less than 2%

WARNING: Operation of the chiller with an improper supply voltage or excessive phase imbalance constitutes abuse which will invalidate the Carrier warranty. If the phase imbalance exceeds 2% for voltage, or 10% for current, contact your local electricity supplier at once and ensure that the chiller is not switched on until corrective measures have been taken.

Check cooler water loop

- Water loop volume = litres
- Calculated volume = litres
- 3.25 litres/nominal kW capacity for air conditioning
- 6.5 litres/nominal kW capacity for process cooling
- Proper loop volume established
- Proper loop corrosion inhibitor included..... litres of
- Proper loop freeze protection included (if required).....litres of.....
- Piping includes electric heater tape, if exposed to temperatures below 0°C
- Inlet piping to cooler includes a 20 mesh strainer with a mesh size of 1.2 mm

Check pressure drop across the cooler

- Entering cooler = kPa
- Leaving cooler = kPa
- Leaving - entering = kPa

WARNING: Plot cooler pressure drop on performance data chart (in product data literature) to determine total litres per second (l/s) and find unit's minimum flow rate.

- Total = l/s
- Nominal kW = l/s
- Total l/s is greater than unit's minimum flow rate
- Total l/s meets job specified requirement ofl/s

WARNING: Once power is supplied to the unit, check for any alarms (refer to the SmartVu™ Control IOM for the alarm menu).

Note all alarms:.....



CARRIER participates in the ECP programme for LCP/HP
Check ongoing validity of certificate:
www.eurovent-certification.com

