



**INSTALLATION, OPERATION AND  
MAINTENANCE INSTRUCTIONS**



**Inverter Air-Cooled Liquid Chillers  
Inverter Reversible Air-to-Water Heat Pumps**

30RBV/RQV 17-21

Nominal capacity 17-21 kW



# CONTENTS

---

<b>1 - INTRODUCTION.....</b>	<b>6</b>
1.1 - Introduction.....	6
1.2 - Safety.....	6
1.3 - Preliminary checks.....	10
1.4 - Dimensions, clearances.....	11
1.5 - Physical data and electrical data of 30RBV and 30RQV units.....	13
1.6 - Options and accessories.....	16
<b>2 - INSTALLATION OF UNIT.....</b>	<b>17</b>
2.1 - General.....	17
2.2 - Moving and placing the unit.....	17
2.3 - Water connections.....	20
2.4 - Electrical connections.....	25
2.5 - Water flow rate control.....	27
2.6 - Commissioning modes.....	32
2.7 - Check before start the unit.....	32
3.1 - General customer electrical connection on terminal block.....	33
<b>3 - INSTALLATION OF SYSTEM.....</b>	<b>33</b>
3.2 - First step of configuration: Setting the time and day.....	34
3.3 - Second step of configuration: Parameter menu.....	34
3.4 - Installation with booster electric heaters.....	36
3.5 - Installation with DHW production.....	39
3.6 - Installation with DHW production and boiler.....	42
3.7 - Master / Slave installation.....	44
3.8 - Unit without WUI or with local WUI.....	48
3.9 - Unit with remote user interface.....	50
3.10 - Additional OAT sensor.....	52
3.11 - IAT sensor.....	52
<b>4 - OPERATION.....</b>	<b>53</b>
4.1 - Unit range.....	53
4.2 - Operating modes.....	53
4.3 - Major system components.....	64
<b>5 - MAINTENANCE.....</b>	<b>66</b>
5.1 - Standard maintenance.....	66
5.2 - Tightening torques for the main electrical connections.....	67
5.3 - Tightening torques for the main bolts and screws.....	67
5.4 - Air heat exchanger.....	67
5.5 - Water heat exchanger maintenance.....	67
5.6 - Unit maintenance.....	68
5.7 - Refrigerant volume.....	68
5.8 - Characteristics of R-410A.....	68
<b>6 - ALARM DESCRIPTION.....</b>	<b>69</b>
<b>7 - PARAMETERS OVERVIEW.....</b>	<b>72</b>
<b>8 - START-UP CHECKLIST FOR 30RBV/RQV HEAT PUMPS (USE FOR JOB FILE).....</b>	<b>78</b>
8.1 - General information.....	78
8.2 - Available options and accessories.....	78
8.3 - Checks before start of unit.....	78
8.4 - Checks during operation of unit.....	79
8.5 - Maintenance checks.....	79

The cover photograph is for illustrative purposes only and is not part of any offer for sale or contract.

# FIGURES CONTENT

---

Figure 1: Transport configuration.....	17
Figure 3: Installation configuration.....	17
Figure 2: Offloading configuration .....	17
Figure 4: How to remove front panel .....	19
Figure 5: How to remove right hand panel .....	19
Figure 6: Water connection on unit .....	21
Figure 7: Typical diagram of the hydraulic circuit without the hydraulic module 17-21 kW .....	22
Figure 8: Typical diagram of the hydraulic circuit with the hydraulic module 17-21 kW .....	23
Figure 9: Fixed speed Hydraulic module with expansion tank and Water filling system .....	24
Figure 10: Hydraulic module equipped with variable speed single pump low available pressure with expansion tank and Water filling system.....	24
Figure 11: Standard power connection.....	25
Figure 12: Power connection with Main Switch (option).....	25
Figure 13: Customer electrical connection on terminal block.....	33
Figure 14: Password screen.....	35
Figure 15: Standard installation with booster electric heaters.....	36
Figure 16: Electrical connection on terminal block for booster electric heaters.....	37
Figure 17: Standard installation with DHW production .....	39
Figure 18: Electrical connection on terminal block for DHW production.....	40
Figure 19: Standard installation with DHW production and boiler .....	43
Figure 20: Electrical connection on terminal block for DHW production and boiler.....	43
Figure 21: Standard installation with Master / Slave (example with 3 slaves).....	45
Figure 22: Electrical connection on terminal block for Master / Slave installation .....	45
Figure 23: WUI screen for Slave 1 .....	48
Figure 24: Electrical connection of remote interface .....	50
Figure 25: Electrical connection of additional OAT sensor and IAT sensor .....	52
Figure 26: Winter position for unit with hydraulic module .....	59
Figure 27: Winter position for unit without hydraulic module .....	59
Figure 28: Operation of booster and backup.....	62
Figure 29: Activation and configuration for drying mode .....	63
Table 1: Minimum and maximum wire section (per phase) for connection to 30RBV/RQV units.....	26
Table 2: Steps to clean, purge, and define a flow rate for hydraulic circuit .....	28
Table 3: Actions in WUI parameter menu or Service tools to activate the cleaning purge and control of flow rate for hydraulic circuit ..	29
Table 4: Different operating modes.....	54
Table 5: Possible switches to install on system .....	55
Table 6: Possible setpoint configurations .....	55
Table 7: Different configurations of pump .....	61
Table 8: Different control logic for main pump .....	61
Table 9: Different control logic for additional pump.....	61
Table 10: Alarms listing.....	69
Graphic 1: Pressure drop for unit without hydraulic module 17 and 21 kW (heat exchanger + internal piping).....	30
Graphic 2: Available external static pressure for unit with fixed speed hydraulic module 17 and 21kW .....	30
Graphic 3: Available external static pressure for 17kW unit with variable speed hydraulic module .....	31
Graphic 4: Available external static pressure for 21kW unit with variable speed hydraulic module .....	31

The cover photograph is for illustrative purposes only and is not part of any offer for sale or contract.

# ACRONYMS AND LEGEND

## Acronyms

<b>IAT</b>	Indoor Air Temperature
<b>BPHE</b>	Brazed Plate Heat Exchanger
<b>CHWS</b>	Chiller Water System
<b>DHW</b>	Domestic Hot Water
<b>EHS</b>	Electric Heater Stage
<b>EWI</b>	Entering Water Temperature
<b>FCU</b>	Fan Coil Unit
<b>LWT</b>	Leaving Water Temperature
<b>NHC</b>	New Hydraulic Control (refer to wiring diagram 'Main control card')
<b>OAT</b>	Outdoor Air Temperature
<b>PMV</b>	Pulse Modulating Valve
<b>SHC</b>	Space Heating / Cooling Control
<b>TR</b>	Refrigerant Temperature
<b>UFC</b>	Underfloor Cooling
<b>UFH</b>	Underfloor Heating
<b>WUI</b>	User Interface (Wall-mounted User Interface)

## Control Configuration Legend

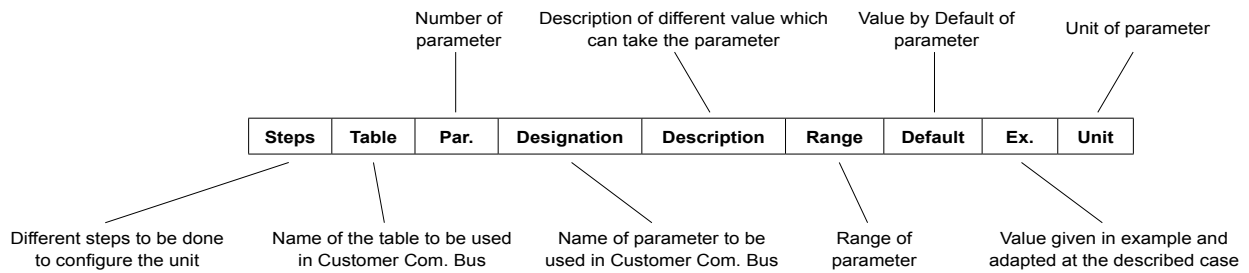

 Possible to configure by direct access on WUI. Refer to WUI end user Manual.

 Check to be done

 Advanced Configuration Level (for basic operation no need to modify the setting)

# ACRONYMS AND LEGEND

## Standard installation Legend

Label	Symbol	Designation	Notes
-		Device	<ul style="list-style-type: none"> <li>Field supplied</li> </ul>
-		Accessory	<ul style="list-style-type: none"> <li>Field mounted</li> </ul>
-		Option	<ul style="list-style-type: none"> <li>Factory mounted</li> </ul>
-		Balancing valve	<ul style="list-style-type: none"> <li>Field supplied</li> <li>Balancing to adjust the water flow rate</li> </ul>
-		Stop valve	<ul style="list-style-type: none"> <li>Field supplied</li> </ul>
-		Automatic Air vent	<ul style="list-style-type: none"> <li>Field supplied</li> <li>Automatic air vent(s) on highest position in the loop</li> </ul>
Add EXP-T		Additional expansion tank	<ul style="list-style-type: none"> <li>Field supplied</li> <li>Additional expansion tank depending the total water in the loop contend - taking in account the expansion tank (XXL) embedded in hydraulic module</li> </ul>
-		Boiler	<ul style="list-style-type: none"> <li>Boiler used to boost or backup the heat pump for comfort</li> </ul>
Eh1 & EH2		Electrical Heater (1 or 2)	<ul style="list-style-type: none"> <li>Electrical heaters up to two with a max. stages up to 3</li> <li>Used to boost or backup the heat pump for comfort</li> </ul>
EH3		DHW-Electrical Heater Backup (1 stage)	<ul style="list-style-type: none"> <li>Domestic Hot Water Electrical Heater - one stage used to backup DHW (when conditions are out of heat pump map)</li> </ul>
DHW-T		Domestic Hot Water - Tank	<ul style="list-style-type: none"> <li>Field supplied</li> </ul>
DHW-S		Domestic Hot Water - Sensor	<ul style="list-style-type: none"> <li>Accessory to mount on top of the DHW-Tank</li> <li>Measure DHW-Temperature</li> </ul>
DHW-V		Domestic Hot Water - Valve or Diverting valve	<ul style="list-style-type: none"> <li>Accessory to be field mounted, it will position the valve to send either to comfort loop or DHW-T, the processed water</li> </ul>
add_pmp		Additional Water Pump	<ul style="list-style-type: none"> <li>Field Supplied, it is used for comfort loop as a secondary loop</li> </ul>
De-Coupling Tank		De-Coupling Tank	<ul style="list-style-type: none"> <li>Field Supplied, it is used to connect different water loop rates as well as to receive the boiler loop</li> </ul>
EH-Boiler		Electrical Heater Boiler	<ul style="list-style-type: none"> <li>Field Supplied, it is used for comfort loop as a Booster Heater (HP+EH) or Backup (EH only) when HP is out of the map.</li> </ul>
-		Flexible	<ul style="list-style-type: none"> <li>Field supply, it is used to lower vibrations transmissions if necessary</li> </ul>
HTSS		High Temperature Safety Switch	<ul style="list-style-type: none"> <li>Field supplied, use to stop system when UFH max, water temperature is triggered</li> </ul>

# 1 - INTRODUCTION

## 1.1 - Introduction

Prior to the initial start-up of the 30RBV/RQV units, the people involved should be thoroughly familiar with these instructions and technical data for the installation.

The 30RBV/RQV outdoor systems are designed to provide a very high level of safety and reliability making installation, start-up, operation and maintenance easier and more secure. They will provide safe and reliable service when operated within their application range.

They are designed for an operating life of 15 years by assuming a 75% utilisation factor; that is approximately 100,000 operating hours.

The procedures in this manual are arranged in the sequence required for machine installation, start-up, operation and maintenance.

Be sure you understand and follow the procedures and safety precautions contained in the instructions supplied with the machine, as well as those listed in this guide, such as: protective clothing such as gloves, safety glasses, safety shoes and appropriate tools, and suitable qualifications (electrical, air conditioning, local legislation).

To find out, if these products comply with European directives (machine safety, low voltage, electromagnetic compatibility, equipment under pressure, etc.) check the declarations of conformity for these products.

## 1.2 - Safety

### 1.2.1. Installation safety considerations

After the unit has been received, and before it is started up, it must be inspected for damage. Check that the refrigerant circuits are intact, especially that no components or pipes have shifted or been damaged (e.g. following a shock). If in doubt, carry out a leak tightness check. If damage is detected upon receipt and before signature, immediately file a claim with the shipping company.

This appliance can be used by children aged from 8 years and above and persons with reduced physical, sensory or mental capabilities or lack of experience and knowledge if they have been given supervision or instruction concerning use of the appliance in a safe way and understand the hazards involved.

Children should be supervised to ensure that they do not play with the appliance.

**Do not remove the pallet or the packaging until the unit is in its final position. These units can be moved with a fork lift truck, as long as the forks are positioned in the right place and direction on the unit.**

**The units can also be lifted with slings (refer to Figure 1 and 2).**

**Use slings with the correct capacity, and always follow the lifting instructions on the certified drawings supplied for the unit.**

**Safety is only guaranteed, if these instructions are carefully followed. If this is not the case, there is a risk of material deterioration and injuries to personnel.**

**DO NOT COVER ANY PROTECTION DEVICES.**

**This applies to fuse plugs and relief valves (if used) in the refrigerant or heat transfer medium circuits. Check if the original protection plugs are still present at the valve outlets. These plugs are generally made of plastic and should not be used. If they are still present, please remove them. Install devices at the valve outlets or drain piping that prevent the penetration of foreign bodies (dust, building debris, etc.) and atmospheric agents (water can form rust or ice). These devices, as well as the drain piping, must not impair operation and not lead to a pressure drop that is higher than 10% of the control pressure.**

### Classification and control

**In accordance with the Pressure Equipment Directive and national usage monitoring regulations in the European Union the protection devices for these machines are classified as follows:**

	Safety accessory <sup>(1)</sup>	Damage limitation accessory <sup>(2)</sup> in case of an external fire
<b>Refrigerant side</b>		
High-pressure switch	X	
External relief valve <sup>(3)</sup>		X
Rupture disk		X
Fuse plug		X
<b>Heat transfer fluid side</b>		
External relief valve	<sup>(4)</sup>	<sup>(4)</sup>

(1) Classified for protection in normal service situations.

(2) Classified for protection in abnormal service situations.

(3) The instantaneous over-pressure limited to 10% of the operating pressure does not apply to this abnormal service situation. The control pressure can be higher than the service pressure. In this case either the design temperature or the high-pressure switch ensures that the service pressure is not exceeded in normal service situations.

(4) The classification of these relief valves must be made by the personnel that completes the whole hydraulic installation.

**Do not remove these valves and fuses, even if the fire risk is under control for a particular installation. There is no guarantee that the accessories are reinstalled if the installation is changed or for transport with a gas charge.**

**When the unit is subjected to fire, safety devices prevent rupture due to over-pressure by releasing the refrigerant. The fluid may then be decomposed into toxic residues when subjected to the flame:**

- Stay away from the unit.
- Set up warnings and recommendations for personnel in charge to stop the fire.
- Fire extinguishers appropriate to the system and the refrigerant type must be easily accessible.

**All factory-installed relief valves are lead-sealed to prevent any calibration change.**

**Relief valves must be checked periodically. See paragraph §1.2.4. Repair safety considerations.**

**Provide a drain in the discharge circuit, close to each relief valve, to avoid an accumulation of condensate or rain water.**

**All precautions concerning handling of refrigerant must be observed in accordance with local regulations.**

**Accumulation of refrigerant in an enclosed space can displace oxygen and cause asphyxiation or explosions.**

**Inhalation of high concentrations of vapour is harmful and may cause heart irregularities, unconsciousness, or death. Vapour is heavier than air and reduces the amount of oxygen available for breathing. These products cause eye and skin irritation. Decomposition products can be hazardous.**

### 1.2.2 - Equipment and components under pressure

These products incorporate equipment or components under pressure, produced by manufacturers. We recommend that you consult your appropriate national trade association or the owner of the equipment or components under pressure (declaration, re-qualification, retesting, etc.). The characteristics of this equipment/these components are given on the nameplate or in the required documentation, supplied with the products. These units comply with the European Pressure Equipment Directive.

The units are intended to be stored and operate in an environment where the ambient temperature must not be less than the lowest allowable temperature indicated on the nameplate.

# 1 - INTRODUCTION

**Do not introduce significant static or dynamic pressure with regard to the operating pressures used during operation or for tests in the refrigerant circuit or in the heat exchange circuits.**

**NOTES:**

**Monitoring during operation, re-qualification, re-testing, exemption from retesting:**

- Follow local regulations on the monitoring of pressure-containing equipment.
- The user or the operator is usually requested to create and maintain a monitoring and maintenance register.
- In absence of regulation or in addition to the regulations, follow the guidance in EN 378 and ISO 5149.
- Follow the local professional recommendations, whenever they exist.
- Regularly monitor the surface of the components to detect cavernous corrosion. To do this check an uninsulated part of the pressure vessel or at a joint in the insulation.
- Regularly check for possible presence of impurities (e.g. silicon grains) in the heat exchange fluids. These impurities can cause wear and/or pitting corrosion.
- Filter the heat exchange fluid.
- The reports of the periodical checks by the user or the operator must be included in the monitoring and maintenance register.

**Repair:**

**Any repair or modification of a pressure vessel is prohibited.**

**Only the replacement of the vessel by an original part from the manufacturer is allowed. In this case, the replacement must be carried out by a qualified technician. The replacement of the vessel must be entered in the monitoring and maintenance register.**

**Recycling:**

**The pressure equipment can be recycled in whole or in part. After use they may contain refrigerant vapours and oil residue. Some parts are painted.**

### 1.2.3 - Maintenance safety considerations

Manufacturer recommends the following drafting for a logbook (the table below should not be considered as reference and does not involve Manufacturer responsibility):

Intervention		Name of the commissioning engineer	Applicable national regulations	Verification Organism
Date	Nature <sup>(1)</sup>			

(1) Maintenance, repairs, regular verifications (EN 378), leakage, etc.

Professional technicians working on the electric or refrigeration components must be authorized, trained and fully qualified to do so.

All refrigerant circuit work must be carried out by a trained person, fully qualified to work on these units. He must have been trained and be familiar with the equipment and the installation. All welding operations must be carried out by qualified specialists.

The units use high-pressure R-410A refrigerant (the unit operating pressure is above 40 bar, the pressure at 35°C air temperature is 50% higher than for R-22). Special equipment must be used when working on the refrigerant circuit (pressure gauge, charge transfer, etc.).

**Cleaning and user maintenance shall not be made by children without supervision.**

**Do not clean the unit with hot water or steam. This may cause a pressure increase of the refrigerant.**

**Any manipulation (opening or closing) of a shut-off valve must be carried out by a qualified and authorised technician, observing applicable standards (e.g. during draining operations). The unit must be switched off while this is done.**

**Equip the engineers that work on the unit as follows:**

Personal protection equipment (PPE) <sup>(1)</sup>	Operations		
	Handling	Maintenance, service	Welding or brazing <sup>(2)</sup>
Protective gloves, eye protection, safety shoe, protective clothing.	X	X	X
Ear protection.		X	X
Filtering respirator.			X

(1) We recommend to follow the instructions in EN 378-3.

(2) Performed in the presence of A1 refrigerant according to EN 378-1.

**Never work on a unit that is still energized. Never work on any of the electrical components, until the general power supply to the unit has been cut.**

**If any maintenance operations are carried out on the unit, lock the power supply circuit in the open position and secure the machine upstream with a padlock.**

**If the work is interrupted, always ensure that all circuits are still de-energized before resuming the work.**

**CAUTION:**

**Even if the unit has been switched off, the power circuit remains energized, unless the unit or customer circuit disconnect switch is open. Refer to the wiring diagram for further details. Attach appropriate safety labels. When working in a fan area, specifically if the grilles have to be removed, isolate the power supply to the fans to prevent their operation.**

**CAUTION:**

**The variable frequency drives (VFD) fitted to the units have the circuit capacitors whose discharge time is five (5) minutes after disconnecting the power supply.**

**After disconnecting the power supply of the control box, wait for 5 minutes before accessing the control box.**

**Before any intervention, verify that there is no voltage present at any accessible conducting parts of the power circuit.**

**Moreover be careful of contact with zones at hot temperature inside the unit, which can exist after the operation of unit (refrigerant and electronic parts).**

**It is recommended to install an indicating device to show if part of the refrigerant has leaked from the valve. The presence of oil at the outlet orifice is a useful indicator that refrigerant has leaked. Keep this orifice clean to ensure that any leaks are obvious. The calibration of a valve that has leaked is generally lower than its original calibration. The new calibration may affect the operating range. To avoid nuisance tripping or leaks, replace or re-calibrate the valve.**

**OPERATING CHECKS:**

- **IMPORTANT INFORMATION REGARDING THE REFRIGERANT USED:**
- **This product contains fluorinated greenhouse gas covered by the Kyoto protocol.**
- **Refrigerant type: R-410A**
- **Global Warming Potential (GWP): 2088**

**Periodic inspections for refrigerant leaks may be required depending on European or local legislation. Please contact your local dealer for more information.**

# 1 - INTRODUCTION

## CAUTION:

1. Any intervention on the refrigerant circuit of this product should be performed in accordance with the applicable legislation. In the EU, the regulation is called F-Gas, N°517/2014.
2. Ensure that the refrigerant is never released to the atmosphere during installation, maintenance or equipment disposal.
3. The deliberate gas release into the atmosphere is not allowed.
4. If a refrigerant leak is detected, ensure that it is stopped and repaired as quickly as possible.
5. Only a qualified and certified personnel can perform installation operations, maintenance, refrigerant circuit leak test as well as the equipment disposal and the refrigerant recovering.
6. The gas recovery for recycling, regeneration or destruction is at customer charge.
7. Periodic leak tests have to be carried out by the customer or by third parties. The EU regulation set the periodicity here after:

System WITHOUT leakage detection		No Check	12 Months	6 Months	3 Months
System WITH leakage detection		No Check	24 Months	12 Months	6 Months
Refrigerant charge/ circuit (CO <sub>2</sub> equivalent)		< 5 Tons	5 ≤ Charge < 50 Tons	50 ≤ Charge < 500 Tons	Charge > 500 Tons <sup>(1)</sup>
Refrigerant charge/ Circuit (kg)	R134A (GWP 1430)	Charge < 3.5 kg	3.5 ≤ Charge < 34.9 kg	34.9 ≤ Charge < 349.7 kg	Charge > 349.7 kg
	R407C (GWP 1774)	Charge < 2.8 kg	2.8 ≤ Charge < 28.2 kg	28.2 ≤ Charge < 281.9 kg	Charge > 281.9 kg
	R410A (GWP 2088)	Charge < 2.4 kg	2.4 ≤ Charge < 23.9 kg	23.9 ≤ Charge < 239.5 kg	Charge > 239.5 kg
	HFO's: R1234ze	No requirement			

(1) From 01/01/2017, units must be equipped with a leakage detection system

8. A logbook must be established for equipments subject to periodic leak tests. It should contain the quantity and the type of fluid present within the installation (added and recovered), the quantity of recycled fluid, regenerated or destroyed, the date and output of the leak test, the designation of the operator and its belonging company, etc.
9. Contact your local dealer or installer if you have any questions.

## Protection device checks:

- If no national regulations exist, check the protection devices on site in accordance with standards EN 378 / ISO 5149: once a year for the high-pressure switches, every five years for external relief valves.

The company or organisation that conducts a pressure switch test shall establish and implement a detailed procedure to fix:

- Safety measures
- Measuring equipment calibration
- Validating operation of protective devices
- Test protocols
- Recommissioning of the equipment.

Consult Service for this type of test. The manufacturer mentions here only the principle of a test without removing the pressure switch:

- Verify and record the setpoints of pressure switches and relief devices (valves and possible rupture discs)
- Be ready to switch-off the main disconnect switch (on the unit or on the installation) of the power supply if the pressure switch does not trigger (avoid over-pressure)
- Connect a calibrated pressure gauge (with Schrader female port of ½ UNF)
- Complete an HP Switch Test as provided by the control system function:

Steps	Table	Par.	Designation	Description	Range	Default	Ex.	Unit
Activate the HP Switch test	QCK_TEST	321	Quick Test enable	Access to Quick test mode	0 to 1	0	1	-
		323	Rating Mode	0 = Rating Off 1 = Rating Cool (set frequency with _RAT_FRQ parameter) 2 = Rating Heat (set frequency with _RAT_FRQ parameter) 3 = Ramp Cool (_RAT_FRQ corresponds to the change rate Hz/min, ramp up if positive, ramp down if negative). 4 = Ramp Heat (_RAT_FRQ corresponds to the change rate Hz/min, ramp up if positive, ramp down if negative). Note: The Rating Mode is implemented for test purpose (Lab tests, ...). When the Rating Mode is active, Water Control Point is ignored by the control. The Pump is forced to run during the Rating Mode.	0 to 4	0	0	-
		322	HP Switch Test	0 = HP Test Off 1 = HP Test Requested 2 = HP Test in Progress 3 = HP Test OK 4 = HP Test Failed due to timeout 5 = HP Test Failed due to Flow Switch Failure 6 = HP Test Failed due to Low Water Temperature 7 = HP Test Failed due to Inverter Failure	0 to 7	0	1	-
		<b>Wait until the HP switch test is finished: when [P322] = 3</b>						
		321	Quick Test enable	When the HP Switch test is finished, exit quick test mode	0 to 1	0	0	-



# 1 - INTRODUCTION

**Note:** *The Rating Mode is implemented for test purpose (Lab tests, ...). When the Rating Mode is active, Water Control Point is ignored by the control.*

*The Pump is forced to run during the Rating Mode. For Master-Slave installation, HP Switch Test shall be executed locally on each unit.*

**CAUTION:**

*If the test leads to replacing the pressure switch, it is necessary to recover the refrigerant charge, these pressure switches are not installed on automatic valves (Schrader type).*

*At least once a year, visually inspect the protection devices (valves, pressure switches).*

*If the machine operates in a corrosive environment, inspect the protection devices more frequently.*

*Check regularly for leaks and repair immediately. Ensure regularly that the vibration levels remain acceptable and close to those at the initial unit start-up.*

*Before opening a refrigerant circuit, transfer the refrigerant to bottles specifically provided for this purpose and consult the pressure gauges.*

*Change the refrigerant after an equipment failure, following a procedure such as the one described in NF E29-795 or carry out a refrigerant analysis in a specialist laboratory.*

*If the refrigerant circuit remains open after an intervention (such as a component replacement, etc.):*

- Seal the openings if the duration is less than a day
- If more than 1 day, charge the circuit with oxygen free nitrogen (inertia principle).

*The objective is to prevent penetration of atmospheric humidity and the resulting corrosion.*

## 1.2.4. Repair safety considerations

All installation parts must be maintained by the personnel in charge to avoid deterioration and injury. Faults and leaks must be repaired immediately. The authorized technician must have the responsibility to repair the fault immediately. After each unit repair check the operation of the protection devices and create a 100% parameter operation report.

Comply with the regulations and recommendations in unit and HVAC installation safety standards, such as: EN 378, ISO 5149, etc.

***If the supply cord is damaged, it must be replaced by the manufacturer, its service agent or similarly qualified persons in order to avoid a hazard.***

### **RISK OF EXPLOSION**



***Never use air or a gas containing oxygen during leak tests to purge lines or to pressurise a machine. Pressurised air mixtures or gases containing oxygen can be the cause of an explosion. Oxygen reacts violently with oil and grease.***

***Only use dry nitrogen for leak tests, possibly with an appropriate tracer gas.***

***If the recommendations above are not observed, this can have serious or even fatal consequences and damage the installation.***

***Never exceed the specified maximum operating pressures. Verify the allowable maximum high- and low-side test pressures by checking the instructions in this manual and the pressures given on the unit name plate.***

***Do not unweld or flame-cut the refrigerant lines or any refrigerant circuit component until all refrigerant (liquid and vapour) as well as the oil have been removed from the heat***

***pump. Traces of vapour should be displaced with dry nitrogen. Refrigerant in contact with an open flame can produce toxic gases.***

***The necessary protection equipment must be available, and appropriate fire extinguishers for the system and the refrigerant type used must be within easy reach.***

***Do not siphon refrigerant.***

***Avoid spilling liquid refrigerant on skin or splashing it into the eyes. Use safety goggles and safety gloves. Wash any spills from the skin with soap and water. If liquid refrigerant enters the eyes, immediately and abundantly flush the eyes with water and consult a doctor.***

***The accidental releases of the refrigerant, due to small leaks or significant discharges following the rupture of a pipe or an unexpected release from a relief valve, can cause frostbites and burns to personnel exposed. Do not ignore such injuries. Installers, owners and especially service technicians for these units must:***

- Seek medical attention before treating such injuries.
- Have access to a first-aid kit, especially for treating eye injuries.

***We recommend to apply standard EN 378-3 Annex 3 and ISO 5149.***

***Never apply an open flame or live steam to a refrigerant circuit. Dangerous overpressure can result.***

***During refrigerant removal and storage operations follow applicable regulations. These regulations, permitting conditioning and recovery of halogenated hydrocarbons under optimum quality conditions for the products and optimum safety conditions for people, property and the environment are described in standard NF E29-795. The units must never be modified to add refrigerant and oil charging, removal and purging devices. All these devices are provided with the units.***

***Refer to the certified dimensional drawings for the units.***

***It is dangerous and illegal to re-use disposable (non-returnable) cylinders or attempt to refill them. When cylinders are empty, evacuate the remaining gas pressure, and move them to a designated place for recovery. Do not incinerate.***

***Do not attempt to remove refrigerant circuit components or fittings, while the machine is under pressure or while it is running. Be sure pressure is at 0 kPa and that the unit has been shut-down and de-energised before removing components or opening a circuit.***

***Do not attempt to repair or recondition any safety devices when corrosion or build-up of foreign material (rust, dirt, scale, etc.) is found within the valve body or mechanism. If necessary, replace the device. Do not install relief valves in series or backwards.***

**CAUTION:**

***No part of the unit must be used as a walkway, rack or support. Periodically check and repair or if necessary replace any component or piping that shows signs of damage.***

***Do not step on refrigerant lines. The lines can break under the weight and release refrigerant, causing personal injury.***

***Do not climb on a machine. Use a platform, or staging to work at higher levels.***

***Use mechanical lifting equipment (crane, hoist, winch, etc.) to lift or move heavy components. For lighter components, use lifting equipment when there is a risk of slipping or losing your balance.***

***Use only original replacement parts for any repair or component replacement. Consult the list of replacement parts that corresponds to the specification of the original equipment.***

# 1 - INTRODUCTION

---

***Do not drain water circuits containing industrial brines, without informing the technical service department at the installation site or a competent body first.***

***Close the entering and leaving water shutoff valves and purge the unit hydraulic circuit, before working on the components installed on the circuit (screen filter, pump, water flow switch, etc.).***

***Periodically inspect all valves, fittings and pipes of the refrigerant and hydraulic circuits to ensure that they do not show any corrosion or any signs of leaks.***

***It is recommended to wear ear defenders, when working near the unit and the unit is in operation.***

***Always ensure you are using the correct refrigerant type before recharging the unit.***

***Charging any refrigerant other than the original charge type (R-410A) will impair machine operation and can even lead to a destruction of the compressors. The compressors operate with R-410A and are charged with asyntheticpolyol-ester oil.***

***Before any intervention on the refrigerant circuit, the complete refrigerant charge must be recovered.***

## 1.3 - Preliminary checks

Check equipment received:

- Inspect the unit for damage or missing parts. If damage is detected, or if shipment is incomplete, immediately file a claim with the shipping company.
- Confirm that the unit received is the one ordered. Compare the name plate data with the order.
- The name plate is attached to the unit in two locations:
  - on the outside on one of the unit sides
  - on the inside.
- The unit name plate must include the following information:
  - Model number - size
  - CE marking
  - Serial number
  - Year of manufacture, pressure and leaktightness test date
  - Fluid being transported
  - Refrigerant used
  - Refrigerant charge per circuit
  - PS: Min./max. allowable pressure (high and low pressure side)
  - TS: Min./max. allowable temperature (high and low pressure side)
  - Pressure switch cut-out pressure
  - Unit leak test pressure
  - Voltage, frequency, number of phases
  - Maximum current drawn
  - Maximum power input
  - Unit net weight
- Confirm that all options ordered for on-site installation have been delivered, and are complete and undamaged.

***The unit must be checked periodically, if necessary removing the insulation (thermal, acoustic), during its whole operating life to ensure that no shocks (handling accessories, tools, etc.) have damaged it. If necessary, the damaged parts must be repaired or replaced. See also chapter §5. Maintenance.***

# 1 - INTRODUCTION

## 1.4 - Dimensions, clearances

### 1.4.1 - Dimensions and location of hydraulic connections

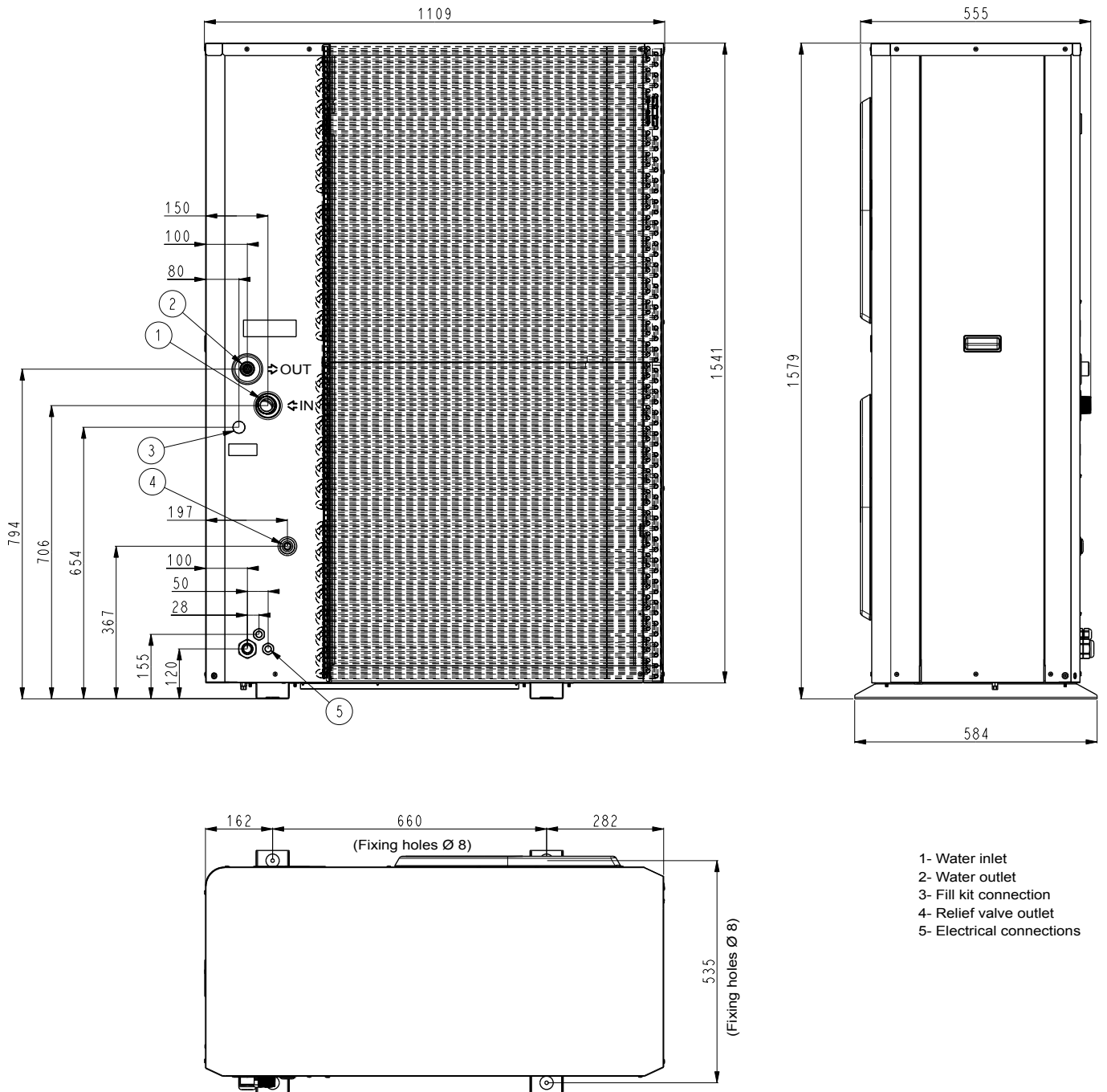

# 1 - INTRODUCTION

## 1.4.2 - User interface and main switch (options)

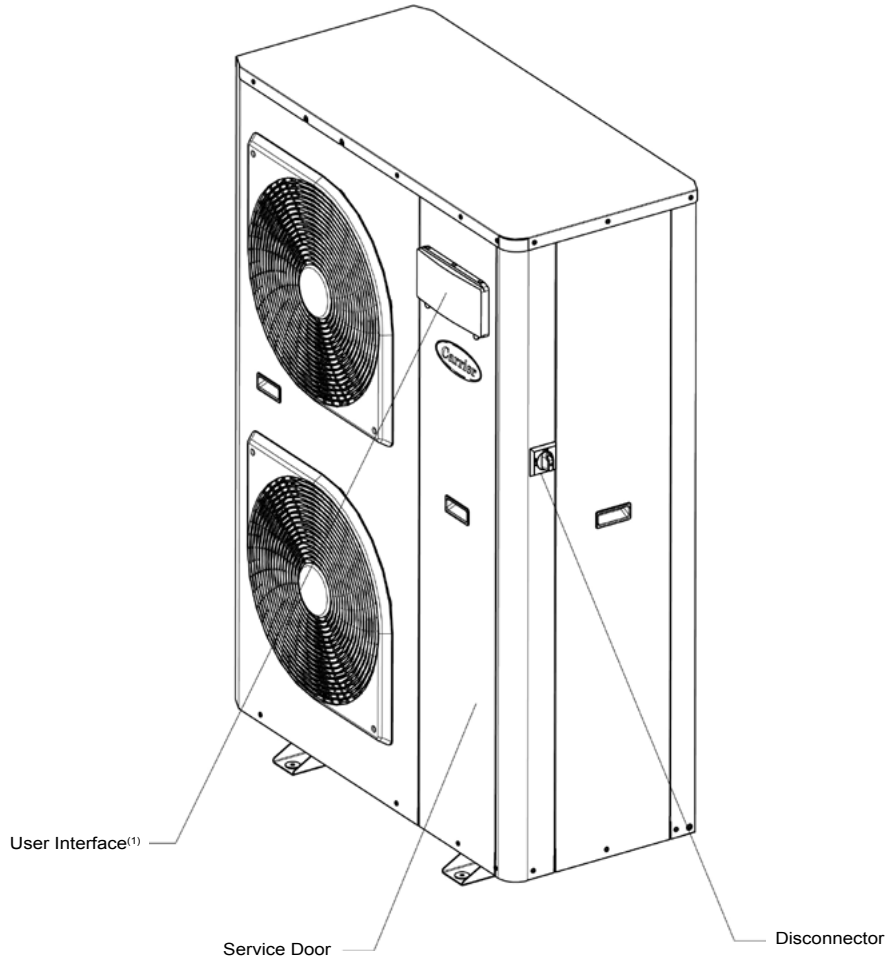

(1) Check that the user interface is protected.

## 1.4.3 - Clearances to ensure the correct air flow

The picture presents the minimal distances of the wall to ensure the correct air flow on air heat exchanger\*.

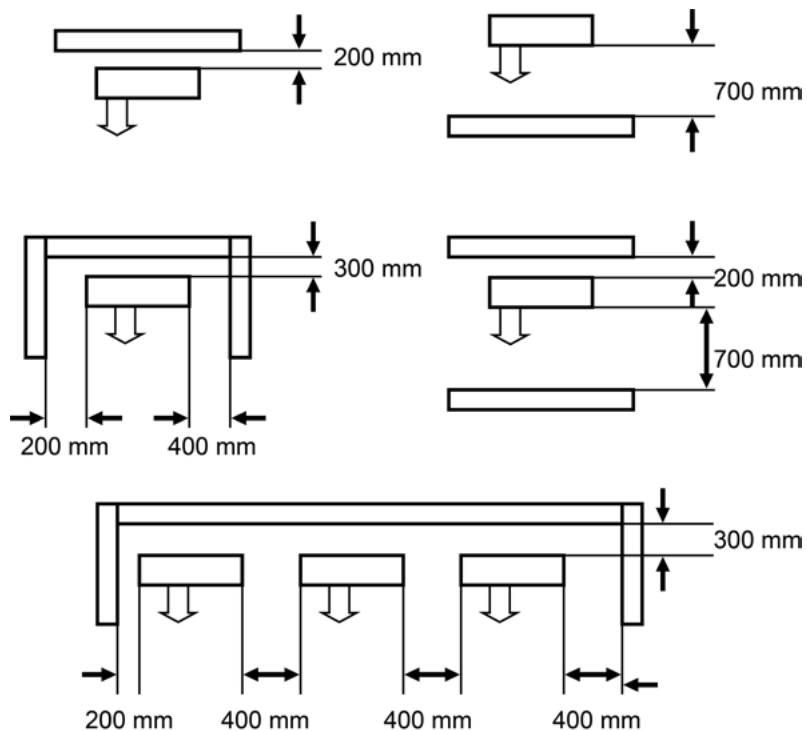

\* Anticipate different maintenance actions before to place the unit (access of different parts / opening of panel/ part replacement...)

# 1 - INTRODUCTION

## 1.5 - Physical data and electrical data of 30RBV and 30RQV units

### 1.5.1 - Physical data 30RBV 17-21

30RBV		17	21
<b>Sound levels</b>			
Standard unit			
Sound power level <sup>(2)</sup>	dB(A)	71	74
Sound pressure level at 10 m <sup>(3)</sup>	dB(A)	40	43
<b>Dimensions - Standard unit</b>			
Length <sup>(5)</sup>	mm	1109	1109
Width	mm	584	584
Height	mm	1579	1579
<b>Operating Weight<sup>(1)</sup></b>			
Standard unit	kg	168,9	176,9
<b>Compressors</b>	Rotary compressor	1	1
<b>Refrigerant</b>		<b>R410A</b>	
Charge <sup>(1)</sup>	kg	6,25	6,25
<b>Capacity control</b>			
Minimum capacity <sup>(6)</sup>	%	33%	41%
<b>Condenser</b>		Grooved copper tubes, aluminium fins	
<b>Fans - Standard unit</b>		Axial type fan	
Quantity		2	2
Maximum total air flow	l/s	2000	2400
Maximum rotational speed	rps	14	16
<b>Evaporator</b>		Braze plate heat exchanger	
Water volume	l	1,52	1,9
Max water-side operating pressure without hydraulic module	kPa	1000	1000
<b>Hydraulic module (options)</b>		Pump, relief valve, paddle flow switch, expansion tank (option)	
Pump		Centrifugal pump (fixed speed or variable speed)	
Expansion tank volume	l	8	8
Max. water-side operating pressure with hydraulic module <sup>(4)</sup>	kPa	300	300
<b>Water connections (Without Hydraulic Module)</b>			
Inlet diameter (BSP GAS)	inch	1	1
Outlet diameter (BSP GAS)	inch	1	1
<b>Water connections (With Hydraulic Module)</b>			
Inlet diameter (BSP GAS)	inch	1-1/4	1-1/4
Outlet diameter (BSP GAS)	inch	1	1
<b>Water Filling System (Option)</b>			
Diameter (BSP GAS)	inch	1/2	1/2
<b>Chassis paint colour</b>	Colour code:	RAL 7035	RAL 7035

(1) Values are guidelines only. Refer to the unit nameplate.

(2) In dB ref=10<sup>-12</sup> W, (A) weighting. Declared dualnumber noise emission values in accordance with ISO 4871 (with an associated uncertainty of +/-3dB(A)). Measured in accordance with ISO 9614-1 and certified by Eurovent.

(3) In dB ref 20 µPa, (A) weighting. Declared dualnumber noise emission values in accordance with ISO 4871 (with an associated uncertainty of +/-3dB(A)). For information, calculated from the sound power level Lw(A).

(4) Min. water-side operating pressure with fixed speed hydraulic module is 50 kPa and with variable speed hydraulic module is 40 kPa.

(5) Length = 1141 mm if main disconnect switch option is chosen

(6) Cooling Eurovent condition

# 1 - INTRODUCTION

## 1.5.2 - Physical data 30RQV 17-21

30RQV		17	21
<b>Sound levels</b>			
Standard unit			
Sound power level <sup>(2)</sup>	dB(A)	71	74
Sound pressure level at 10 m <sup>(3)</sup>	dB(A)	40	43
<b>Dimensions - Standard unit</b>			
Length <sup>(5)</sup>	mm	1109	1109
Width	mm	584	584
Height	mm	1579	1579
<b>Operating Weight<sup>(1)</sup></b>			
Standard unit	kg	190,9	199,4
<b>Compressors</b>	Rotary compressor	1	1
<b>Refrigerant</b>	R410A		
Charge <sup>(1)</sup>	kg	8	8
<b>Capacity control</b>			
Minimum capacity <sup>(6)</sup>	%	33%	41%
<b>Air heat exchanger</b>		Grooved copper tubes, aluminium fins	
<b>Fans - Standard unit</b>		Axial type fan	
Quantity		2	2
Maximum total air flow	l/s	2000	2400
Maximum rotational speed	rps	14	16
<b>Water heat exchanger</b>		Brazen plate heat exchanger	
Water volume	l	1,52	1,9
Max water-side operating pressure without hydraulic module	kPa	1000	1000
<b>Hydraulic module (options)</b>		Pump, relief valve, paddle flow switch, expansion tank (option)	
Pump		Centrifugal pump (fixed speed or variable speed)	
Expansion tank volume	l	8	8
Max. water-side operating pressure with hydraulic module <sup>(4)</sup>	kPa	300	300
<b>Water connections (Without Hydraulic Module)</b>			
Inlet diameter (BSPGAS)	inch	1	1
Outlet diameter (BSP GAS)	inch	1	1
<b>Water connections (With Hydraulic Module)</b>			
Inlet diameter (BSP GAS)	inch	1-1/4	1-1/4
Outlet diameter (BSP GAS)	inch	1	1
<b>Water Filling System (Option)</b>			
Diameter (BSP GAS)	inch	1/2	1/2
<b>Chassis paint colour</b>	Colour code:	RAL 7035	RAL 7035

(1) Values are guidelines only. Refer to the unit nameplate.

(2) In dB ref=10<sup>-12</sup> W, (A) weighting. Declared dualnumber noise emission values in accordance with ISO 4871 (with an associated uncertainty of +/-3dB(A)). Measured in accordance with ISO 9614-1 and certified by Eurovent.

(3) In dB ref 20 µPa, (A) weighting. Declared dualnumber noise emission values in accordance with ISO 4871 (with an associated uncertainty of +/-3dB(A)). For information, calculated from the sound power level Lw(A).

(4) Min. water-side operating pressure with fixed speed hydraulic module is 50 kPa and with variable speed hydraulic module is 40kPa.

(5) Length = 1141 mm if main disconnect switch option is chosen

(6) Cooling Eurovent condition

# 1 - INTRODUCTION

## 1.5.3 - Electrical data 30RBV/RQV 17-21

30RBV / RQV (full options)		17	21
Power circuit			
Nominal power supply	V-ph-Hz	400-3+N-50	400-3+N-50
Voltage range	V	360-440	360-440
Control circuit supply		24V AC via internal transformer	
Nominal unit current drawn (Un) <sup>(1)</sup>	A	7,2	9
Maximum unit power input (Un) <sup>(2)</sup>	kW	10,8	12,4
Cos Phi unit at maximum power <sup>(2)</sup>		0,93	0,93
Maximum unit current drawn (Un-10%) <sup>(3)</sup>	A	18,5	21,2
Maximum unit current drawn (Un) <sup>(4)</sup>	A	16,7	19,2
Maximum Start-up current, standard unit <sup>(5)</sup>	A	Not Applicable (less than the operating current)	

- (1) Conditions equivalent to the standardised Eurovent conditions (evaporator water entering-leaving temperature = 12 °C/7 °C, outside air temperature = 35 °C).  
 (2) Power input, compressors and fans, at the unit operating limits (saturated suction temperature 15 °C, saturated condensing temperature 68.3 °C) and nominal voltage of 400 V (data given on the unit nameplate).  
 (3) Maximum unit operating current at maximum unit power input and at 360 V.  
 (4) Maximum unit operating current at maximum unit power input and at 400 V (values given on the unit nameplate).  
 (5) Maximum instantaneous start-up current at operating limits (maximum operating current of the smallest compressor(s) + fan current + locked rotor current of the largest compressor).

## 1.5.4 - Electrical data, hydraulic module

**The fixed speed pumps that are factory-installed in these units have motors with efficiency class IE2. The additional electrical data required<sup>(1)</sup> is as follows:**

**For fixed speed pump motor (option)**

N <sup>o</sup> (2)	Units	30RBV/RQV 17-21	
1	Nominal efficiency at full load and nominal voltage	%	72.3
1	Nominal efficiency at 75% rated load and nominal voltage	%	70.7
1	Nominal efficiency at 50% rated load and nominal voltage	%	65.6
2	Efficiency level	-	N/A
3	Year of manufacture	-	This information varies depending on the manufacturer and model at the time of incorporation. Please refer to the motor name plates.
4	Manufacturer's name and trademark, commercial registration number and place of manufacturer	-	Same as above
5	Product's model number	-	Same as above
6	Number of motor poles	-	2
7-1	Rated shaft power output at full load and nominal voltage (400V)	kW	0,55
7-2	Maximum power input <sup>(5)</sup> (400 V)	kW	0,82
8	Rated input frequency	Hz	50
9-1	Rated voltage	V	400
9-2	Maximum current drawn <sup>(6)</sup> (400 V)	A	1,58
10	Rated speed	tr/min - tr/s	2800
11	Product disassembly, recycling or disposal at end of life	-	Disassembly using standard tools. Disposal and recycling using an appropriate company.
12	Operating conditions for which the motor is specifically designed		
	I. Altitudes above sea level	m	< 1000 <sup>(4)</sup>
	II. Ambient air temperature	°C	40 <sup>(1)</sup>
	III. Maximum air temperature	°C	Please refer to the operating conditions given in this manual or in the specific conditions in the Manufacturer selection programs.
	IV. Potentially explosive atmosphere	-	N/A

- (1) Required by regulation 640/2009 with regard to the application of directive 2009/125/EC on the eco-design requirements for electrical motors  
 (2) Item number imposed by regulation 640/2009, annex I2b  
 (3) Description given by regulation 640/2009, annex I2b  
 (4) Above 1000m, a degradation of 3% for each 500m should be taken into consideration  
 (5) To obtain the maximum power input for a unit with hydraulic module, add the maximum unit power input from the electrical data table to the pump power input  
 (6) To obtain the maximum unit operating current draw for a unit with hydraulic module, add the maximum unit current draw from electrical data table to the pump current draw

# 1 - INTRODUCTION

## 1.6 - Options and accessories

### 1.6.1 - Options and accessories tables

Options	Description	Advantages	Utilisation
Italcoat coil protection	Fins made of pre-treated aluminium (polyurethane and epoxy)	Improved corrosion resistance, recommended for marine environments	30RBV/RQV 17-21
Main switch	Factory-installed main electric disconnect switch in the control box	Ease-of-installation and compliance with local electrical regulations	30RBV/RQV 17-21
Hydraulic module equipped with variable speed single pump low available pressure without expansion tank	See hydraulic module chapter	Easy and fast installation	30RBV/RQV 17-21
Bacnet gateway	Two-directional communications board, complies with Bacnet protocol	Easy connection by communication bus to a building management system	30RBV/RQV 17-21
Lon gateway	Two-directional communications board, complies with Lon Talk protocol	Easy connection by communication bus to a building management system	30RBV/RQV 17-21
Hydraulic module without expansion tank	Hydraulic module available without expansion tank supply	Expansion tank volume adjustable for the application	30RBV/RQV 17-21
Water filling system	System enabling to fill the hydraulic circuit	Hydraulic circuit easy filling	30RBV/RQV 17-21
Expansion tank	Expansion tank supplied with the hydraulic module	Protection of closed water systems from excessive pressure	30RBV/RQV 17-21
Local human interface	User interface present locally on the unit	Local Heat Pump control. Possibility to configure the unit on field.	30RBV/RQV 17-21

Accessories	Reference	Description	Advantages	Utilisation
Master / Slave up to 4 units sensor	00PSG000596400A	Unit equipped with supplementary water outlet temperature sensor kit to be field-installed allowing master/slave operation of two to four units connected in parallel	Optimised operation of chillers connected in parallel with operating time equalisation	30RBV/RQV 17-21
Domestic hot water management sensor	00PSG002501300A	Sensor enabling to manage the water setpoint inside the tank used for domestic hot water production	Useful for domestic hot water production	30RQV 17-21
Remote human interface	00PSG002521900A	Remotely installed user interface	Remote chiller / heat pump control with room temperature sensor used to offset the water control point. Possibility to configure the unit on field.	30RBV/RQV 17-21
Additional outdoor ambient temperature sensor	00PSG002522000A	Additional outdoor ambient temperature sensor	Better reading of outdoor air temperature	30RBV/RQV 17-21

### 1.6.2 - Model designation

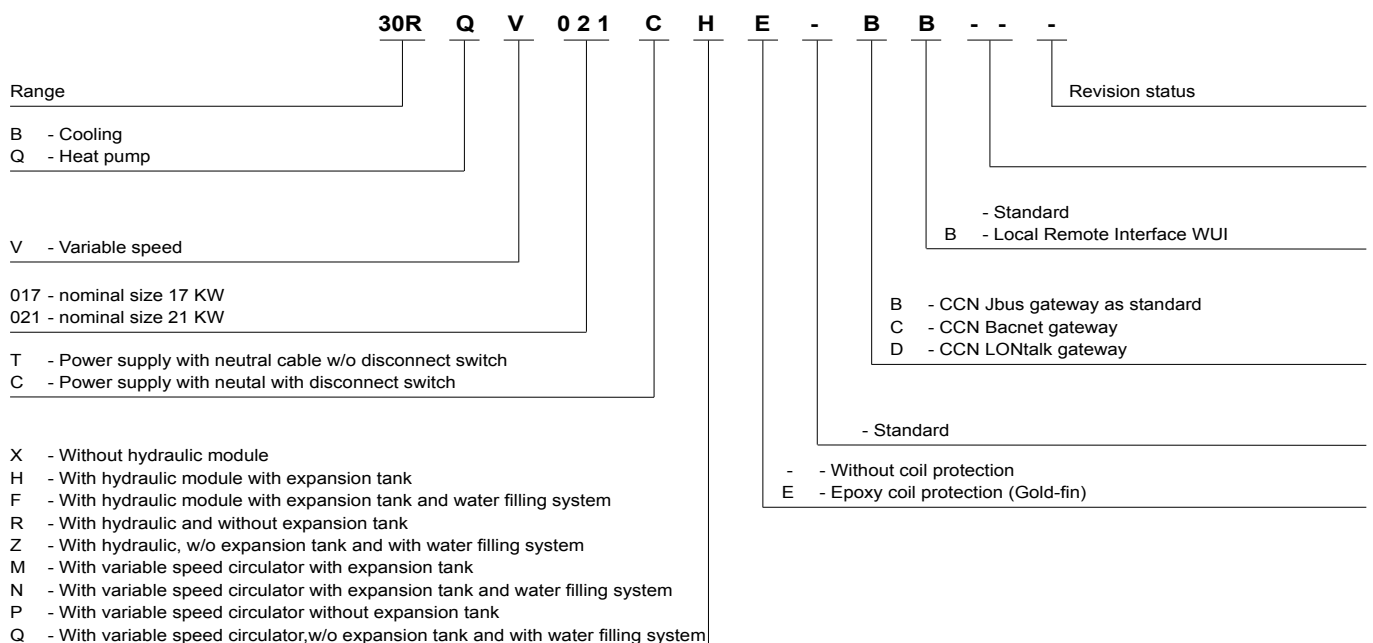



## 2 - INSTALLATION OF UNIT

### 2.1 - General

To install an unit 30RBV/RQV 17-21 kW, do the following:

- 1 • Siting the unit
- 2 • Water connections / Filling the system in water
- 3 • Electrical connections
- 4 • Checking for water leaks / Water Flow rate control
- 5 • Commissioning

### 2.2 - Moving and placing the unit

#### 2.2.1 - Moving

See §1.2.1 *Installation safety considerations.*

Figure 1: Transport configuration

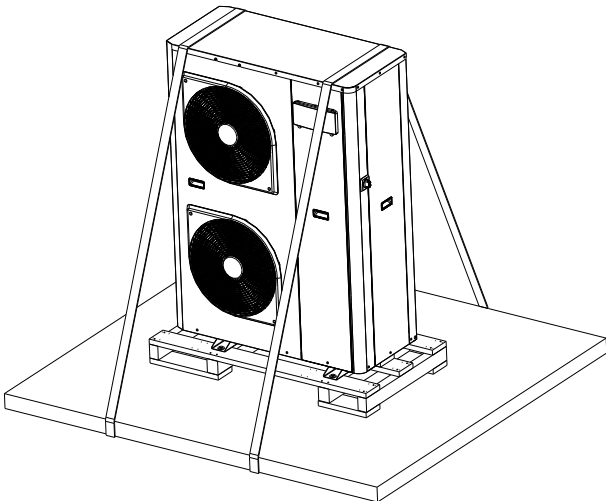

Figure 2: Offloading configuration

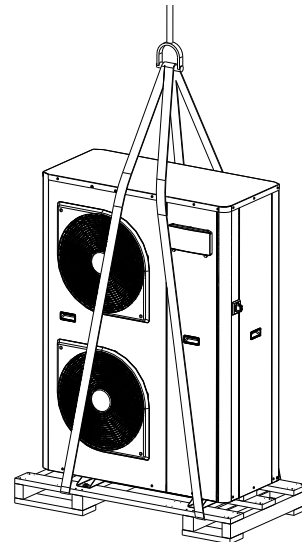
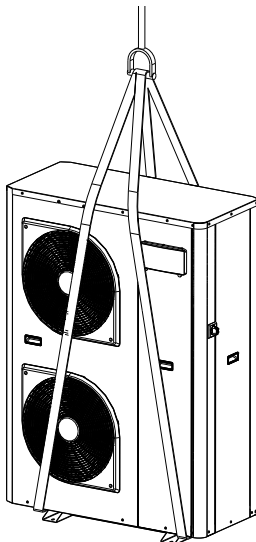

Figure 3: Installation configuration



## 2 - INSTALLATION OF UNIT

---

### 2.2.2 - Placing the unit

*In case of extra-high units the machine environment must permit easy access for maintenance operations.*

*Always refer to § 1.4. Dimensions and clearances to confirm that there is adequate space for all connections and service operations. For the centre of gravity coordinates, the position of the unit mounting holes, and the weight distribution points, refer to the certified dimensional drawing supplied with the unit.*

*Typical applications of these units do not require earthquake resistance. Earthquake resistance has not been verified.*

**CAUTION:**

*Only use slings at the designated lifting points (refer to Figure 2 to offload the unit and Figure 3 to place the unit at final position).*

*Avoid to expose the Outdoor Air temperature sensor (located on coil) to direct sun or to other heat sources.*

Before siting the unit check that:

- the permitted loading at the site is adequate or that appropriate strengthening measures have been taken.
- if the unit has to operate as a heat pump in temperatures below 0°C it must be raised at least 300 mm from the ground. This is necessary to avoid ice build-up on the unit chassis and also to permit correct unit operation in locations where the snow level may reach this height.
- the unit is installed level on an even surface (maximum tolerance is 5 mm in both axes).
- there is adequate space above the unit for air flow and to ensure access to the components (see dimensional drawings).
- the number of support points is adequate and that they are in the right places.
- the location is not subject to flooding.
- for outdoor installations, where heavy snowfall is likely and long periods of sub-zero temperatures are normal, provision has to be made to prevent snow accumulating by raising the unit above the height of drifts normally experienced. Baffles may be necessary to deflect strong winds. They must not restrict air flow into the unit.

**CAUTION:**

*Before lifting the unit, check that all casing panels are securely fixed in place. Lift and set down the unit with great care. Tilting and jarring can damage the unit and impair unit operation.*

If 30RBV/RQV units are hoisted with rigging, it is advisable to protect coils against crushing while a unit is being moved. Use struts or a lifting beam to spread the slings above the unit. Do not tilt a unit more than 15°.

**CAUTION:**

*Never push or lever on any of the enclosure panels of the unit. Only the base of the unit frame is designed to withstand such stresses. If a unit includes a hydraulic module, the hydraulic module and pump piping must be installed in a way that does not submit it to any strain. The hydraulic module pipes must be fitted so that the pump does not support the weight of the pipes.*

## 2 - INSTALLATION OF UNIT

### 2.2.3 - Removing the unit panel

To access at the inside of the unit (refrigerant parts / electrical parts), the panel can be removed. This operation must be carried out by a qualified technician.

**Figure 4: How to remove front panel**

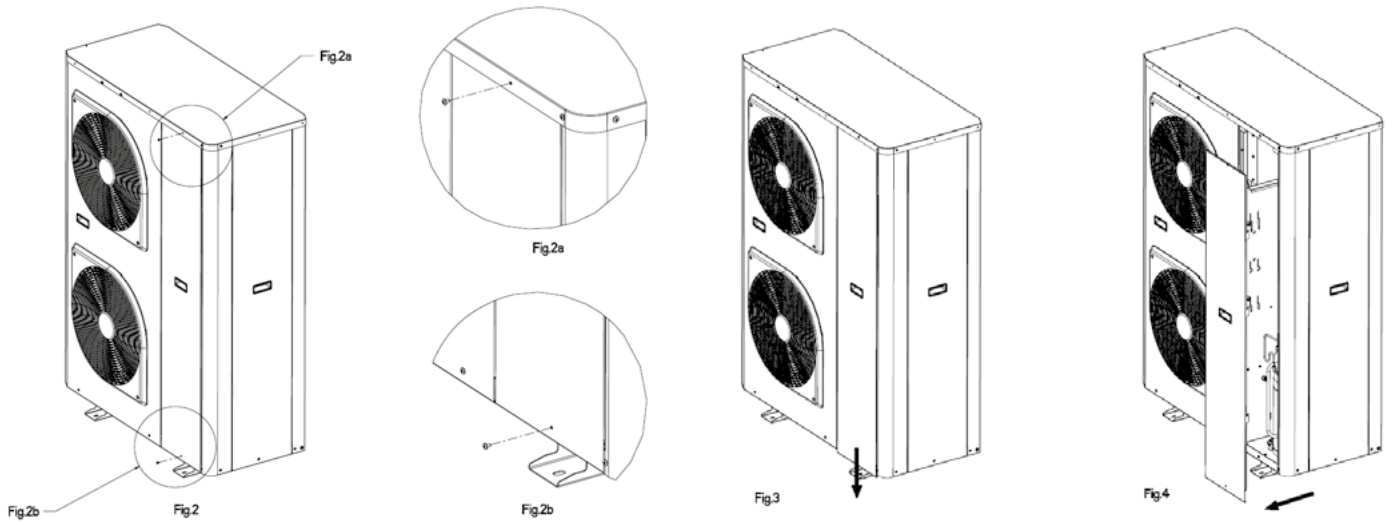

**Figure 5: How to remove right hand panel**

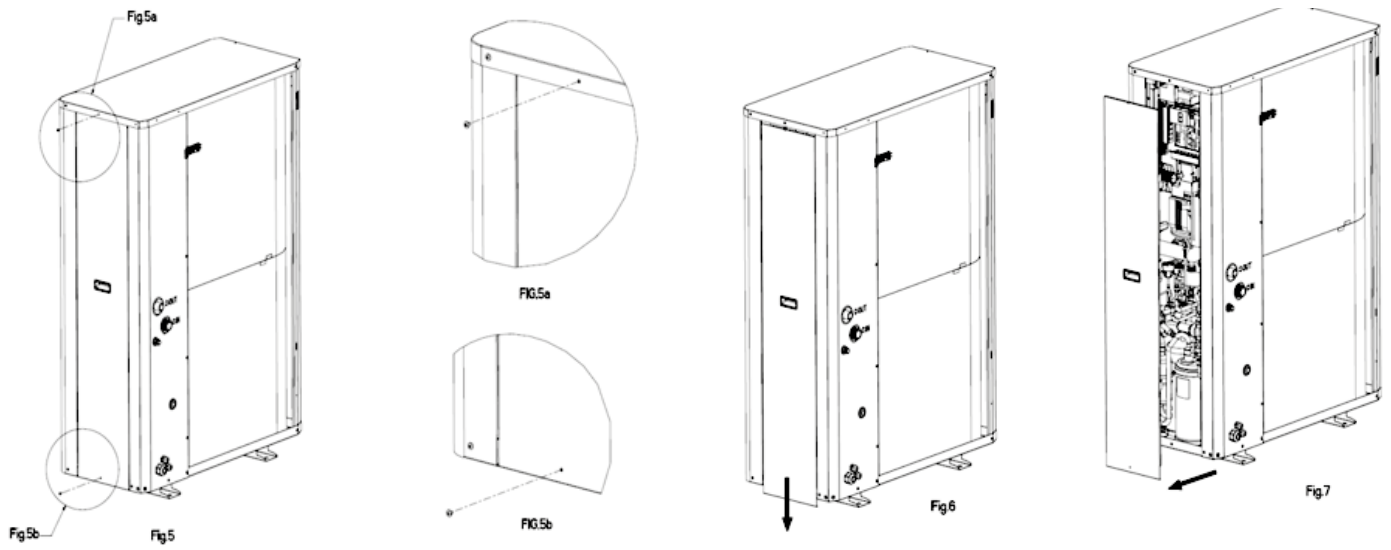

## 2 - INSTALLATION OF UNIT

### 2.2.4 - Checks before system start-up

Before the start-up of the refrigeration system, the complete installation, including the refrigeration system must be verified against the installation drawings, dimensional drawings, system piping and instrumentation diagrams, and wiring diagrams.

For these checks national regulations must be followed. If the national regulation does not specify any details, refer to standard EN 378 / ISO5149 as follows:

External visual installation checks:

- Ensure that the machine is charged with refrigerant. Verify on the unit nameplate that the 'fluid being transported' is R-410A and is not nitrogen.
- Compare the complete installation with the refrigeration system and power circuit diagrams.
- Check that all components comply with the design specifications.
- Check that all protection documents and equipment provided by the manufacturer (dimensional drawings, P&ID, declarations etc.) to comply with the regulations are present.
- Verify that the environmental safety and protection and devices and arrangements provided by the manufacturer to comply with the regulations are in place.
- Verify that all documents for pressure containers, certificates, name plates, files, instruction manuals provided by the manufacturer to comply with the regulations are present.
- Verify the free passage of access and safety routes.
- Verify the instructions and directives to prevent the deliberate removal of refrigerant gases.
- Verify the installation of connections.
- Verify the supports and fixing elements (materials, routing and connection).
- Verify the quality of welds and other joints.
- Check the protection against mechanical damage.
- Check the protection against heat.
- Check the protection of moving parts.
- Verify the accessibility for maintenance or repair and to check the piping.
- Verify the status of the valves.
- Verify the quality of the thermal insulation and of the vapour barriers.

### 2.3 - Water connections

For size and position of the unit water inlet and outlet connections refer to the certified dimensional drawings supplied with the unit. The water pipes must not transmit any radial or axial force to the heat exchangers nor any vibration.

The water supply must be analysed and appropriate filtering, treatment, control devices, shut-off and bleed valves and circuits built in, to prevent corrosion (example: damage to the protection of the tube surface if the fluid is polluted), fouling and deterioration of the pump fittings.

Before any start-up verify that the heat exchange fluid is compatible with the materials and the water circuit coating.

In case additives or other fluids than those recommended by the manufacturer are used, ensure that the fluids are not considered as a gas, and that they belong to class 2, as defined in directive 2014/68/EU.

#### **Recommendations on heat exchange fluids:**

- No  $\text{NH}_4^+$  ammonium ions in the water, they are very detrimental for copper. This is one of the most important factors for the operating life of copper piping. A content of several tenths of mg/l will badly corrode the copper over time.
- $\text{Cl}^-$  Chloride ions are detrimental for copper with a risk of perforations by corrosion by puncture. If possible keep below 10 mg/l.

- $\text{SO}_4^{2-}$  sulphate ions can cause perforating corrosion, if their content is above 30 mg/l.
- No fluoride ions (<0.1 mg/l).
- No  $\text{Fe}^{2+}$  and  $\text{Fe}^{3+}$  ions with non negligible levels of dissolved oxygen must be present. Dissolved iron < 5 mg/l with dissolved oxygen < 5 mg/l.
- Dissolved silica: silica is an acid element of water and can also lead to corrosion risks. Content < 1mg/l.
- Water hardness: >0.5 mmol/l. Values between 1 and 2.5 mmol/l can be recommended. This will facilitate scale deposit that can limit corrosion of copper. Values that are too high can cause piping blockage over time. A total alkalimetric titre (TAC) below 100 is desirable.
- Dissolved oxygen: Any sudden change in water oxygenation conditions must be avoided. It is as detrimental to deoxygenate the water by mixing it with inert gas as it is to over-oxygenate it by mixing it with pure oxygen. The disturbance of the oxygenation conditions encourages destabilisation of copper hydroxides and enlargement of particles.
- Electric conductivity: 0.001-0.06 S/m (10-600  $\mu\text{S}/\text{cm}$ ).
- pH: Ideal case pH neutral at 20-25°C (7 < pH < 8).

#### **CAUTION:**

**Charging, adding or draining fluid from the water circuit must be done by qualified personnel, using air vents and materials suitable for the products. Water circuit charging devices are field-supplied.**

**Charging and removing heat exchange fluids should be done with devices that must be included on the water circuit by the installer. Never use the unit heat exchangers to add heat exchange fluid.**

#### **CAUTION:**

**The use of units in an open loop is forbidden.**

### 2.3.1 - Operating precautions and recommendations

The water circuit should be designed to have the least number of elbows and horizontal pipe runs at different levels. Below the main points to be checked for the connection:

- Comply with the water inlet and outlet connections shown on the unit.
- Install manual or automatic air purge valves at all high points in the circuit.
- Use a pressure reducer to maintain pressure in the circuit(s) and install a relief valve as well as an expansion tank. Units with the hydraulic module include a relief valve and an expansion tank (if option chosen).
- Install thermometers in both the entering and leaving water connections.
- Install drain connections at all low points to allow the whole circuit to be drained.
- Install stop valves, close to the entering and leaving water connections.
- Use flexible connections to reduce vibration transmission.
- Insulate all pipework, after testing for leaks, both to reduce thermal leaks and to prevent condensation.
- Wrap the insulations with a demisting screen.
- If the external unit water pipes are in an area where the ambient temperature is likely to fall below 0°C, they must be protected against frost (frost protection solution or trace heating).
- The use of different metals on hydraulic piping could generate electrolytic pairs and consequently corrosion. Verify then, the need to install sacrificial anodes.

## 2 - INSTALLATION OF UNIT

### NOTE:

For units not equipped with a hydraulic module a screen filter must be installed. This must be installed on the water entering pipes close to the unit heat exchanger. It must be located in a position that is easily accessible for removal and cleaning. The mesh size of the filter must be 1.2 mm.

The plate heat exchanger can foul up quickly at the initial unit start-up, as it complements the filter function, and the unit operation will be impaired (reduced water flow rate due to increased pressure drop).

Units with hydraulic module are equipped with this type of filter.

Do not introduce any significant static or dynamic pressure into the heat exchange circuit (with regard to the design operating pressures).

The products that may be added for thermal insulation of the containers during the water piping connection procedure must be chemically neutral in relation to the materials and coatings to which they are applied. This is also the case for the products originally supplied by the manufacturer.

### 2.3.2 - General

For details on connection diameters, refer to §1.5.1 Physical data 30RBV 17-21 and §1.5.2 Physical data 30RQV 17-21.

Figure 6: Water connection on unit

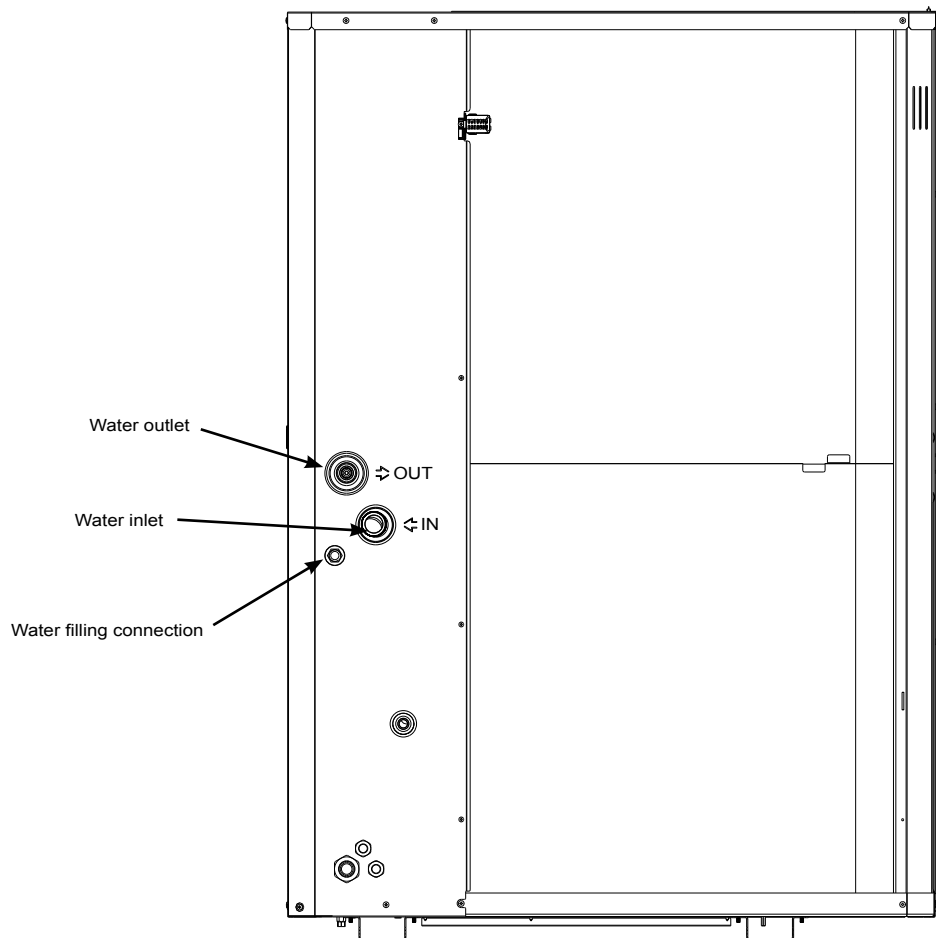

## 2 - INSTALLATION OF UNIT

### 2.3.3 - Minimum water loop volume

The minimum water loop volume, in litres, is given by the following formula:

$$\text{Volume (l)} = \text{CAP (kW)} \times \text{N}$$

Where CAP is the nominal cooling capacity at nominal operating conditions.

Application	N
Air conditioning	3,5
Heating or domestic hot water application	6
Industrial process cooling	See note below

Note: For industrial process cooling applications, where high stability of water temperature levels must be achieved, the values above must be increased. We recommend consulting the factory for these particular applications.

This volume is required to obtain temperature stability and precision. To achieve this volume, it may be necessary to add a storage tank to the circuit. This tank should be equipped with baffles to allow mixing of the fluid (water or brine). Please refer to the examples below.

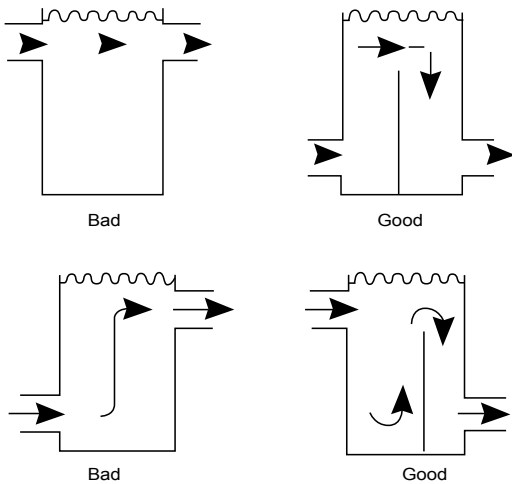

### 2.3.4 - Maximum water loop volume

Units with hydraulic module incorporate an expansion tank (if option chosen) that limits the water loop volume. The table below gives the maximum loop volume for pure water or ethylene glycol with various concentrations.

If the total system volume is higher than the values given above, the installer must add another expansion tank, suitable for the additional volume.

Water maximum volume (L)		
3RBV/RQV 17-21		
Static pressure (bar)	1,5	3
Fresh water	200	50
Ethylene glycol 10%	150	3
Ethylene glycol 20%	110	28
Ethylene glycol 30%	90	23
Ethylene glycol 40%	76	19

### 2.3.5 - Unit without hydraulic kit option

Figure 7: Typical diagram of the hydraulic circuit without the hydraulic module 17-21 kW

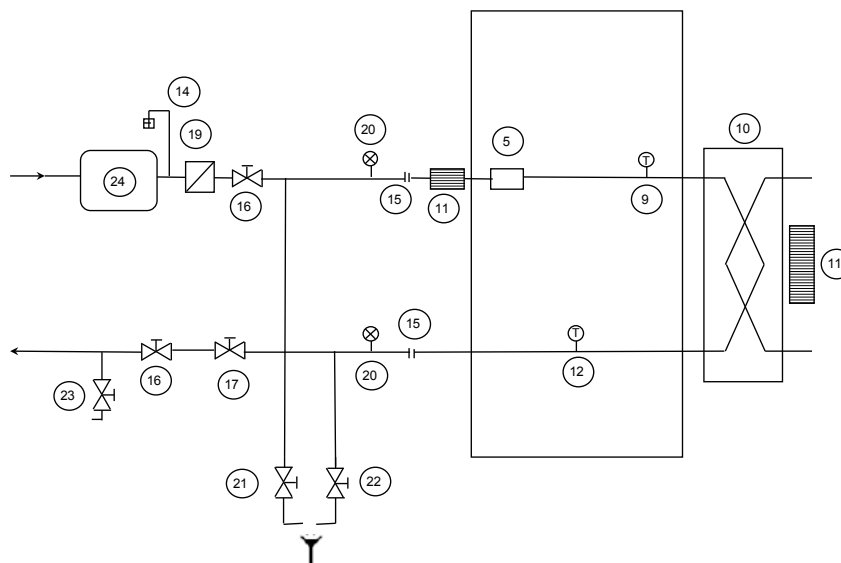

## 2 - INSTALLATION OF UNIT

### 2.3.6 - Unit with hydraulic kit option

Figure 8: Typical diagram of the hydraulic circuit with the hydraulic module 17-21 kW

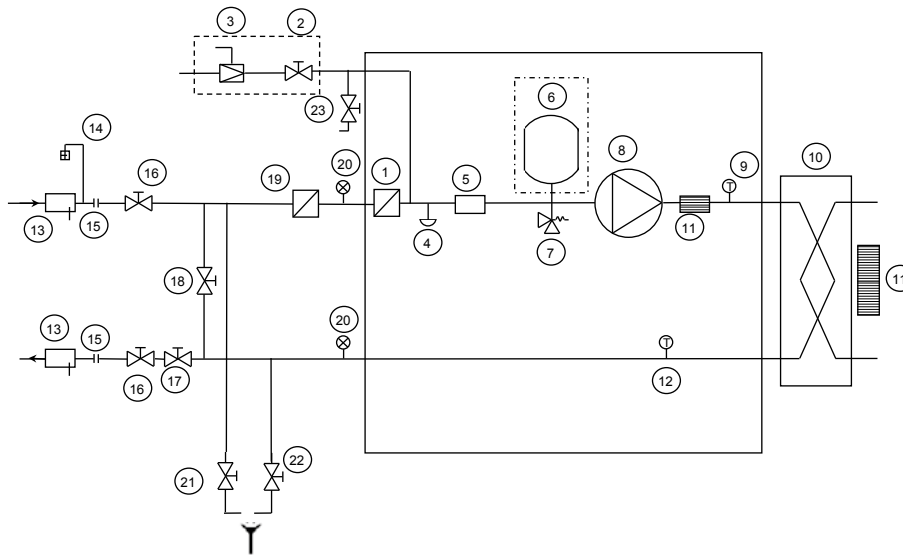

**Legend:**

**HYDRAULIC COMPONENTS**

- 1 Mesh filter
- 2 On/off valve (water filling - optional)
- 3 Pressure reducer (water filling - optional)
- 4 Water drain valve
- 5 Paddle flow switch
- 6 Expansion tank
- 7 Relief valve
- 8 Pump
- 9 Temperature sensor
- 10 Brazed Plate Heat Exchanger
- 11 Anti-freeze electric heater
- 12 Temperature sensor

- Components provided with unit
- Water filling system (option)
- - - Expansion tank (option)

**SYSTEM COMPONENTS**

- 13 Pocket for temperature sensor
- 14 Air purge
- 15 Flexible connections
- 16 On/off valve
- 17 Water flow control valve (factory supplied only with hydraulic module option but to be installed on site)
- 18 Bypass valve for anti-freeze protection (when, in winter, on/off valve are closed)
- 19 Mesh filter (mandatory for a unit without hydraulic kit)
- 20 Pressure gauge
- 21 Water drain valve from the plant
- 22 Water drain valve from refrigerant – water exchanger
- 23 Charge valve
- 24 Buffer tank (if required)

**Note:** The unit must be protected against frost

Several hydraulic options exist on the unit 30RBV/RQV 17-21:

- Hydraulic module without expansion tank
- Hydraulic module equipped with variable speed single pump low available pressure without expansion tank
- Water filling system
- Expansion tank

**CAUTION:** The use of the hydraulic module on open loop is prohibited.

## 2 - INSTALLATION OF UNIT

**Figure 9: Fixed speed Hydraulic module with expansion tank and Water filling system**

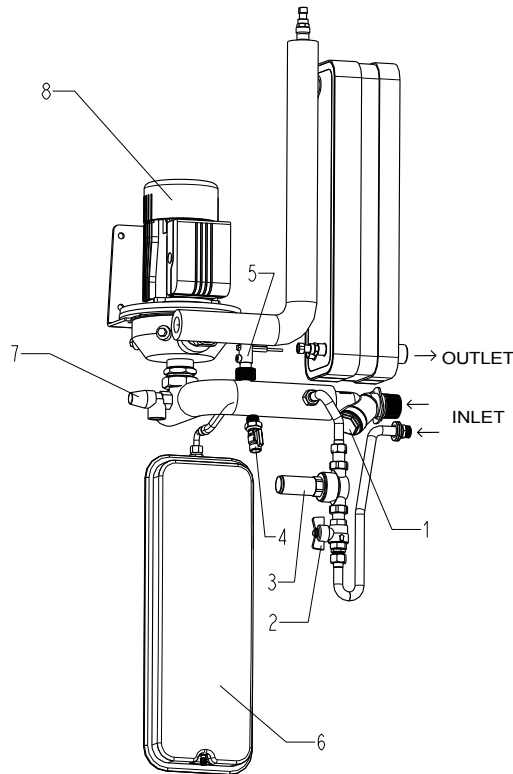

**Figure 10: Hydraulic module equipped with variable speed single pump low available pressure with expansion tank and Water filling system**

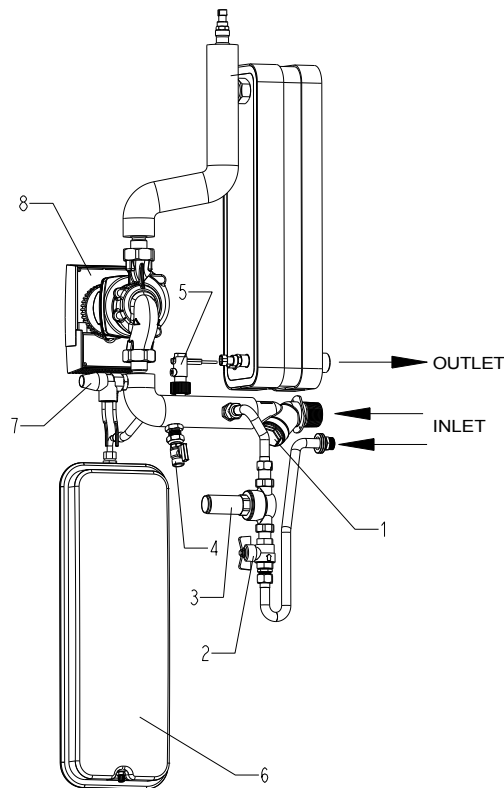

**Legende**

- 1 Mesh filter
- 2 On/off valve (water filling - optional)
- 3 Pressure reducer (water filling - optional)
- 4 Water drain valve
- 5 Paddle flow switch
- 6 Expansion tank
- 7 Relief valve
- 8 Pump

Minimum and maximum pressures necessary in the hydraulic circuit for correct operation of the units.

Hydraulic circuit	Minimum pressure at the suction of the pump to avoid the cavitation phenomena.	Maximum pressure at the suction of the pump before the opening of the water relief valve*
Fixed speed hydraulic module	50kPa (0.5 bar)	300 kPa (3 bar).
Variable speed hydraulic module	40 kPa (0.4 bar)	300 kPa(3 bar).

\* When hydraulic module option is chosen



## 2 - INSTALLATION OF UNIT

### 2.4 - Electrical connections

Please refer to the certified wiring drawings, supplied with the unit.

#### 2.4.1 - Power supply

The power supply must conform to the specification on chiller and heat pump nameplate. The supply voltage must be within the range specified in the electrical data table. For connections refer to the wiring diagrams and the certified dimensional drawings.

**CAUTION:**

*After the unit has been commissioned, the power supply must only be disconnected for quick maintenance operations (one day maximum). For longer maintenance operations or when the unit is taken out of service and stored (e.g. during the winter or if the unit does not need to generate cooling) the power supply must be maintained to ensure supply to the electric heaters (compressor coil heater, unit frost protection).*

According to the choice of options of unit, the power connection is different:

- Either standard unit
- Or Main Switch option

**Figure 11: Standard power connection**

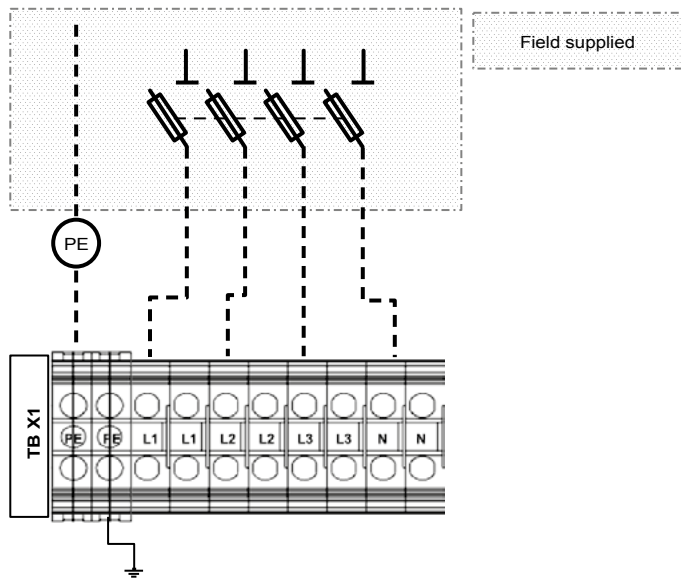

**Figure 12: Power connection with Main Switch (option)**

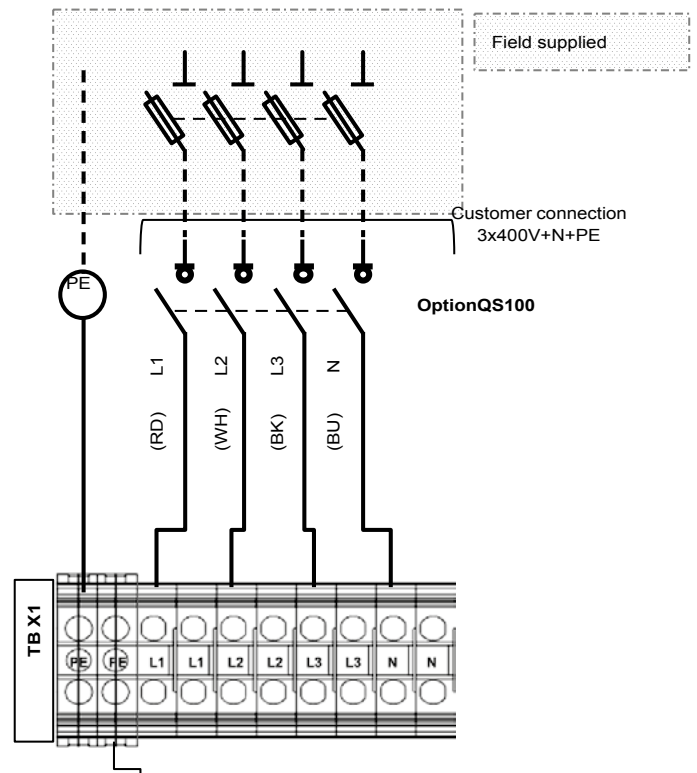

#### 2.4.2 - Recommended wire sections

Wire sizing is the responsibility of the installer, and depends on the characteristics and regulations applicable to each installation site. The following is only to be used as a guideline, and does not make Manufacturer in any way liable. After wire sizing has been completed, using the certified dimensional drawing, the installer must ensure easy connection and define any modifications necessary on site.

The connections provided as standard for the field-supplied power entry cables are designed for the number and type of wires, listed in the table below.

The calculations are based on the maximum machine current (see nameplate and electrical data tables), and standard installation practises, in accordance with IEC 60364, table 52C have been applied:

- No. 17: suspended aerial lines,
- No. 61: buried conduit with a derating coefficient of 20.

The calculation is based on PVC or XLPE insulated cables with copper core. A maximum ambient temperature of 46°C has been taken into consideration. The given wire length limits the voltage drop to < 5% (length L in metres - see table below).

**IMPORTANT:**

**Before connection of the main power cables (L1 - L2 - L3 - N - PE) on the terminal block, it is imperative to check the correct order of the 3 phases before proceeding to the connection and the good connection of the neutral wire (if the neutral conductor is not connected correctly, the unit can be damaged permanently).**

## 2 - INSTALLATION OF UNIT

**Table 1: Minimum and maximum wire section (per phase) for connection to 30RBV/RQV units**

	Max. connectable section <sup>(1)</sup>	Calculation favourable case:			Calculation unfavourable case:		
		- Suspended aerial lines (standardised routing No. 17) - XLPE insulated cable			- Conductors in conduits or multi-conductor cables in closed conduit (standardised routing No. 41) - PVC insulated cable, if possible		
30RBV/RQV	Section	Section <sup>(2)</sup>	Max. length for voltage drop <5%	Cable type	Section <sup>(2)</sup>	Max. length for voltage drop <5%	Cable type <sup>(3)</sup>
	mm <sup>2</sup> (per phase)	mm <sup>2</sup> (per phase)	m	-	mm <sup>2</sup> (per phase)	m	-
17	5G6 <sup>2</sup>	5G4 <sup>2</sup>	100	H07RNF	5G4 <sup>2</sup>	80	H07RNF
21	5G6 <sup>2</sup>	5G4 <sup>2</sup>	100	H07RNF	5G4 <sup>2</sup>	80	H07RNF
<b>Accessory Remote WUI</b>	Use cables H07RN-F 4x0.75 mm <sup>2</sup> up to 50m to connect the user interface WUI (not supplied with accessory) <b>CAUTION:</b> Use the grey ferrite which is supplied in accessory to clamp around the WUI cable. Please clamp it directly after the customer's terminal block						

- Notes:**
- (1) Connection capacities actually available for each machine, defined according to the connection terminal size, the control box access opening size and the available space inside the control box.
  - (2) Selection simulation result considering the hypothesis indicated.
  - (3) If the maximum calculated section is for an XLPE cable type, this means that a selection based on a PVC cable type can exceed the connection capacity actually available. Special attention must be given to the selection.

### Power cable entry

The power cables must be entered through the cable gland from the rear of the unit.

**CAUTION:**

*The power cable does't have to be in touch with hot zones of system.*

*Use the black ferrite which is supplied in accessory to clamp around the supply cable. Please clamp it directly after the customer's terminal block.*

### 2.4.3 - Recommended customer electrical protection

Electrical protection is the responsibility of the installer, and depends on the characteristics and regulations applicable to each installation site. The following is only to be used as a guideline, and does not make manufacturer in any way liable.

30RBV/RQV	17	21
<b>Circuit breaker:</b>		
<b>Type</b>	C	C
<b>Current</b> A	25	25
<b>Fuses:</b>		
<b>Type</b>	gG	gG
<b>Current</b> A	25	25

<b>Electrical data and operating conditions notes:</b>	
<ul style="list-style-type: none"> <li>• 30RBV/RQV 17-21 units have a single power connection point located immediately upstream of the field power connections.</li> <li>• The control box includes the following standard features:               <ul style="list-style-type: none"> <li>- Starter and motor protection devices for the pump,</li> <li>- Variable frequency drive for compressor and fans</li> <li>- The control devices.</li> <li>- A main disconnect switch can be installed within the box with the option.</li> </ul> </li> <li>• <b>Field connections:</b> All connections to the system and the electrical installations must be in full accordance with all applicable local codes.</li> <li>• The 30RBV/RQV units are designed and built in compliance with EN 60335-1 and 2<sup>(1)</sup>.</li> </ul> <p><b>NOTES:</b></p> <ul style="list-style-type: none"> <li>• The operating environment for the 30RBV/RQV units is specified below:</li> </ul> <ol style="list-style-type: none"> <li>1. Physical environment<sup>(2)</sup>. The classification of environment is specified in standard EN 60364:               <ul style="list-style-type: none"> <li>- outdoor installation: protection level IP44<sup>(2)</sup></li> <li>- operating temperature range: -20°C to +46°C</li> <li>- storage temperature range: -20°C to +48°C</li> <li>- altitude: ≤ 2000 m (see note for table 1.5.4 - Electrical data, hydraulic module)</li> <li>- presence of hard solids, class AE3 (no significant dust present)</li> <li>- presence of corrosive and polluting substances, class AF1 (negligible)</li> </ul> </li> </ol>	<ol style="list-style-type: none"> <li>2. Power supply frequency variation: ± 2 Hz.</li> <li>3. The neutral (N) conductor must be always connected to the unit</li> <li>4. Overcurrent protection of the power supply conductors is not provided with the unit.</li> <li>5. The factory-installed disconnect switch (option) is of a type suitable for power interruption in accordance with EN 60947.</li> <li>6. The units are designed for simplified connection on TT networks (IEC 60364).</li> </ol> <p><b>Caution: If particular aspects of an actual installation do not conform to the conditions described above, or if there are other conditions which should be considered, always contact your local representative.</b></p> <ol style="list-style-type: none"> <li>(1) The absence of main power disconnect switch on standard machines is an exception that must be taken into account at field installation level.</li> <li>(2) The required protection level for this class is IP43BW (according to reference document IEC 60529). All 30RBV/RQV units fulfil this protection condition:               <ul style="list-style-type: none"> <li>- Closed electrical box is IP44</li> <li>- When accessing to interface, the level is IPxxB</li> </ul> </li> </ol>

## 2 - INSTALLATION OF UNIT

### 2.5 - Water flow rate control

#### 2.5.1 - Water leakage

Check that the water-side connections are clean and show no sign of leakage.

#### 2.5.2 - Minimum water flow rate

If the installation flow rate is below the minimum flow rate, there is a risk of excessive fouling.

#### 2.5.3 - Maximum water flow rate

This is limited by the permitted water heat exchanger pressure drop. Also, a minimum water heat exchanger  $\Delta T$  of 2.8 K must be guaranteed, which corresponds to a water flow rate of 0.09 l/s per kW.

#### 2.5.4 - Water heat exchanger flow rate

Data applicable for:

- Fresh water 20°C
- In case of use of the glycol, the maximum water flow is reduced.

30RBV/RQV units without hydraulic module		
	Minimum water flow rate, l/s	Maximum water flow rate, l/s
17	0.45	1.3
21	0.57	1.5

30RBV/RQV units with fixed speed hydraulic module		
	Minimum water flow rate, l/s	Maximum water flow rate, l/s
17	0.45	1.4
21	0.57	1.6

30RBV/RQV units with variable speed hydraulic module		
	Minimum water flow rate, l/s	Maximum water flow rate, l/s
17	0.45	1.2
21	0.57	1.2

#### 2.5.5 - Nominal system water flow control

The water circulation pumps of the 30RBV/RQV units have been sized to allow the hydraulic modules to cover all possible configurations based on the specific installation conditions, i.e. for various temperature differences between the entering and the leaving water ( $\Delta T$ ) at full load, which can vary between 3 and 10 K.

This required difference between the entering and leaving water temperature determines the nominal system flow rate. Use this specification for the unit selection to find the system operating conditions.

In particular, collect the data to be used for the control of the system flow rate:

- Unit without a hydraulic module (with external main pump): nominal unit pressure drop (plate heat exchanger + internal piping),
- Unit with fixed speed pump: nominal available external static pressure,
- Units with variable speed pump-control on adjustable constant speed: nominal flow rate,
- Units with variable speed pump - control on temperature difference: heat exchanger  $\Delta T$  (variable flow).

If the information is not available at the system start-up, contact the technical service department responsible for the installation to get it. These characteristics can be obtained from the technical literature using the unit performance tables for a  $\Delta T$  of 5 K at the water heat exchanger.

## 2 - INSTALLATION OF UNIT

**Table 2: Steps to clean, purge, and define a flow rate for hydraulic circuit**

N°	Without Hydraulic module	With Fixed Speed Hydraulic module	With Variable Speed Hydraulic module Adjustable constant speed	With Variable Speed Hydraulic module $\Delta T$	
<b>Cleaning procedure</b>	1	Open the manual control valve fully (item 17).	No manual control valve required with Variable Speed Hydraulic module		
	2	Set the system pump <sup>(1)</sup> .			
	3	Read the BPHE pressure drop...	Read the available external static pressure... ... by taking the difference of the readings of the pressure gauge connected to the unit inlet and outlet (items 20 <sup>(3)</sup> ).		
	4	Let the pump run for two consecutive hours to flush the hydraulic circuit of the system (presence of solid contaminants).			
	5	Take another reading.			
	6	Compare this value to the initial value.			
	7	If the pressure drop...	If the available external static pressure... ... has decreased, this indicates that the screen filter must be removed and cleaned, as the hydraulic circuit contains solid particles.		
	8	In this case stop the pump <sup>(1)</sup> and close the shut-off valves at the water inlet and outlet (items 16) and remove the screen filter (item 19) after emptying the hydraulic section of the unit (items 21 and 22).			
	9	Repeat, if necessary, to ensure that the filter is not contaminated.			
<b>Purge procedure</b>	1	After filling with water, wait about 24h before activating the purge procedure.			
	2	Activate the purge mode <sup>(1)</sup> : water pump is requested to run continuously at maximum speed to purge the hydraulic circuit regardless the flow switch value <sup>(2)</sup> .			
	3	The air purge is field-supplied (item 14 <sup>(3)</sup> ).			
		If the purge is automatic, air will vent from circuit automatically. If the purge is manual, open the valve to vent air from the circuit			
<b>Water flow control procedure</b>	1	When the circuit is cleaned and purged, activate the pump in quick test mode <sup>(1)</sup> , and read the pressures at the pressure gauges (entering water pressure - leaving water pressure), ...			No need to adjust the flow rate because of $\Delta T$ control. But it is necessary to adjust the Minimum pump speed [P567] to ensure closure of flow switch <sup>(1)</sup> .
	2	... to find out the unit pressure drop (plate heat exchanger and internal water piping).			
	3	Compare the value obtained with the pressure drop (Graphic 1).	Compare the value obtained with the available external static pressure (Graphic 2).	Compare this value to the graph of available external static pressure using the appropriate speed curve (Graphics 3 & 4).	
	4	If the pressure read is higher than the value specified the unit flow rate (and thus system flow rate) is too high. The pump supplies an excessive flow rate based on the global pressure drop of the application. In this case close the control valve and read the new pressure difference.		If the flow rate corresponding is higher, decrease pump speed <sup>(1)</sup> , and vice versa.	
	5	Proceed by successively closing the control valve until you obtain the specific pressure that corresponds to the nominal flow rate at the required unit operating point.		Proceed by successively adjusting the pump speed until the expected water flow rate is achieved.	

(1) For configuration details, refer to table 3.

(2) CAUTION: In purge mode, the value of the flow switch is ignored, so check that there is water in the circuit, to avoid damage to the pump.

(3) Refer to figures 7 and 8

## 2 - INSTALLATION OF UNIT

**Table 3: Actions in WUI parameter menu or Service tools to activate the cleaning purge and control of flow rate for hydraulic circuit**

Steps	Table	Par.	Designation	Description	Range	Default	Ex.	Unit		
Cleaning procedure	QCK_TEST	321	Quick Test enable	Access to Quick test mode	0 to 1	0	1	-		
		331	Water Pump Speed	Activate the pump	0 to 100	0	100	%		
		<b>Wait around 2h that the hydraulic circuit is cleaned</b>								
		331	Water Pump Speed	Stop the pump	0 to 100	0	0	0	%	
		321	Quick Test enable	Exit the Quick test mode	0 to 1	0	0	0	-	
Purge procedure	MOD_REQ	44	System Mode Request	8 = Purge (water pump is constantly running to purge the hydraulic circuit) 0 to 6 and 9 = not used for this configuration	0 to 9	-	8	-		
		<b>Wait that the circuit purges</b>								
		44	System Mode Request	To exit purge mode, change the value of [P044] with the wanted mode (0 or 1 or 2 or 4)	0 to 9	-	0 / 1 / 2 / 4	-		
Water flow control procedure	Fixed speed pump (internal or external main pump)	QCK_TEST	321	Quick Test enable	Access to Quick test mode	0 to 1	0	1	-	
			331	Water Pump Speed	Activate the pump	0 to 100	0	100	%	
			<b>Adjust the control valve to set the nominal flow rate (refer to Graphic 2)</b>							
			331	Water Pump Speed	When the pump speed is identified, stop the pump	0 to 100	0	0	0	%
			321	Quick Test enable	Exit the quick mode	0 to 1	0	0	0	-
	Variable speed pump – control on adjustable constant speed	QCK_TEST	321	Quick Test enable	Access to Quick test mode	0 to 1	0	1	-	
			331	Water Pump Speed	Adjust water pump speed until obtain the expected design water flow (refer to Graphics 3 and 4).	0 to 100	0	?	%	
			331	Water Pump Speed	When the pump speed is identified, stop the pump.	0 to 100	0	0	0	%
			321	Quick Test enable	Exit the quick mode	0 to 1	0	0	0	-
	Variable speed pump - control on ΔT	PUM_CONF	566	Var Speed Pump Logic	0 = Adjustable Constant Speed (use [P568] parameter to set the water pump constant speed) 1 = not used for this configuration	0 to 1	1	0	-	
			568	Maximum Pump Speed	If variable speed pump configuration is set to adjustable speed, then the maximum pump speed parameter corresponds to the design water flow.	19 to 100	100	?	Enter pump speed determined at last step [P331] %	
	Variable speed pump - control on ΔT	PUM_CONF	566	Var Speed Pump Logic	1 = Water pump Speed controlled by the Water Delta T 0 = not used for this configuration	0 to 1	1	1	-	
			569	Water Delta T Setpoint	Set a ΔT value	2.0 to 20.0	5	5	K	
Determine the min pump speed to allow closure of flow switch	QCK_TEST	321	Quick Test enable	To determine the minimum pump speed in function of pressure drop and closing of flow switch of hydraulic circuit, activate the quick test	0 to 1	0	1	-		
		331	Water Pump Speed	Increase the water pump speed until the closing of flow switch (to check the status of flow switch refer to parameter Flow Switch Status [P105]: Open (0) / Close (1)) Note: this value change in function of pressure drop of circuit and min possible pump speed is 19% and max possible pump speed is 50%	0 to 100	0	?	%		
		321	Quick Test enable	When the minimum pump speed is determined, exit of quick test mode	0 to 1	0	0	0	-	
	PUM_CONF	567	Minimum Pump Speed	Enter the minimum pump speed	19 to 100	19	?	%		

## 2 - INSTALLATION OF UNIT

### NOTE:

If the system has an excessive pressure drop in relation to the available static pressure provided by the system pump the nominal water flow rate cannot be obtained (the resulting flow rate is lower) and the temperature difference between the water heat exchanger entering and leaving water will increase.

To reduce the pressure drops of the hydraulic system:

- reduce the individual pressure drops as much as possible (bends, level changes, options, etc.).
- use a correctly sized piping diameter.
- avoid hydraulic system extensions, wherever possible.

**Graphic 1: Pressure drop for unit without hydraulic module 17 and 21 kW (heat exchanger + internal piping)**

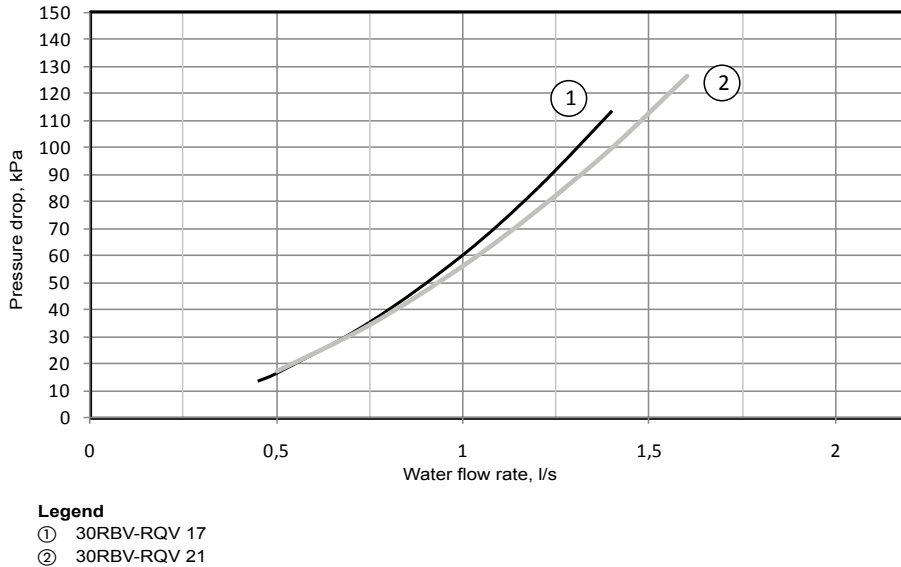

### 2.5.7 - Available external static pressure

Data applicable for:

- Fresh water 20°C
- If glycol is used, the maximum water flow is reduced.

**Graphic 2: Available external static pressure for unit with fixed speed hydraulic module 17 and 21kW**

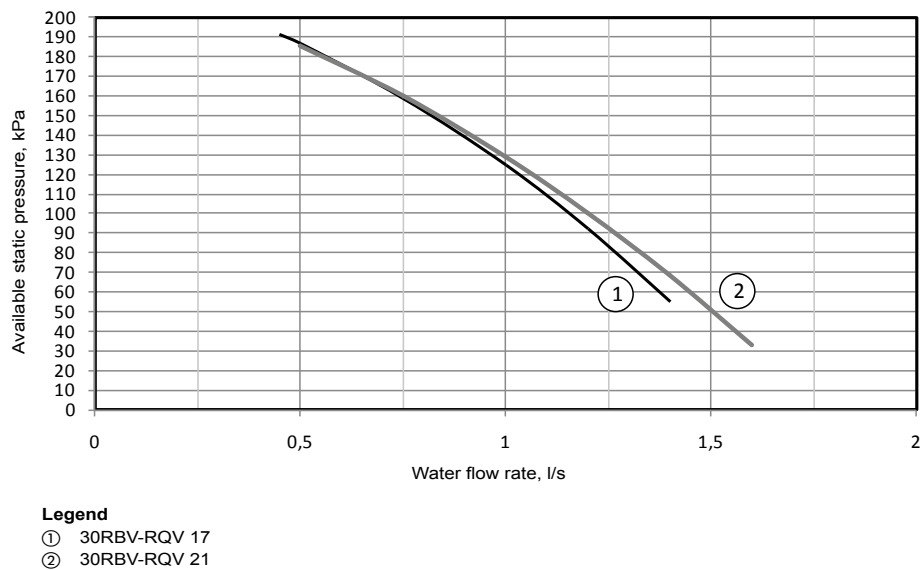

## 2 - INSTALLATION OF UNIT

**Graphic 3: Available external static pressure for 17kW unit with variable speed hydraulic module**

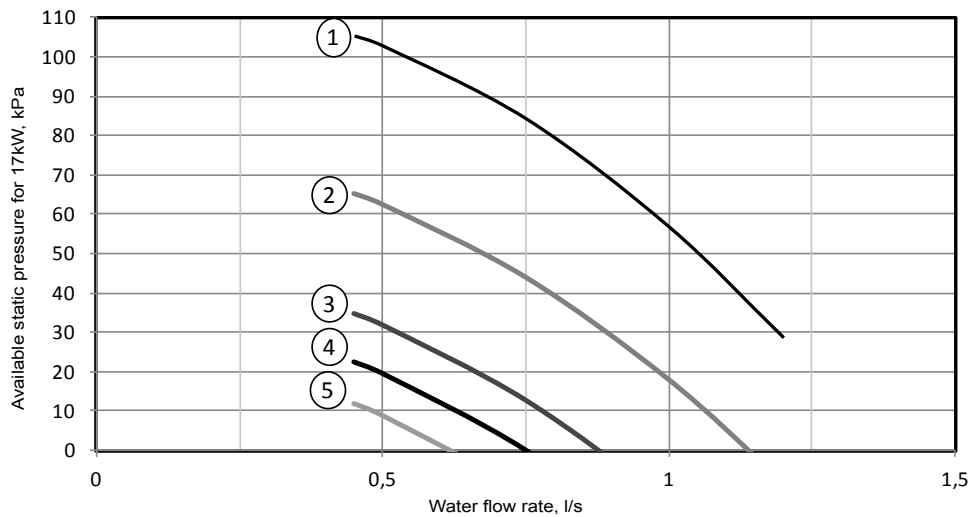

- Legend**
- ① Pump Speed = 100%
  - ② Pump Speed = 75%
  - ③ Pump Speed = 50%
  - ④ Pump Speed = 38%
  - ⑤ Pump Speed = 25%

**Graphic 4: Available external static pressure for 21kW unit with variable speed hydraulic module**

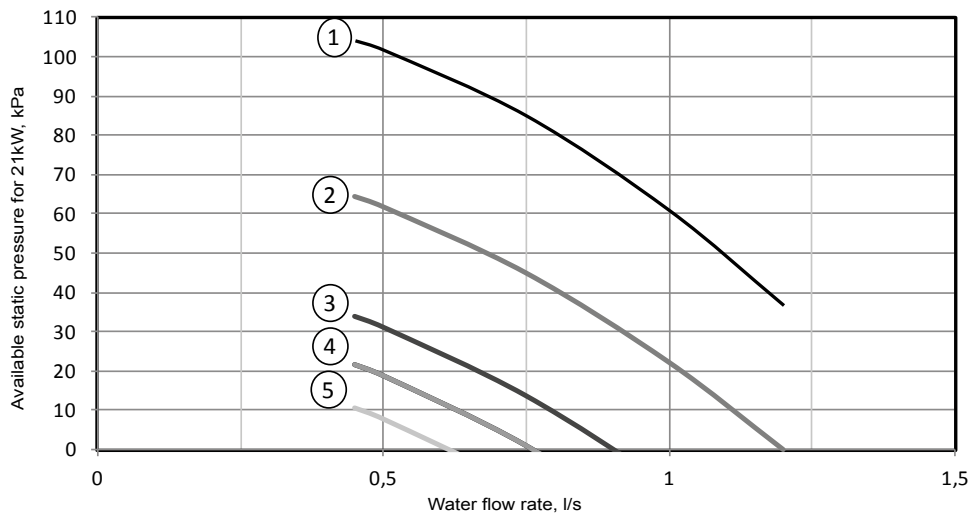

- Legend**
- ① Pump Speed = 100%
  - ② Pump Speed = 75%
  - ③ Pump Speed = 50%
  - ④ Pump Speed = 38%
  - ⑤ Pump Speed = 25%

## 2 - INSTALLATION OF UNIT

### 2.6 - Commissioning modes

**IMPORTANT:**

**Field connection of interface circuits may lead to safety risks: any control box modification must maintain equipment conformity with local regulations. Precautions must be taken to prevent accidental electrical contact between circuits supplied by different sources:**

- The routing selection and/or conductor insulation characteristics must ensure dual electric insulation.
- In case of accidental disconnection, conductor fixing between different conductors and/or in the control box prevents any contact between the conductor ends and an active energised part.

Refer to the 30RBV/30RQV 17-21 wiring diagram supplied with the unit for the field control wiring of the following features:

- Safety switch (normally close contact, mandatory)

**Three possible control configurations:**

**1/ Connections to the customer remote control (for more details, refer to Figure 13 and §4.2.4 Switches)**

- On/Off remote switch
- Heat/Cool select remote switch
- Home/Sleep select remote switch
- Alarm/Alert or Operation report...

**2/ Connections to the user interface**

When the unit-mounted user interface option is selected, the user interface is factory installed.

When the remote-mounted user interface accessory is chosen, the user interface has to be connected at the terminal block (refer to §3.9 Unit with remote user interface).

**NOTE:**

**It is not possible to have both local user interface and remote user interface on the same unit.**

**3/ Connections to the customer communication bus**

- The connection to the Proprietary Protocol is carried out using a connector provided for this purpose inside the control box. One connector is provided to allow service connection.
- Connection to the Jbus is made using a connector provided directly on the NHC electrical board (see the wiring diagram provided with the unit).

### 2.7 - Check before start the unit

Never be tempted to start the chiller without reading fully, and understanding, the operating instructions and without having carried out the following pre-start checks:

- Ensure that all electrical connections are properly tightened.
- Ensure that the unit is level and well-supported.
- Check that the hydraulic circuit has sufficient water flow and that the pipe connections correspond to the installation diagram.
- Ensure that there are no water leaks. Check the correct operation of the valves installed.
- All panels should be fitted and firmly secured with the corresponding screws.
- Make sure that there is sufficient space for servicing and maintenance purposes.
- Ensure that there are no refrigerant leaks.
- Confirm that the electrical power source agrees with the unit nameplate rating, wiring diagram and other documentation for the unit.
- Ensure that the power supply corresponds to the applicable standards.
- Make sure that compressors float freely on the mounting springs.

**CAUTION:**

- **Commissioning and start-up of the heat pump must be supervised by a qualified refrigeration qualified technician.**
- **Start-up and operating tests must be carried out with a thermal load applied and water circulating in the water heat exchanger.**
- **All set point adjustments and control tests must be carried out before the unit is started up.**

Ensure that all safety devices are operational, especially that the high pressure switches are functioning on and that any alarms are acknowledged.

**Note:**

**If the Manufacturer instructions (power and water connections and installation) are not observed, the Manufacturer warranty becomes invalid.**



### 3 - INSTALLATION OF SYSTEM

In this section, the general customer electrical connection is detailed as well as the main steps of configuration and examples of standard installation:

- Installation with booster electric heaters
- Installation with DHW production
- Installation with DHW production and boiler
- Master / Slave installation

Likewise the setpoint configuration with local and remote user interface is shown as well as the installation of additional OAT sensor and IAT sensor.

To obtain the list of all parameters, refer to §7.Parameter overview.

#### 3.1 - General customer electrical connection on terminal block

Figure 13: Customer electrical connection on terminal block

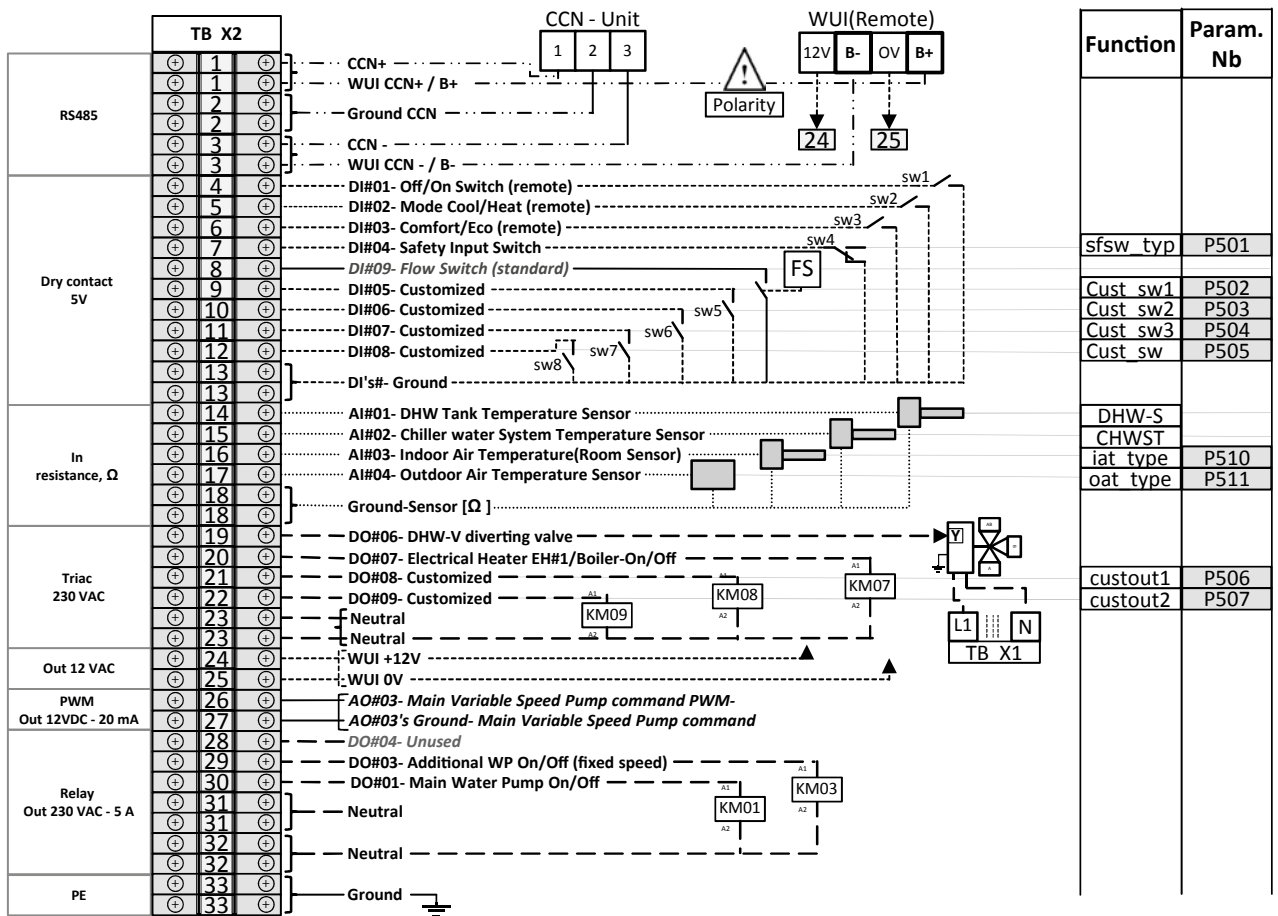

All customer wiring and devices have to be field provided & connected according to your system configuration.

# 3 - INSTALLATION OF SYSTEM

## 3.2 - First step of configuration: Setting the time and day

Before using any parameter menu of the WUI or Proprietary Protocol, it is necessary to set the time and day of the control.

N°	Steps	Table	Par.	Designation	Description	Range	Default	Ex.	Unit
1	Control of date and hour	UI_CONF	526	Interface Time Broadcast	0 = UI shall read the Date and Time in the Main Controller. 1 = UI shall broadcast Date and Time over the CCN bus.	0 to 1	1	0	-
2a	Set the day and hour	If unit is fitted with user interface, refer to WUI procedure below							
2b	Set the day and hour	If no user interface is available, enter date and hour using by Proprietary Protocol ([P661] to [P667] in Date & Time Table)							

The following sections explain the procedures for unit with user interface. If there is no user interface on the unit, it is necessary to use Customer communication bus (Proprietary Protocol or Jbus) to configure the unit.

To access the time configuration menu, press and hold the **Schedule** key for 2 seconds.

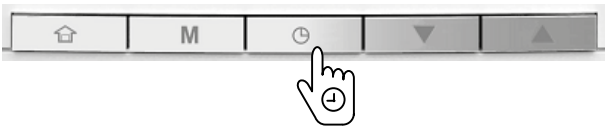

Press the **Schedule** key to confirm the time display.

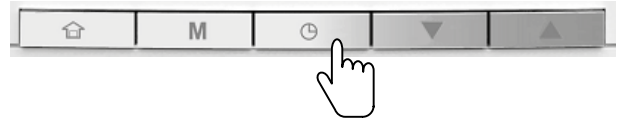

### 3.2.1 - Day of week setting

The current day starts flashing.



If necessary, **press** the **Down** key or the **Up** key to change the day of the week.



Press the **Schedule** key to confirm your selection and go to the next parameter.

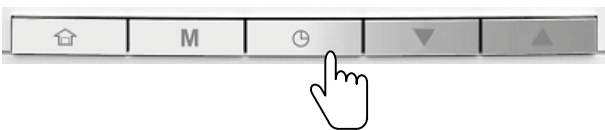

### 3.2.2 - Time format setting

Once the day of the week has been confirmed, set the time format. Press the **Down** key or the **Up** key to change the time format.



12-hour format



24-hour format

### 3.2.3 - Time setting

Once the time format has been confirmed, set the time.

Press the **Down** key or the **Up** key to set the time.



**For 24-hour format:** Set the hour and press the **Schedule** key to confirm. Then, set minutes and press the **Schedule** key to confirm.

To confirm all changes, press and hold the **Schedule** key for 2 seconds.

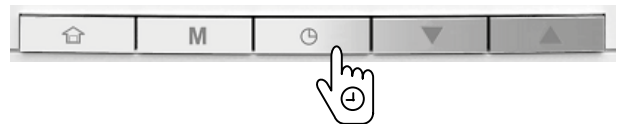

## 3.3 - Second step of configuration: Parameter menu

According to the application of unit, several parameters are to be configured to allow the correct operation of system. The following sections explain some standard cases of installation. But to configure the unit, it is necessary to access the parameter menu. If there is no user interface on the unit, it is necessary to use Customer communication bus (Proprietary Protocol or Jbus) to configure the unit. Otherwise in the case with user interface, follow the next procedure.

### 3.3.1 - To access the parameter menu

If the user interface is in standby mode, press one key to activate the WUI screen.

Press and hold the **Occupancy** key and the **Schedule** key simultaneously for 2 seconds.



The password screen is displayed.

### 3 - INSTALLATION OF SYSTEM

Figure 14: Password screen

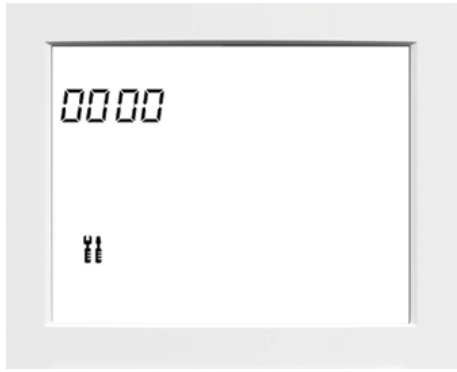

Enter the password: **0120**.

To change the number, press the **Up** or **Down** key.



To validate each number, press the **Schedule** key.

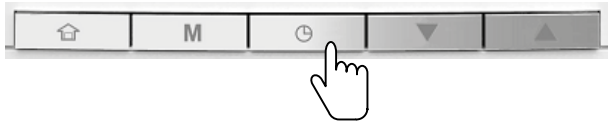

To validate the password and access parameter configuration, press and hold the **Mode** key for 2 seconds.

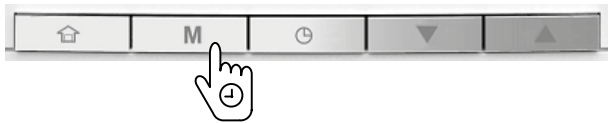

#### 3.3.2 - To navigate in the parameter menu

##### a - First possibility

Press and hold the **Up** or **Down** key.



Select the Parameter Number with the **Up** or **Down** key. Scroll until the required parameter is reached.



##### b - Second possibility

Press the **Up** or **Down** key until reach the required parameter.



#### 3.3.3 - To change a setting

Press and hold the **Schedule** key for 2 seconds.

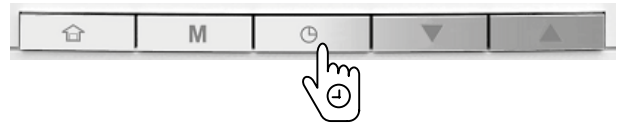

In the next sections, four standard installations are introduced, with for each example a hydraulic scheme, electrical connexion diagram and configuration steps.

To change the value of one digit, press the **Up** or **Down** key.



To validate each digit, press the **Schedule** key.

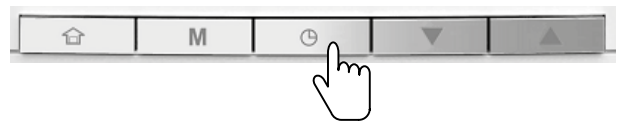

Repeat these steps for each digit of the setting.

When all the digits are selected and correct, press the **Mode** key to freeze the value.

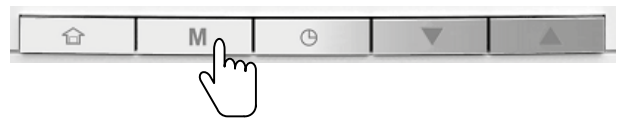

Next navigate through the parameter menu and configure all those necessary for the correct operation of the unit (refer to the following sections).

#### 3.3.4 - To exit the parameter menu







Press and hold the **Occupancy** key until the home screen is displayed.

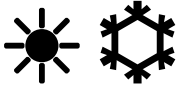
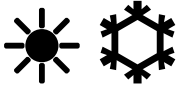
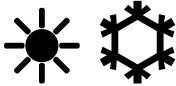
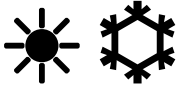
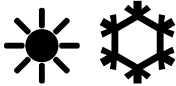

### 3 - INSTALLATION OF SYSTEM

#### 3.4 - Installation with booster electric heaters

This installation could be composed of:

	30RQV
	With integrated hydraulic kit (fixed speed or variable speed)
	Without integrated hydraulic kit
	Without User Interface
	With Local User Interface
	With Remote User Interface
	Cooling Mode
	Heating Mode
	Up to three booster electric heaters
	Available accessories (if ordered)
	Additional Outdoor Air Temperature Sensor

**IMPORTANT:**

For more information, refer to §4.2.11 Electric Heaters.

#### 3.4.1 - Standard installation

Figure 15: Standard installation with booster electric heaters

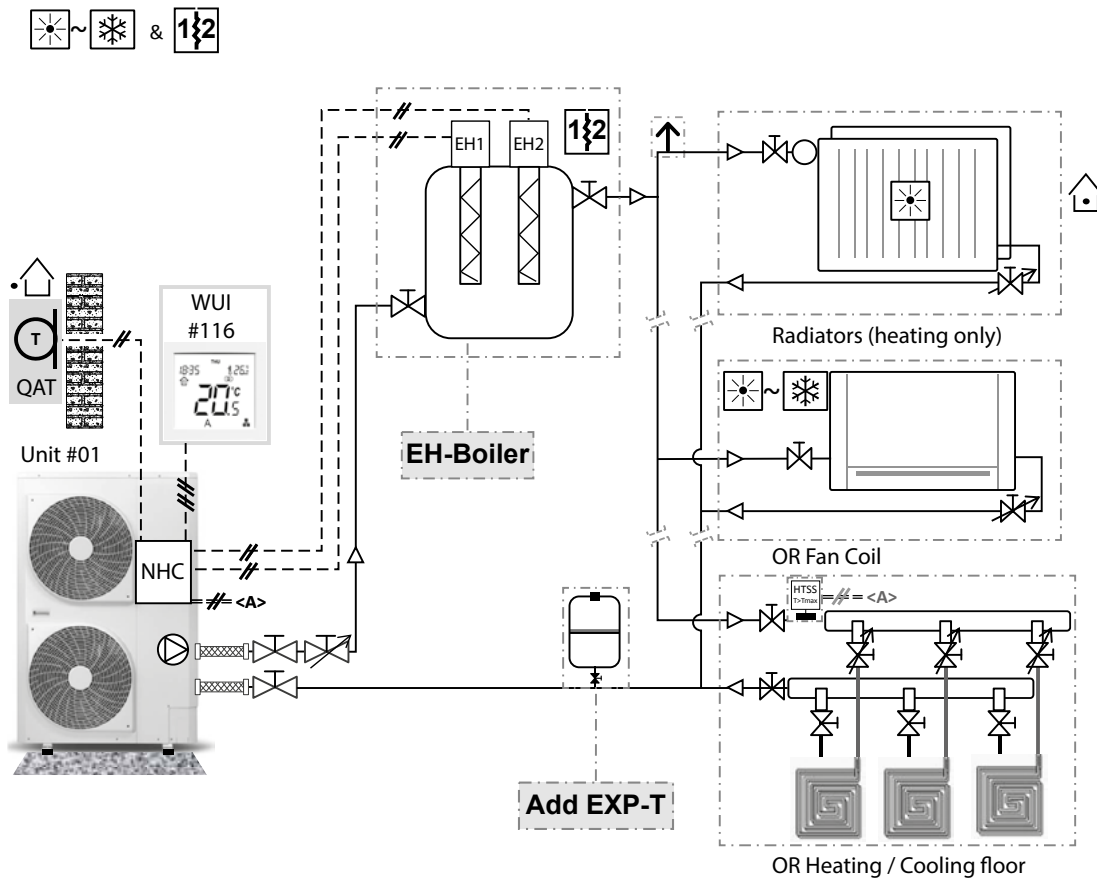

### 3 - INSTALLATION OF SYSTEM

#### 3.4.2 - Electrical connection

Figure 16: Electrical connection on terminal block for booster electric heaters

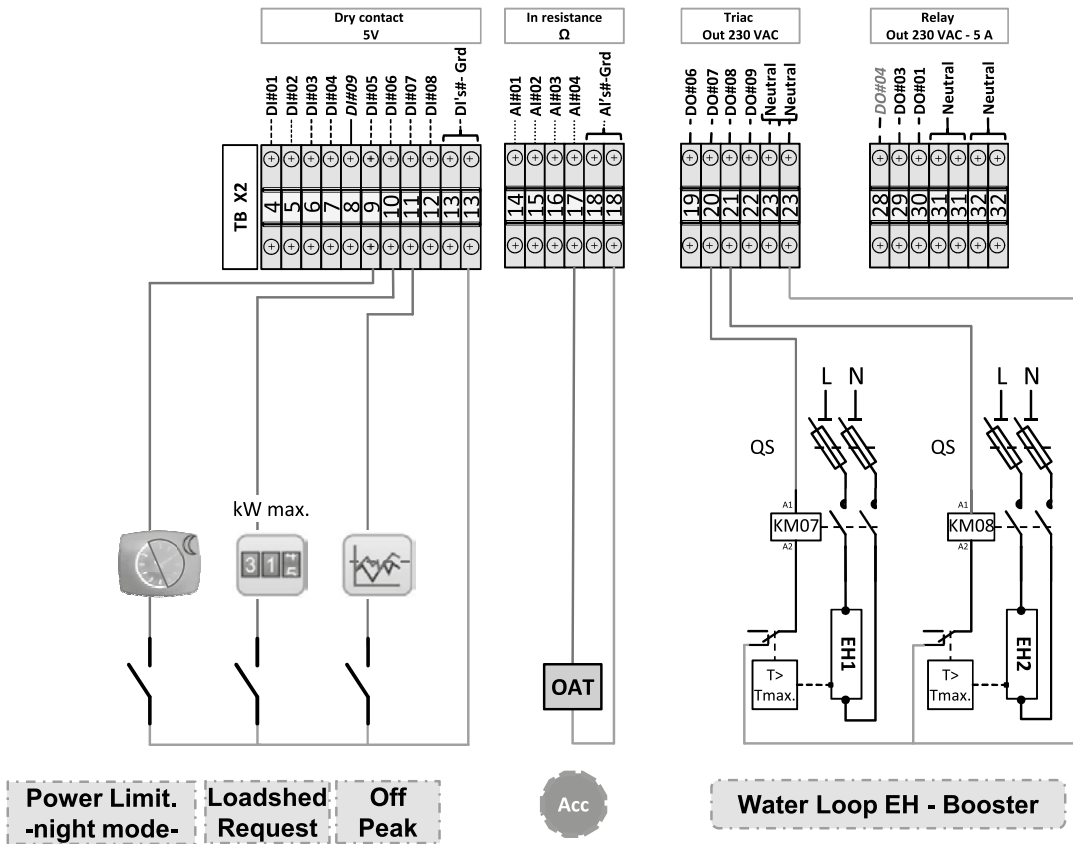

### 3 - INSTALLATION OF SYSTEM





#### 3.4.3 - Control configuration steps

N°	Steps	Table	Par.	Designation	Description	Range	Default	Ex.	Unit
1	Set Booster stages	BCK_CONF	601	Backup Type	0 = No backup 1 = Booster by 1 Electric Heat Stage (EH1) 2 = Booster by 2 Electric Heat Stages (EH1/EH2) 3 = Booster by 3 Electric Heat Stages with 2 outputs (EH1/EH2) 4 = Booster by 3 Electric Heat Stages with 3 outputs (EH1/EH2/EH3) 5 to 9 = not used for this configuration	0 to 9	0	3	-
			602	Booster Warm up Timer	Once the unit has started, if after this timer has expired the capacity demand is at maximum and the setpoint isn't reached, then the booster is activated	5 to 120	30	20	min
			604	Booster OAT Threshold	Booster heating is allowed to run if OAT goes below this threshold (with 1 K hysteresis).	-30.0 to 15.0	-7.0	2	°C
		GEN_CONF	506	Customized DO #9 Config	0 = Disabled 10 = Electrical heat stage #2 11 = Electrical heat stage #3 1 to 9 and 12 - 13 = not used for this configuration	0 to 13	1	10	-
First possibility: If <b>no internal pump</b> (unit version 30 RQV 021 n X) is fitted in the unit, it is possible to use the unit to control an external pump.									
2a	Control an external pump on unit logic	PUM_CONF	561	External Main Pump Control	If no pump or circulator is fitted in the unit, it is possible to control an external pump	0 to 1	0	1	-
2b	Second possibility: If <b>internal pump = fixed speed pump</b> (unit version 30 RQV 021 n H ; F ; R ; Z) is present in the unit. If internal pump is <b>fixed speed</b> , there is no need to configure (already factory configured)								
2c	Third possibility: If <b>internal pump = variable speed pump</b> (unit version 30 RQV 021 n M ; N ; P ; Q) fitted in the unit. If internal pump is variable speed, then some parameters need to be configured (refer to §2.5.5. Nominal system water flow control)								
3	Advanced settings Pump configuration (common to no internal pump / with internal pump fixed or variable)	PMP_CONF	563	Anti-sticking function	The pump is started and to run for 30 seconds provided that it has been inactive for 24 hours. Starting the pump regularly increases the lifetime of the pump.	0 to 1	1	1	-
		PMP_CONF	565	Main Pump Logic	If no user interface or local user interface This parameter defines the Main Pump functioning in Standby Mode: 1 = Always On 2 = Water Sampling (On/Off according to [P564]) 3 = not used for this configuration	1 to 3	1	2	-
		PMP_CONF	564	Pump Sampling Time Sdby	If no user interface or local user interface and [P565] = 2 5 to 240 = In Standby (satisfied), pump is running every x minutes (for 2 minutes) in order to get a correct refreshed Water Control Temperature measurement.	5 to 240	15	120	min
		PMP_CONF	565	Main Pump Logic	If Remote user interface or IAT sensor This parameter defines the Main Pump functioning in Standby Mode: 1 = Always On 3 = According to Space Temp 2 = not used for this configuration	1 to 3	1	3	-

### 3 - INSTALLATION OF SYSTEM

#### 3.5 - Installation with DHW production

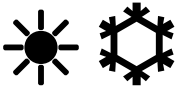
This installation could be composed of:

	30RQV
	With integrated hydraulic kit (fixed speed or variable speed) Without integrated hydraulic kit
	Without User Interface With Local User Interface With Remote User Interface
	Cooling Mode Heating Mode
	DHW production
Available accessories (if ordered)	Additional Outdoor Air Temperature Sensor DHW sensor

**IMPORTANT:**

For more information on DHW mode and DHW sensor accessory, refer to § 4.2.8 Domestic hot water mode.

#### 3.5.1 - Standard installation

Figure 17: Standard installation with DHW production

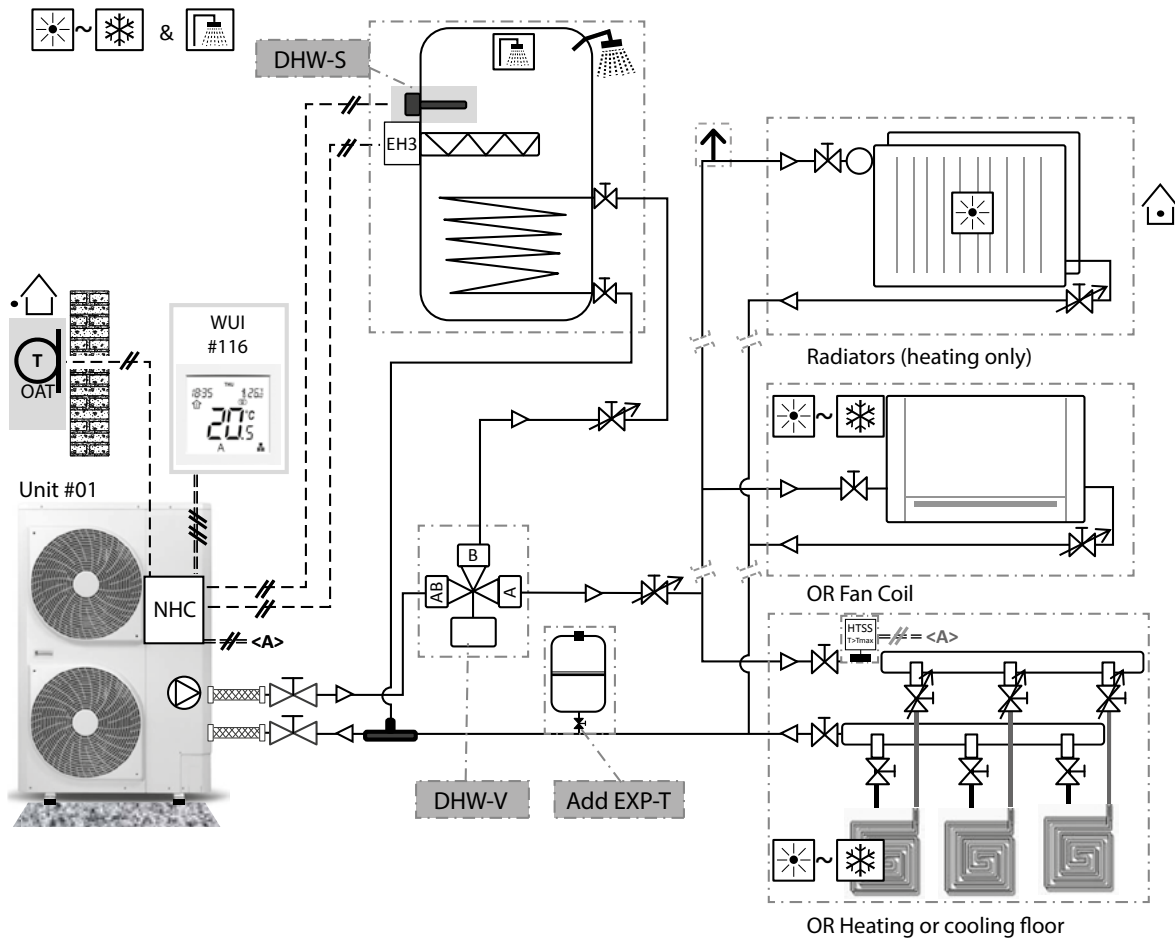

### 3 - INSTALLATION OF SYSTEM

#### 3.5.2 - Electrical connection

Figure 18: Electrical connection on terminal block for DHW production

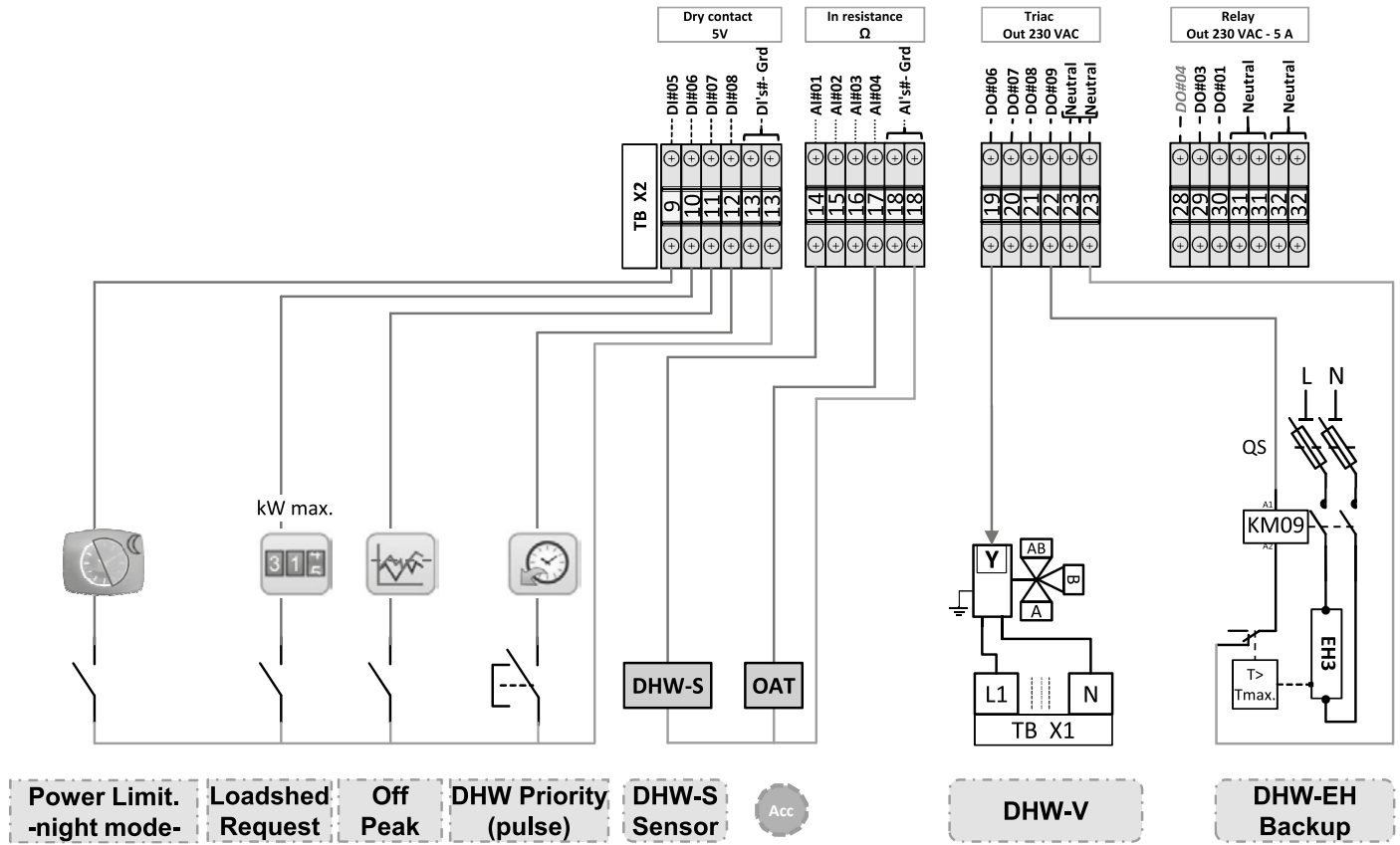

#### 3.5.3 - Control configuration steps

N°	Steps	Table	Par.	Designation	Description	Range	Default	Ex.	Unit
1	Configure the DHW mode	DHW_CONF	701	Domestic Hot Water Type	0 = No DHW management 1 = Diverting Valve 2-points - NO contact (valve energized in DHW position) 2 = Diverting Valve 2-points - NC contact (valve de-energized in DHW position) 3 = not used	0 to 3	0	1	-
			719	DHW Tank Sensor Type	0 = DHW Thermostat (thermal switch) 1 = DHW Sensor (thermistor 10 KΩ) 2 = DHW Sensor (thermistor 5 KΩ) 3 = DHW Sensor (thermistor 3 KΩ) Note: If no sensor is selected ("0"), the DHW Request is always true and the function of switching back to Space Heating/Cooling is managed by timers.	0 to 3	0	1	-
2	Set the pump speed for DHW mode only	QCK_TEST	321	Quick Test enable	Access to Quick test mode	0 to 1	0	1	-
			331	Water Pump Speed	Adjust water pump speed to obtain the expected flow rate for DHW hydraulic circuit	0 to 100	0	?	%
			331	Water Pump Speed	When the pump speed is identified, stop the pump.	0 to 100	0	0	%
			321	Quick Test enable	Exit the quick mode	0 to 1	0	0	-
		PUM_CONF	710	Pump Speed in DHW	Set the pump speed identified in last step in DHW mode.	19 to 100	100	Enter pump speed determined at last step [P331]	%
3	Configure the DHW setpoint	WAT_STP	406	DHW Setpoint	DHW setpoint	30.0 to 60.0	50	55	°C
			405	DHW Anti-Legionella Stp	Anti-Legionella Water Setpoint	50.0 to 60.0	60	60	°C



### 3 - INSTALLATION OF SYSTEM

N°	Steps	Table	Par.	Designation	Description	Range	Default	Ex.	Unit	
4	Set Backup heater inside the water tank	GEN_CONF	507	Customized DO #10 Config	0 = Disabled 10 = Electrical heat stage #2 11 = Electrical heat stage #3 1 to 9 and 12 - 13 = not used for this configuration	0 to 13	1	11	-	
			BCK_CONF	601	Backup Type	0 = No backup 5 = DHW Backup (EH3) 6 = Boosterd by 1 Electric Heat Stage (EH1) + DHW Backup (EH3) 7 = Boosterd by 2 Electric Heat Stages (EH1/EH2) + DHW Backup (EH3) 8 = Boosterd by 3 Electric Heat Stages with 2 outputs (EH1/EH2) + DHW Backup (EH3) 1 to 4 and 9 = not used for this configuration	0 to 9	0	5	-
				604	Booster OAT Threshold	The booster heating is allowed to run if OAT goes below this threshold (with 1 K hysteresis).	-30.0 to 15.0	-7.0	2	°C
5	Configure DHW Schedule	DHW_CONF	711	DHW Schedule Days	Select the days for the operation in DHW mode Monday / Tuesday / Wednesday / Thursday / Friday / Saturday / Sunday	Yes / No Without WUI 0000 0000 to 1111 1110 <sup>(1)</sup>	Yes	Yes	-	
			712	DHW Starting Time	Hour of starting up of DHW mode	00:00 to 23:59	21:00	07:00	hh:mm	
			713	DHW Stopping Time	Hour of stop of DHW mode	00:00 to 23:59	06:00	22:00	hh:mm	
6	Configure Anti-legionella Schedule	DHW_CONF	714	Anti-legionella Strt DOW	Select the days for the operation in Anti-legionella mode Monday / Tuesday / Wednesday / Thursday / Friday / Saturday / Sunday	Yes / No Without WUI 0000 0000 to 1111 1110 <sup>(1)</sup>	No	No	-	
			715	Anti-legionella Strt Time	Hour for start of Anti-legionella mode	00:00 to 23:59	02:00	05:00	hh:mm	
7	Set criteria of start / stop of DHW	DHW_CONF	721	DHW Tank Delta T (start)	DHW Mode is requested if Tank Water Temperature goes below DHW Setpoint [P406] minus DHW Tank Delta T [P721](start).	2.0 to 10.0	5	6	K	
			722	EWT Delta T (stop)	DHW Mode is stopped if EWT goes above DHW Setpoint [P406] minus EWT Delta T [P722](stop DHW).	0.0 to 20.0	10	15	K	
8	Configure the operating time between the DHW mode and the Space Heating / Cooling mode	DHW_CONF	704	SHC Minimum Runtime	Minimum time of operation in SHC mode	0 to 720	20	20	min	
			707	DHW Maximum Runtime	Maximum time of operation at DHW mode If this parameter is configured to -1, DHW Runtime is ignored.	-1 to 720	60	60	min	
9	Configure Summer mode	DHW_CONF	716	Summer Mode OAT Thrshold	The summer mode is set when the Summer Mode switch is closed.	15.0 to 30.0	20	22	°C	
			717	Summer Mode On Delay	• Summer Mode is set to ""On"" if OAT is above Summer Mode OAT Threshold [P716] for at least the Summer Mode On Delay [P717].	0 to 12	0	7	h	
			718	Summer Mode Off Delay	• Summer Mode is reset if OAT goes below Summer Mode OAT Threshold [P716] minus 2 K for at least the Summer Mode Off Delay [P718].	0 to 12	0	7	h	
10	Set the DHW limitation mode	CMP_CONF	543	DHW Mode Limit value	The compressor frequency is limited to this percentage of the maximum allowed frequency when running in Domestic Hot Water Mode.	50 to 100	100	75	%	
11	If an additional pump is installed, refer to § 3.6 Installation with DHW production and boiler for configuration									

(1) b7 b6 b5 b4 b3 b2 b1 b0





b7: Monday  
b6: Tuesday  
b5: Wednesday  
b4: Thursday  
b3: Friday  
b2: Saturday  
b1: Sunday  
b0: unused

Example: If value "1111 1110" is set, the DHW will be started each and every day.

### 3 - INSTALLATION OF SYSTEM

#### 3.6 - Installation with DHW production and boiler

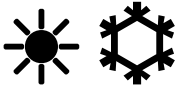
This installation could be composed of:

	30RQV
	With integrated hydraulic kit (fixed speed or variable speed) Without integrated hydraulic kit
	Without User Interface With Local User Interface With Remote User Interface
	Cooling Mode Heating Mode
	DHW production
	Boiler
Available accessories (if ordered)	Additional Outdoor Air Temperature Sensor DHW sensor

**IMPORTANT:**

*For more information, refer to § 4.2.8 Domestic hot water mode. and § 4.2.12 Boiler.*

# 3 - INSTALLATION OF SYSTEM

## 3.6.1 - Standard installation

Figure 19: Standard installation with DHW production and boiler

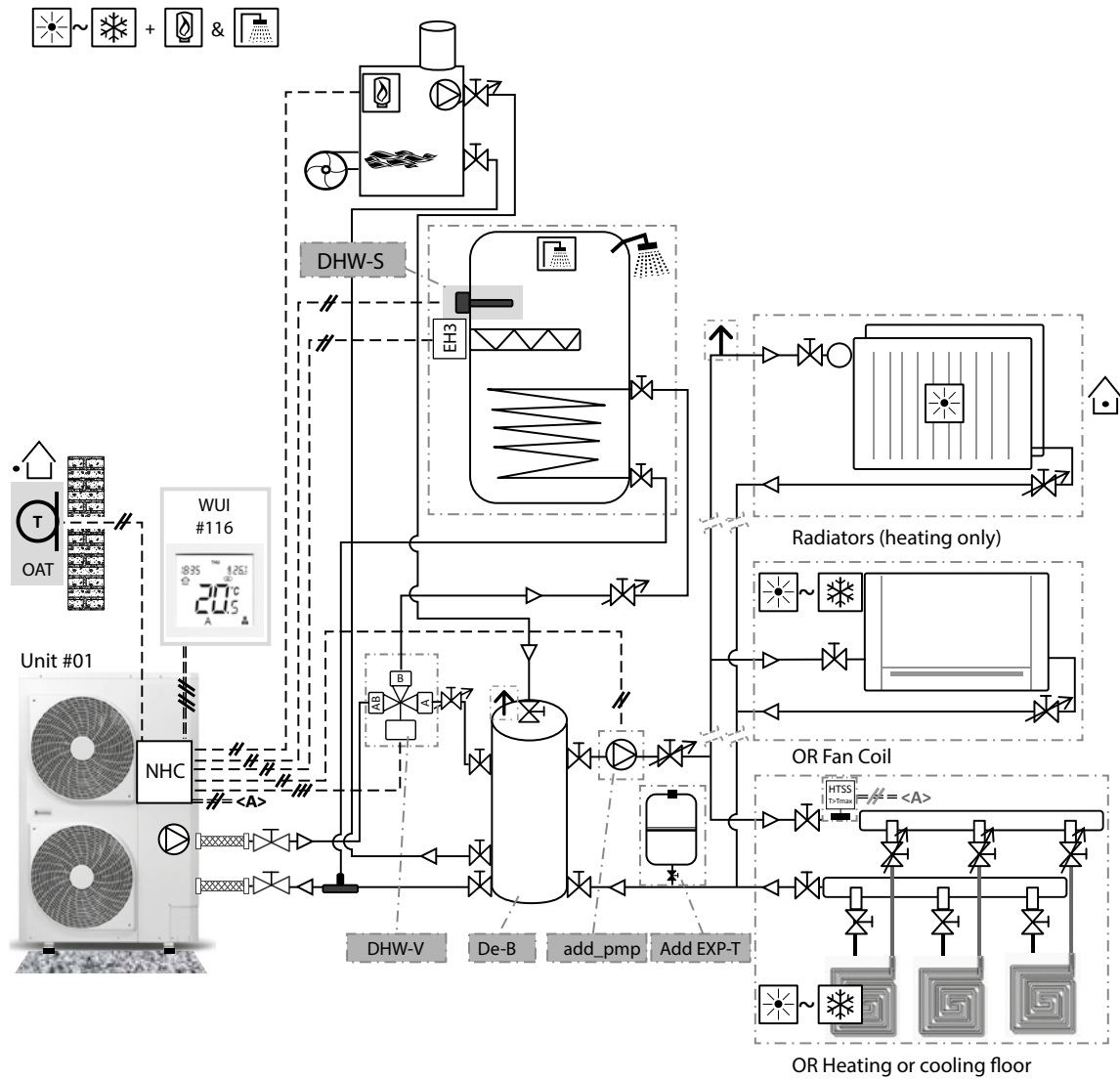

## 3.6.2 - Electrical connection

Figure 20: Electrical connection on terminal block for DHW production and boiler

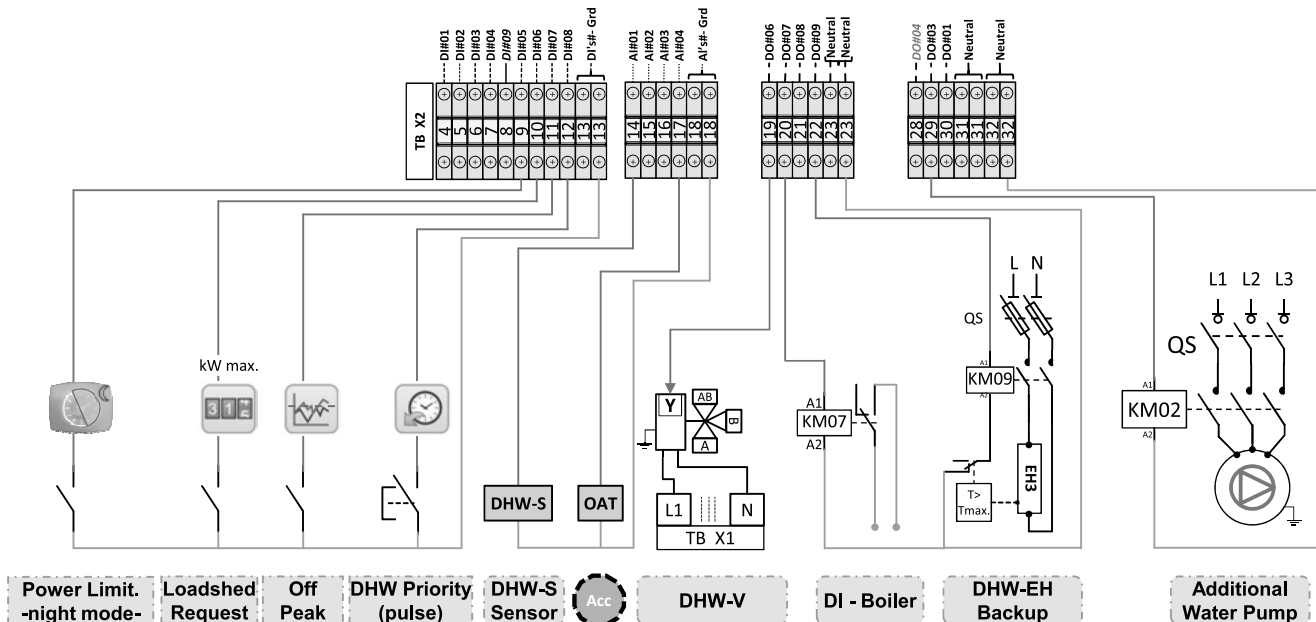









## 3 - INSTALLATION OF SYSTEM

### 3.6.3 - Control configuration steps

N°	Steps	Table	Par.	Designation	Description	Range	Default	Ex.	Unit
1	Configure the DHW mode				Refer to §3.5. Installation with DHW production				
2	Set a Boiler	BCK_CONF	601	Backup Type	0 = No backup 9 = Backup by Oil or Gas Boiler 1 to 8 = not used for this configuration	0 to 9	0	9	-
			514	Minimum OAT for Heating	The Heat Pump is not allowed to run in Heating if the OAT goes below this threshold.	-20.0 to 10.0	-20.0	-7	°C
3	Set an additional pump	PMP_CONF	573	Additional Pump Logic	If no user interface or local user interface This parameter defines the Additional Pump functioning in Standby Mode: 0 = No additional Pump 1 = Always On except in Off Mode 3 = Always On, except in Off Mode or when DHW Mode is active. 2 and 4 = not used for this configuration	0 to 4	0	Refer to §4.2.10. Pump configuration	-
					If Remote user interface or IAT sensor This parameter defines the Additional Pump functioning in Standby Mode: 0 = No additional Pump 2 = According to Space Temp : Pump off except when there is a demand from the room temperature 4 = Pump off except when there is a demand from the room temperature and no DHW is active 1 and 3 = not used for this configuration	0 to 4	0	Refer to §4.2.10. Pump configuration	-

### 3.7 - Master / Slave installation

This installation could be composed of:

	30RBV
	30RQV
	(same type / same size for one Master / Slave installation)
	With integrated hydraulic kit:
	- fixed speed
	- variable speed (no ΔT logic)
	Master unit fitted with local or remote user interface
	No user interface on slave units
	Cooling Mode
	Heating Mode
	(according unit type)
	Available accessories (if ordered)
	Master / Slave leaving water temperature sensor (to be connected only on Master unit)
	Additional Outdoor Air Temperature Sensor (to be connected only on Master unit)

#### **IMPORTANT:**

**For more information, refer to § 4.2.9 Master / Slave up to 4 units.**

### 3 - INSTALLATION OF SYSTEM

#### 3.7.1 - Standard installation

Figure 21: Standard installation with Master / Slave (example with 3 slaves)

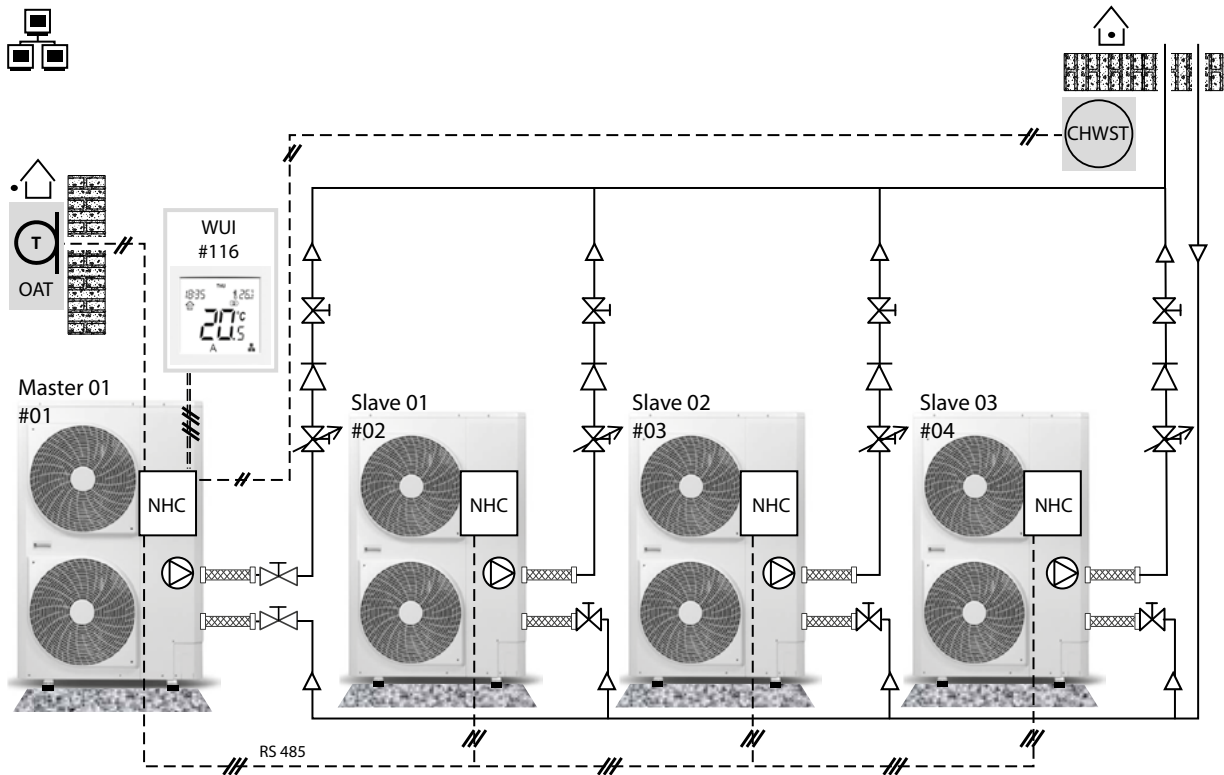

#### 3.7.2 - Electrical connection

Figure 22: Electrical connection on terminal block for Master / Slave installation

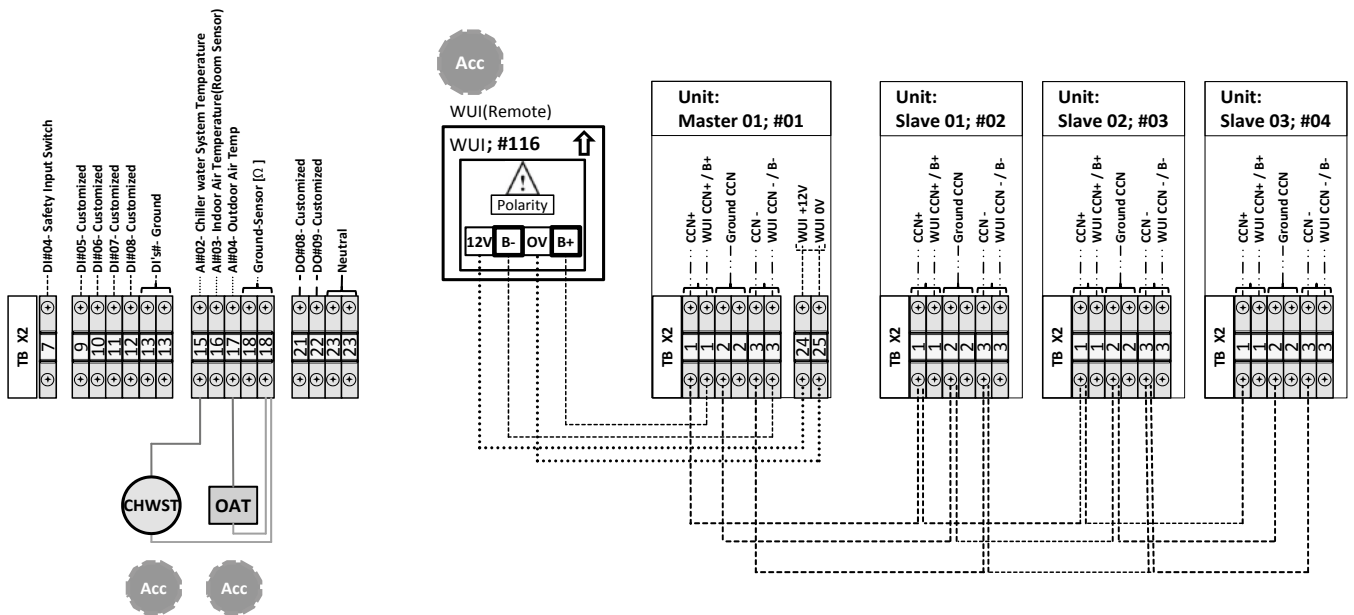

### 3 - INSTALLATION OF SYSTEM

#### 3.7.3 - Control configuration steps

##### a - Configuration steps: one master and two slaves with one user interface on master

N°	Steps	Figure	Table	Par.	Designation	Description	Range	Default	Ex.	Unit	
1	Change Slave 2 NHC address to 3		30RBV/RQV	641	CCN Element Address	For master unit with a WUI, to address the different units of master/slave installation, it is necessary to disconnect RS485 bus (Green connector J6) from Master and all Slaves <b>except the last one</b> . But WUI is switched on by master unit (12VDC)	0 to 239	0	3	-	
						It is necessary to set the NHC board address of Slave 2 different as NHC board address of Master					
Wait 30s before next step. An error can appear on WUI screen, but it is not a problem to continue the configuration.											
2	Change Slave 1 NHC address to 2		30RBV/RQV	641	CCN Element Address	Connect the RS485 bus (Green connector J6) on Slave 1, besides Slave 2	0 to 239	0	2	-	
						It is necessary to set the NHC board address of Slave 1 different as NHC board address of Master					
Wait 30s before next step. An error can appear on WUI screen, but it is not a problem to continue the configuration.											
3	Configure Master board		MSL_CONF	743	Slave #1 Address	It is necessary to set the Slave address different as Master address	0 to 239	0	2	-	
					744	Slave #2 Address					It is necessary to set the Slave address different as Master address
					742	Master/Slave Selection					Allow the Master/Slave operation as Master: 0 = Disable 1 = Master 2 = Slave
4	Compressor Control method choice		MSL_CONF	751	Cascade Type	The cascade type configuration refers to the control of master / slave operation. 0 = Starting Master First, then first Slave to last Slave. Stopping Last Slave to first Slave, then Master. 1 = Starting/stopping units according to their wear factors. 2 = All units (Master and Slaves) are started/stopped at the same time.	0 to 2	1	1	-	
						746					Capa. to Start Next Unit
5	Configure Slave 1		MSL_CONF	742	Master/Slave Selection	Apply procedure §3.7.3.b-Manage the Master and Slave units with a common user interface to pass on Slave 1 status	0 to 2	0	2	-	
						UI_CONF					521
6	Configure Slave 2		MSL_CONF	742	Master/Slave Selection	Apply procedure § 3.7.3.b-Manage the Master and Slave units with a common user interface to pass on Slave 2 status	0 to 2	0	2	-	
						UI_CONF					521

### 3 - INSTALLATION OF SYSTEM

N°	Steps	Figure	Table	Par.	Designation	Description	Range	Default	Ex.	Unit
7	Main Variable speed pump configuration for Master/Slave installation		MSL_CONF	758	Master/ Slave Pump Type	<p>If the units are fitted with internal main variable speed pump, then several parameters are to set for each unit of Master / Slave installation</p> <p>To configure main pump of Master unit, the other units of installation must be in mode OFF (only Master unit is activated)</p> <p>Apply procedure § 3.7.3.b-Manage the Master and Slave units with a common user interface to pass on Master status</p>	0 to 3	2	2	-
						<p>Determine the min pump speed to allow closure of flow switch (refer to Table 3: Actions in WUI parameter menu or Service tools to activate the cleaning purge and control of flow rate for hydraulic circuit)</p> <p>Adjust pump speed to obtain the expected water flow rate (refer to Table 3: Actions in WUI parameter menu or Service tools to activate the cleaning purge and control of flow rate for hydraulic circuit - Line 'Variable speed pump – control on adjustable constant speed')</p>				
						<p>If the units are fitted with internal main variable speed pump, then several parameters are to set for each unit of Master / Slave installation</p> <p>To configure main pump of Master unit, the other units of installation must be in mode OFF (only Master unit is activated)</p> <p>Apply procedure § 3.7.3.b-Manage the Master and Slave units with a common user interface to pass on Master status</p>	0 to 3	2	2	-
						<p>Determine the min pump speed to allow closure of flow switch (refer to Table 3: Actions in WUI parameter menu or Service tools to activate the cleaning purge and control of flow rate for hydraulic circuit)</p> <p>Adjust pump speed to obtain the expected water flow rate (refer to Table 3: Actions in WUI parameter menu or Service tools to activate the cleaning purge and control of flow rate for hydraulic circuit - Line 'Variable speed pump – control on adjustable constant speed')</p>				
						<p>To configure main pump of Slave 1 unit, the other units of installation must be in mode OFF (only Slave 1 is activated)</p> <p>Apply procedure §3.7.3.b-Manage the Master and Slave units with a common user interface to pass on Slave 1 status</p>	0 to 3	2	2	-
						<p>Determine the min pump speed to allow closure of flow switch (refer to Table 3: Actions in WUI parameter menu or Service tools to activate the cleaning purge and control of flow rate for hydraulic circuit)</p> <p>Adjust pump speed to obtain the expected water flow rate, with pump logic = adjustable constant speed (refer to Table 3: Actions in WUI parameter menu or Service tools to activate the cleaning purge and control of flow rate for hydraulic circuit - Line 'Variable speed pump – control on adjustable constant speed')</p>				
			MSL_CONF	758	Master/ Slave Pump Type	<p>To configure main pump of Slave 1 unit, the other units of installation must be in mode OFF (only Slave 1 is activated)</p> <p>Apply procedure §3.7.3.b-Manage the Master and Slave units with a common user interface to pass on Slave 1 status</p>	0 to 3	2	2	-
						<p>Determine the min pump speed to allow closure of flow switch (refer to Table 3: Actions in WUI parameter menu or Service tools to activate the cleaning purge and control of flow rate for hydraulic circuit)</p> <p>Adjust pump speed to obtain the expected water flow rate, with pump logic = adjustable constant speed (refer to Table 3: Actions in WUI parameter menu or Service tools to activate the cleaning purge and control of flow rate for hydraulic circuit - Line 'Variable speed pump – control on adjustable constant speed')</p>				
						<p>To configure main pump of Slave 2 unit, the other units of installation must be in mode OFF (only Slave 2 is activated)</p> <p>Apply procedure §3.7.3.b-Manage the Master and Slave units with a common user interface to pass on Slave 2 status</p>	0 to 3	2	2	-
						<p>Determine the min pump speed to allow closure of flow switch (refer to Table 3: Actions in WUI parameter menu or Service tools to activate the cleaning purge and control of flow rate for hydraulic circuit)</p> <p>Adjust pump speed to obtain the expected water flow rate, with pump logic = adjustable constant speed (refer to Table 3: Actions in WUI parameter menu or Service tools to activate the cleaning purge and control of flow rate for hydraulic circuit - Line 'Variable speed pump – control on adjustable constant speed')</p>				
						<p>To configure main pump of Slave 2 unit, the other units of installation must be in mode OFF (only Slave 2 is activated)</p> <p>Apply procedure §3.7.3.b-Manage the Master and Slave units with a common user interface to pass on Slave 2 status</p>	0 to 3	2	2	-
						<p>Determine the min pump speed to allow closure of flow switch (refer to Table 3: Actions in WUI parameter menu or Service tools to activate the cleaning purge and control of flow rate for hydraulic circuit)</p> <p>Adjust pump speed to obtain the expected water flow rate, with pump logic = adjustable constant speed (refer to Table 3: Actions in WUI parameter menu or Service tools to activate the cleaning purge and control of flow rate for hydraulic circuit - Line 'Variable speed pump – control on adjustable constant speed')</p>				

8 The master unit is then used for all the other configuration points (setpoint...). To know the status of different Slaves, follow the procedure below (refer to § 3.7.3. b-Manage the Master and Slave units with a common user interface).

### 3 - INSTALLATION OF SYSTEM

#### b- Manage the Master unit and Slave units with a common user interface

Thanks to common user interface on the master unit, it is possible to access data of slaves (main screen, parameter menu...).

The procedure to navigate between the different general status of units and pass from Master to Slave 1, then to Slave 2 (if existing), then to Slave 3 (if existing), is the following:

To navigate from Master to Slave or Slave to Slave, press and hold the **Occupancy** key and **Up** key simultaneously for 2 seconds.



Figure 23: WUI screen for Slave 1

From this screen, it is possible to access all data of Slave 1 (parameter menu...).

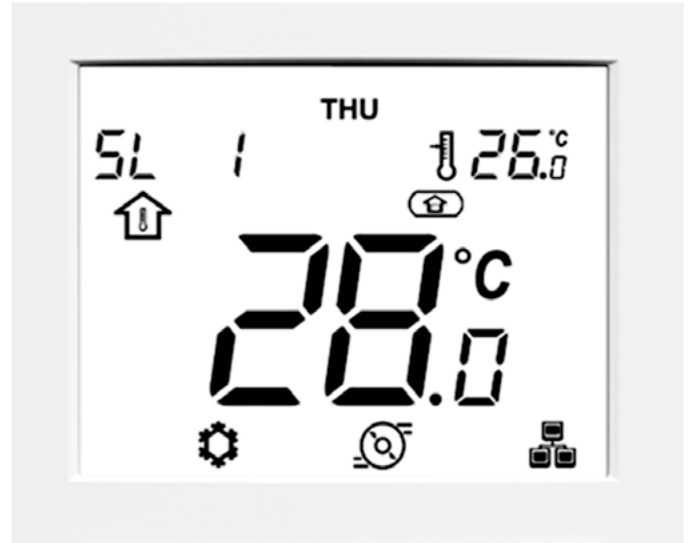

To finish the commissioning, it is necessary to configure setpoint according to the user interface configuration

#### 3.8 - Unit without WUI or with local WUI

To use this procedure, the unit must:

- either be fitted with local user interface,
- or have any user interface,
- and have any IAT sensor.

**IMPORTANT:**

For more information on how to use this user interface, please refer to WUI end user manual. And for more details on the setpoint control, refer to §4.2.5 Setpoint.

##### 3.8.1 - Control configuration steps

N°	Steps	Table	Par.	Designation	Description	Range	Default	Ex.	Unit	Access	Check
1	Check that the unit is configured in Local Interface or no user interface	UI_CONF	521	User Interface Type	0 = No User Interface 1 = Remote control by contacts or SUI 2 = WUI remotely installed in the house 3 = WUI locally installed on the unit	0 to 3	0	3	-		✓
Check on WUI screen that the unit is configured in Water setpoint											
2a	First possibility: control on predefined climatic curve	CLIMCURV	581	Heat Clim Curv Select	0 = No Curve / Fixed Water Setpoint 1 to 12 = Heating Climatic Curve #number 13 = Custom Climatic Curve	-1 to 12	-1	2	-		
402			Heat Sleep Offset	Water offset for heating mode when Occupancy mode = Sleep	-10.0 to 0.0	0.0	-5	^C			
403			Heat Away Offset	Water offset for heating mode when Occupancy mode = Away	-10.0 to 0.0	-5.0	-10	^C			
412			Heat Curv Max Stp Offset	Heat Maximum Water Setpoint can be offseted by this parameter, to adjsut at best the setpoint at customer needs	-5.0 to 5.0	0	5	^C			
586			Cool Clim Curv Select	0 = No Curve / Fixed Water Setpoint 1 to 2 = Cooling Climatic Curve #1number 3 = Custom Climatic Curve	-1 to 2	-1	1	-			
408			Cool Sleep Offset	Water offset for cooling mode when Occupancy mode = Sleep	0.0 to 10.0	0	2	^C			
409			Cool Away Offset	Water offset for cooling mode when Occupancy mode = Away	0.0 to 10.0	5	5	^C			
413			Cool Curve Min Stp Offset	Cool Minimum Water Setpoint can be offseted by this parameter, to adjsut at best the setpoint at customer needs	-5.0 to 5.0	0	5	^C			



### 3 - INSTALLATION OF SYSTEM

N°	Steps	Table	Par.	Designation	Description	Range	Default	Ex.	Unit	Access	Check
2b	Second possibility: control on fixed LWT setpoint	WAT_STP	581	Heat Clim Curv Select	Heating climatic curve select	-1 to 12	-1	-1	-		✓
			401	Heat Home Setpoint	Water setpoint for heating mode when Occupancy mode = Home	20.0 to 60.0	45	50	°C		
			402	Heat Sleep Offset	Water offset for heating mode when Occupancy mode = Sleep	-10.0 to 0.0	0.0	-5	^C		
			403	Heat Away Offset	Water offset for heating mode when Occupancy mode = Away	-10.0 to 0.0	-5.0	-10	^C		
			586	Cool Clim Curv Select	Cooling climatic curve select	-1 to 2	0	-1	-		✓
			407	Cool Home Setpoint	Water setpoint for cooling mode when Occupancy mode = Home	0.0 to 18.0	12	18	°C		
			408	Cool Sleep Offset	Water offset for cooling mode when Occupancy mode = Sleep	0.0 to 10.0	0	2	^C		
			409	Cool Away Offset	Water offset for cooling mode when Occupancy mode = Away	0.0 to 10.0	5	5	^C		
2c	Third possibility: control on customer climatic curve	CLIMCURV	581	Heat Clim Curv Select	Heating climatic curve select	-1 to 12	-1	0	-		
			582	Heat Minimum OAT	In heating mode, Customer minimum OAT	-30.0 to 10.0	-7.0	-20	°C		
			583	Heat Maximum OAT	In heating mode, Customer maximum OAT	10.0 to 30.0	20	20	°C		
			584	Heat Min Water Setpoint	In heating mode, Customer minimum Water Temperature	20.0 to 40.0	20	20	°C		
			585	Heat Max Water Setpoint	In heating mode, Customer maximum Water Temperature	30.0 to 60.0	38	38	°C		
			402	Heat Sleep Offset	Water offset for heating mode when Occupancy mode = Sleep	-10.0 to 0.0	0.0	-5	^C		
			403	Heat Away Offset	Water offset for heating mode when Occupancy mode = Away	-10.0 to 0.0	-5.0	-10	^C		
			412	Heat Curv Max Stp Offset	Heat Maximum Water Setpoint can be offsetted by this parameter, to adjsut at best the setpoint at customer needs	-5.0 to 5.0	0	5	^C		
			586	Cool Clim Curv Select	Cooling climatic curve select	-1 to 2	-1	0	-		
			587	Cool Minimum OAT	In cooling mode, Customer minimum OAT	0.0 to 30.0	20	22	°C		
			588	Cool Maximum OAT	In cooling mode, Customer maximum OAT	24.0 to 46.0	35	35	°C		
			589	Cool Min Water Setpoint	In cooling mode, Customer minimum Water Temperature	5.0 to 20.0	10	7	°C		
			590	Cool Max Water Setpoint	In cooling mode, Customer maximum Water Temperature	5.0 to 20.0	18	15	°C		
			408	Cool Sleep Offset	Water offset for cooling mode when Occupancy mode = Sleep	0.0 to 10.0	0	2	^C		
			409	Cool Away Offset	Water offset for cooling mode when Occupancy mode = Away	0.0 to 10.0	5	5	^C		
413	Cool Curve Min Stp Offset	Cool Minimum Water Setpoint can be offsetted by this parameter, to adjsut at best the setpoint at customer needs	-5.0 to 5.0	0	5	^C					

### 3 - INSTALLATION OF SYSTEM

#### 3.9 - Unit with remote user interface

In this configuration, the user interface is an accessory and must be installed indoors by the installer.

**IMPORTANT: For more information on:**

- how to use this user interface, please refer to WUI end user manual,
- the setpoint control, refer to §4.2.5 Setpoint,
- WUI installation document, refer to document provided with accessory.





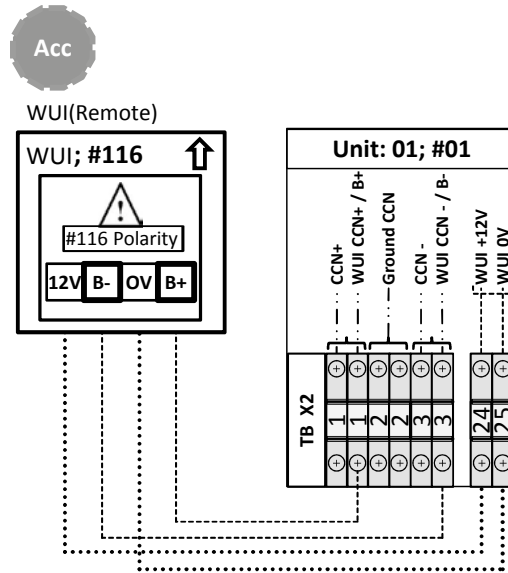





















##### 3.9.1 - Electrical connection

Figure 24: Electrical connection of remote interface



### 3 - INSTALLATION OF SYSTEM

#### 3.9.2 - Control configuration steps

N°	Steps	Table	Par.	Designation	Description	Range	Default	Ex.	Unit	Access	Check
1	Check on WUI screen that the unit is configured in Remote Interface	UI_CONF	521	User Interface Type	0 = No User Interface 1 = Remote control by contacts or SUI 2 = WUI remotely installed in the house 3 = WUI locally installed on the unit	0 to 3	0	2	-		
					Check on WUI screen that the unit is configured in Air setpoint 						
2	Control on air setpoint	AIR_STP	421	Heat Home Setpoint 	Air setpoint for heating mode when Occupancy mode = Home	12.0 to 34.0	19	20	°C		
			422	Heat Sleep Offset 	Air offset for heating mode when Occupancy mode = Sleep	-10.0 to 0.0	-2.0	-1	°C		
			423	Heat Away Offset 	Air offset for heating mode when Occupancy mode = Away	-10.0 to 0.0	-4.0	-3	°C		
			424	Cool Home Setpoint 	Air setpoint for cooling mode when Occupancy mode = Home	20.0 to 38.0	26	24	°C		
			425	Cool Sleep Offset 	Air offset for cooling mode when Occupancy mode = Sleep	0.0 to 10.0	2	2	°C		
			426	Cool Away Offset 	Air offset for cooling mode when Occupancy mode = Away	0.0 to 10.0	4	4	°C		
3a	First possibility: control on predefined climatic curve	CLIMCURV	581	Heat Clim Curv Select	0 = No Curve / Fixed Water Setpoint 1 to 12 = Heating Climatic Curve #number 13 = Custom Climatic Curve	-1 to 12	-1	2	-		
			412	Heat Curv Max Stp Offset	Heat Maximum Water Setpoint can be offseted by this parameter, to adjsut at best the setpoint at customer needs	-5.0 to 5.0	0	5	°C		
			586	Cool Clim Curv Select	0 = No Curve / Fixed Water Setpoint 1 to 2 = Cooling Climatic Curve #1number 3 = Custom Climatic Curve	-1 to 2	-1	1	-		
			413	Cool Curve Min Stp Offset	Cool Minimum Water Setpoint can be offseted by this parameter, to adjsut at best the setpoint at customer needs	-5.0 to 5.0	0	5	°C		
3b	Second possibility: control on fixed LWT setpoint	WAT_STP	581	Heat Clim Curv Select	Heating climatic curve select	-1 to 12	-1	-1	-		✓
			401	Heat Home Setpoint 	Water setpoint for heating mode when Occupancy mode = Home	20.0 to 60.0	45	50	°C		
			402	Heat Sleep Offset 	Water offset for heating mode when Occupancy mode = Sleep	-10.0 to 0.0	0.0	-5	°C		
			403	Heat Away Offset 	Water offset for heating mode when Occupancy mode = Away	-10.0 to 0.0	-5.0	-10	°C		
			586	Cool Clim Curv Select	Cooling climatic curve select	-1 to 2	0	-1	-		✓
			407	Cool Home Setpoint 	Water setpoint for cooling mode when Occupancy mode = Home	0.0 to 18.0	12	18	°C		
			408	Cool Sleep Offset 	Water offset for cooling mode when Occupancy mode = Sleep	0.0 to 10.0	0	2	°C		
			409	Cool Away Offset 	Water offset for cooling mode when Occupancy mode = Away	0.0 to 10.0	5	5	°C		
3c	Third possibility: control on customer climatic curve	CLIMCURV	581	Heat Clim Curv Select	Heating climatic curve select	-1 to 12	-1	0	-		
			582	Heat Minimum OAT	In heating mode, Customer minimum OAT	-30.0 to 10.0	-7.0	-20	°C		
			583	Heat Maximum OAT	In heating mode, Customer maximum OAT	10.0 to 30.0	20	20	°C		
			584	Heat Min Water Setpoint	In heating mode, Customer minimum Water Temperature	20.0 to 40.0	20	20	°C		
			585	Heat Max Water Setpoint	In heating mode, Customer maximum Water Temperature	30.0 to 60.0	38	38	°C		
			412	Heat Curv Max Stp Offset	Heat Maximum Water Setpoint can be offseted by this parameter, to adjsut at best the setpoint at customer needs	-5.0 to 5.0	0	5	°C		
			586	Cool Clim Curv Select	Cooling climatic curve select	-1 to 2	-1	0	-		
			587	Cool Minimum OAT	In cooling mode, Customer minimum OAT	0.0 to 30.0	20	22	°C		
			588	Cool Maximum OAT	In cooling mode, Customer maximum OAT	24.0 to 46.0	35	35	°C		
			589	Cool Min Water Setpoint	In cooling mode, Customer minimum Water Temperature	5.0 to 20.0	10	7	°C		
			590	Cool Max Water Setpoint	In cooling mode, Customer maximum Water Temperature	5.0 to 20.0	18	15	°C		
			413	Cool Curve Min Stp Offset	Cool Minimum Water Setpoint can be offseted by this parameter, to adjsut at best the setpoint at customer needs	-5.0 to 5.0	0	5	°C		

## 3 - INSTALLATION OF SYSTEM

### 3.10 - Additional OAT sensor

If the unit is unfavorably located, leading to incorrect reading of OAT, it is possible to install an additional outdoor air temperature sensor, located in an appropriate position. This sensor is available as an accessory (refer to §1.6.1 Options and accessories tables). For more details on its installation, refer to accessory document.

#### 3.10.1 - Electrical connection

Figure 25: Electrical connection of additional OAT sensor and IAT sensor

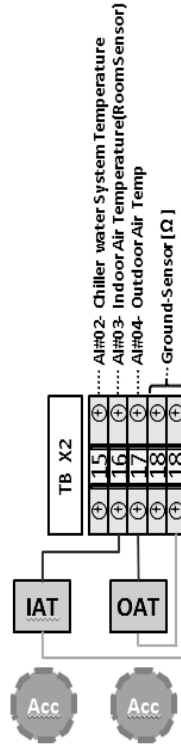

#### 3.10.2 - Control configuration steps

Steps	Table	Par.	Designation	Description	Range	Default	Ex.	Unit
Configure an additional Outdoor air temperature sensor	GEN_CONF	511	OAT sensor type	0 = No additional OAT sensor 1 = 10kOhm additional OAT sensor (connected on NHC Board) 2 = 5kOhm additional OAT sensor (connected on NHC Board) 3 = 3kOhm additional OAT sensor (connected on NHC Board)	0 to 3	0	3	-

### 3.11 - IAT sensor

If needed, it is possible to add an Indoor Air Temperature sensor, which measures the room temperature instead of the WUI air temperature sensor (when WUI remote) or when there is no user interface. When this sensor is installed and configured, IAT value is compared to air setpoint to determine the demand in heating or cooling.

#### 3.11.1 - Electrical connection

For details on electrical connection, refer to Figure 25 Electrical connection of additional OAT sensor and IAT sensor.

#### 3.11.2 - Control configuration steps

Steps	Table	Par.	Designation	Description	Range	Default	Ex.	Unit
Check that the unit is configured in Air setpoint	UI_CONF	521	User Interface Type	0 = No User Interface 1 = Remote control by contacts or SUI 2 = WUI remotely installed in the house 3 = WUI locally installed on the unit	0 to 3	0	2 (Even if localWUI )	-
				Check on WUI screen that the unit is configured in Air setpoint 				
Set a IAT sensor	GEN_CONF	510	IAT Sensor Type	0 = No IAT sensor 1 = 10 KOHms Thermistor 2 = 5 KOHms Thermistor 3 = 3 KOHms Thermistor	0 to 3	0	2	-

To configure the setpoint, refer to §3.9.2. Control configuration steps.

## 4 - OPERATION

### 4.1 - Unit range

#### a. - 30RBV 17-21

Evaporator Water Temperature	°C	Minimum	Maximum
Entering water temperature at start-up		6 <sup>(3)</sup>	30
Leaving water temperature during operation		5 <sup>(3)</sup>	18
Condenser Air Temperature	°C	Minimum	Maximum
Standard unit		-10 <sup>(2)</sup>	46

<sup>(1)</sup> 60°C for 30RQV 17 and 57°C for 30RQV 21

<sup>(2)</sup> For operation at outdoor ambient temperature below 0°C (cooling mode and heating mode), the water freeze protection should be available and according to the water installation, the water loop can be protected against frost by the installer, using an anti-freeze solution or trace heater.

<sup>(3)</sup> Minimum leaving water temperature of 7°C and minimum entering water temperature of 7.5°C for air temperature of -10°C to 0°C for 30RBV 17-21

#### Operating range 30RBV 17 -21 units

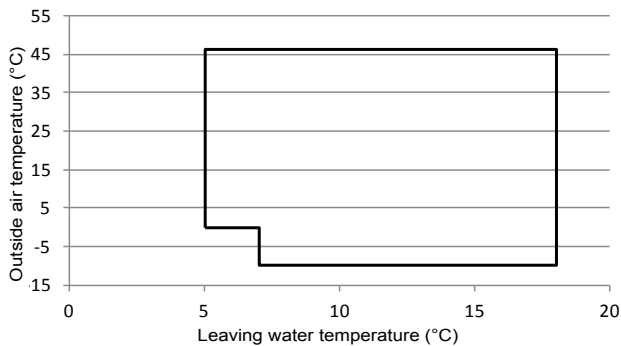

#### b. - 30RQV 17-21

Cooling Cycle			
Evaporator Water Temperature	°C	Minimum	Maximum
Entering water temperature at start-up		6	30
Leaving water temperature during operation		5	18
Condenser Air Temperature	°C	Minimum	Maximum
Standard unit		0	46
Heating Cycle			
Condenser Water Temperature	°C	Minimum	Maximum
Entering water temperature at start-up		10	45
Leaving water temperature during operation		20	60 / 57 <sup>(1)</sup>
Evaporator Air Temperature	°C	Minimum	Maximum
Standard unit		-20 <sup>(2)</sup>	30

<sup>(1)</sup> 60°C for 30RQV 17 and 57°C for 30RQV 21

<sup>(2)</sup> For operation at outdoor ambient temperature below 0°C (cooling mode and heating mode), the water freeze protection should be available and according to the water installation, the water loop can be protected against frost by the installer, using an anti-freeze solution or trace heater.

#### Operating range 30RQV 17-21 units, Cooling mode

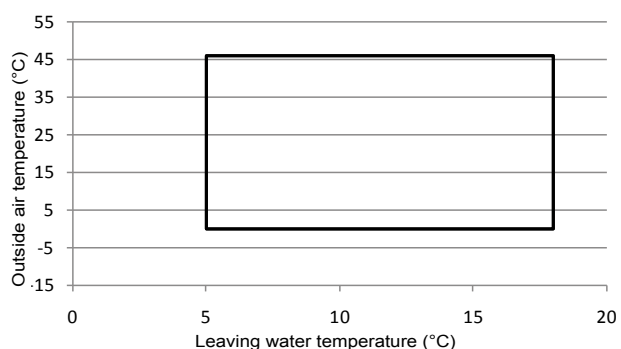

#### Operating range 30RQV 17-21 units, Heating mode

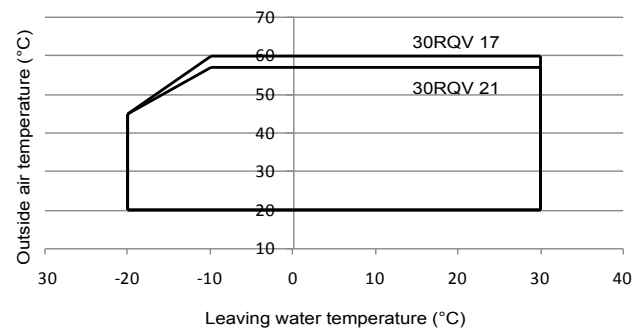

### 4.2 - Operating modes

#### 4.2.1 - Occupancy mode

Depending on unit configuration, the system can be controlled in two ways. The first possible method embraces the use of setpoints, where the outdoor air temperature has no effect on the temperature set by the control. The second control method is based on a climatic curve. In this case, the water temperature is adjusted in response to changes in the external temperature.

The unit may operate in HOME, SLEEP, or AWAY mode. The occupancy can be set manually by the user or automatically according to the schedule (refer to WUI end user manual).

Occupancy	WUI Display	Comfort Type
Home		Comfort
Sleep		Comfort
Away		Eco

**CAUTION:** In case of power cycle, the previous operating mode (cooling / heating / DHW) or occupancy mode (home / sleep / away) will be automatically restored.

#### 4.2.2 - Operating modes

The user can normally choose one of three available operating modes, i.e. cooling, heating or domestic hot water production only. Other modes such as booster cooling or booster heating, purge, and drying, can be selected only with service access level.

**The unit may run in the following modes:**

- **Off:** Unit is requested to stop.
- **Cool:** Unit is requested to run in Cooling mode.
- **Heat:** Unit is requested to run in Heating mode.
- **DHW Only:** Unit is requested to run in DHW mode Only.
- **Booster Cool:** Unit is requested to run in Cooling mode at maximum compressor frequency.
- **Booster Heat:** Unit is requested to run in Heating mode at maximum compressor frequency.
- **Purge:** Water pump is requested to run in order to purge the hydraulic circuit.
- **Drying:** Unit is requested to run in Heating mode and the heating water setpoint is increased in order to dry UFH.

## 4 - OPERATION

When Cooling mode is selected, the chiller or heat pump will operate in the Cooling mode in order to cool the water loop to the selected temperature.

When the heat pump is in Heating mode, the heat pump heats the water loop to the selected temperature. When the outdoor air temperature is very low, electric heaters or boiler heating can be used in order to satisfy the heating demand.

When DHW Only is requested, the unit is not allowed to operate in cooling or heating modes.

It is also possible for the unit to operate in DHW mode when heating mode or cooling mode is selected, according to schedule / temperature condition / maximum runtime.

When the system is in the Off mode, the compressor and the pump are stopped (except for home anti-freeze protection and water freeze protection, refer to § 4.2.6 Home anti-freeze protection and 4.2.7 Water freeze protection).



**Table 4: Different operating modes**

System Mode	WUI display	Icon
Off	-	[no icon]
Cool		[steady icon]
Heat		[steady icon]
DHW only		[steady icon]
Booster Cool *		[flashing fast]
Booster Heat *		[flashing fast]
Purge *		[flashing fast]
Drying *		[flashing slow]

\* Service access level only (with password 0120).

**For more information on user interface, please refer to the WUI end user manual.**

### b - Proprietary Protocol communication

The unit can be started or stopped and its operating mode can be selected from the network.

Steps	Table	Par.	Designation	Description	Range	Default	Ex.	Unit
Mode selection on WUI advanced menu	MOD_REQ	44	System Mode Request	0 = Off 1 = Cool 2 = Heat 4 = DHW 5 = Booster Cooling 6 = Booster Heating 8 = Purge (water pump is constantly running to purge the hydraulic circuit) 9 = Drying (slow water temp. ramp-up in Heating mode for UFH drying)	0 to 9	-	1	-

### c - JBus communication

The unit can be started or stopped and its System Mode can be selected from the JBus network. Refer to JBus registers in § 7. Parameter overview.

## 4 - OPERATION

### 4.2.4 - Switches

Some modes described below (summer mode / night mode...) could be activated or deactivated by switches. Moreover other remote contacts can be connected to the unit in order to add new features. If the unit is managed by remote contacts, it is necessary to change the value of parameter User Interface type in UI\_CONF table, with [P521] = 1.

**Table 5: Possible switches to install on system**

Switch	Definition
On/Off Switch (remote)	Used to start and stop the unit (if no user interface).
Mode Heat/Cool (remote)	Used to select (if no user interface): - Cooling Mode = contact opened - Heating Mode = contact closed
Normal/Eco (remote)	Used to select (if no user interface): - Home Mode = contact opened - Away Mode = contact closed
Safety Input Contact	This contact should be a 'normally closed' type. Parameter [P501] is used to configure the safety contact type: 1 = Full Safety Contact: unit is stopped when contact is opened 2 = Under Floor Heating Safety Contact: Heating Mode is not allowed when contact is opened 3 = Under Floor Cooling Safety Contact: Cooling Mode is not allowed when contact is opened
Power Limitation Contact (Night Mode)	Used to reduce the compressor maximum frequency to avoid noise
Off Peak Contact	This switch is to close when the rate electricity price is high (Electric Heat Stages are not allowed)
Loadshed Request Switch	This contact is requested by electricity company (i.e. in Germany) to control the green electricity (wind, solar) production and consumption more efficiently. When switch is closed then unit shall be stopped as soon as possible
Solar Input Contact	When switch is closed then the unit is not allowed to run in Heating or DHW Mode because hot water is produced from a solar source
DHW Request Switch from tank	When this input is closed, the Domestic Hot Water production is requested. A thermal switch mounted on the Domestic Hot Water tank shall be connected to this input
DHW Priority Contact (pulse input)	When the status of this input goes from closed to open (falling edge – pulse style input), the unit allowed to switch to Domestic Hot Water production for the programmed duration [P708] regardless of the Space Heating demand and the current DHW schedule
Anti-Legionella Cycle Request Button	When the status of this input goes from closed to open (falling edge), the Domestic Hot Water production is requested with the Anti-Legionella setpoint
Summer Switch	Used to select the Summer Mode (contact closed)
Energy Meter Input	This input is used to count the number of pulses received from an external energy meter (not supplied)
External Alarm Indication Input	When this input is opened, alarm is tripped. This alarm is for information only, it does not affect the unit operation.

### 4.2.5 - Setpoint

Depending on the unit configuration, the system control can be based on either water or air setpoint control.

To achieve better comfort, it is possible to adjust the room temperature setpoint (remoteuser interface) or water temperature setpoint (local user interface) according to your needs. Please note that the temperature setpoint can be adjusted only within a range defined for each occupancy mode.

**Table 6: Possible setpoint configurations**

Setpoint	Without WUI	Local WUI	Remote WUI
Without IAT	Water	Water	Air
IAT	Air	Air	Air

#### 1/ Predefined climatic curves

 **COOLING:** If the cooling climatic curve [P586] is configured to “1” or “2”, the water setpoint will be calculated according to the selected cooling climatic curve.

Two predefined cooling climatic curves are available:

Climatic Curve	Min. OAT	Max. OAT	Min. Water Temp	Max. Water Temp	Application
K1	20°C	40°C	5°C	10°C	FCU's
K2	20°C	40°C	10°C	18°C	UFC

The water setpoint calculation can be based on:

- 1/ Predefined Climatic Curves** depending on OAT: climatic curves already preconfigured in the control logic.
- 2/ Fixed Water Setpoint:** using a fixed value for each occupancy mode.
- 3/ Custom Climatic Curve** depending on OAT: define customized climatic curves in function of the application.
- 4/ Offset on climatic curves** (predefined and customer)

#### a - Installation without user interface or with local user interface

When the unit has no user interface or the unit is equipped with a local user interface, the control can only be implemented on the water temperature setpoint.

## 4 - OPERATION

### Cooling Climatic Curves

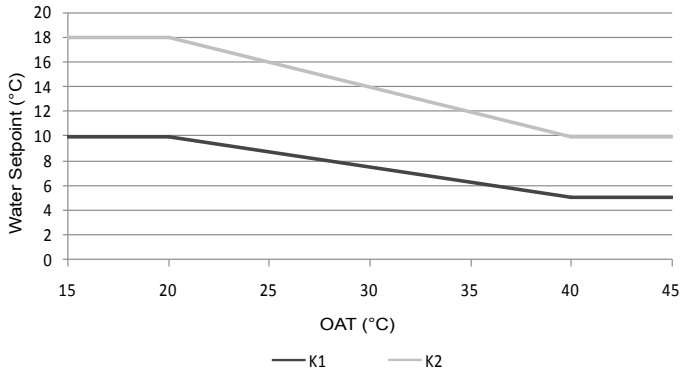

If OAT is invalid (not transmitted by the Inverter, out-of-range value, etc.), the Water Setpoint is equal to the current Min. Water Temp.

If OAT is above the current Maximum OAT threshold, the Water Setpoint is equal to the current Max. Water Temp.

✳ **HEATING:** If the heating climatic curve [P581] is configured to a parameter from “1” to “12”, the water setpoint will be calculated according to the selected heating climatic curve.

Twelve predefined heating climatic curves are available:

Climatic Curve	Min. OAT	Max. OAT	Min. Water Temp	Max. Water Temp	Application
K1	-7°C	20°C	20°C	38°C	UFH
K2	-5°C	20°C	20°C	33°C	UFH
K3	-9°C	20°C	20°C	45°C	FCU's
K4	-8°C	20°C	40°C	50°C	FCU's
K5	-5°C	20°C	40°C	55°C	Radiators
K6	0°C	20°C	40°C	60°C	Radiators
K7	-20°C	20°C	22°C	42°C	FCU's
K8	-20°C	20°C	23°C	55°C	Radiators
K9	-12.7°C	20°C	24°C	60°C	Radiators
K10	-5.9°C	20°C	25°C	60°C	Radiators
K11	-1.5°C	20°C	26°C	60°C	Radiators
K12	3.5°C	20°C	27°C	60°C	Radiators

**Example:**

### Heating Climatic Curves (K7 to K8)

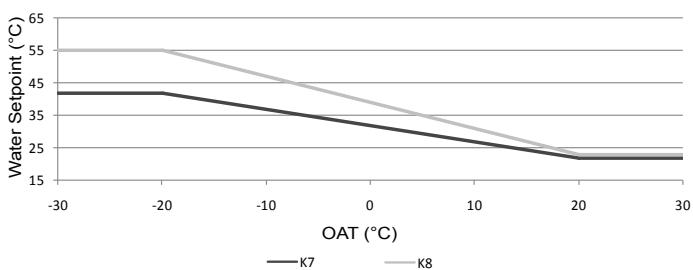

- If OAT is invalid (not transmitted by the Inverter, out-of-range value, etc.), the Water Setpoint is equal to the current Max. Water Temp.

- If OAT is above the current Maximum OAT threshold, the Water Setpoint is equal to the current Min. Water Temp.

The climatic curve corresponds to the water setpoint in Home mode. To define the other occupancy modes, it is necessary to configure Cool Sleep Offset [P408] and Cool Away Offset [P409]:

### Cooling Climatic Curve in function of occupancy mode

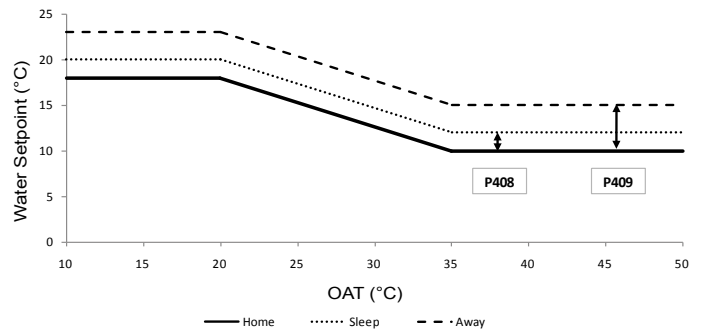

The climatic curve corresponds to the water setpoint in Home mode. To define the other occupancy modes, it is necessary to configure Heating Sleep Offset [P402] and Heating Away Offset [P403]:

### Heating Climatic Curve in function of occupancy mode

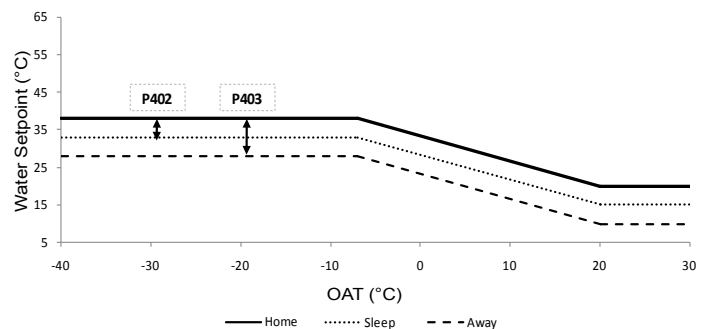



## 4 - OPERATION

### 2/ Fixed water setpoint

If the cooling climatic curve [P586] or the heating climatic curve [P581] is configured to “-1”, the water control point will be determined according to the Occupancy mode.

The water setpoint can be configured in two ways:

- By direct access to the WUI (refer to WUI end-user manual)
- By accessing the parameter menu via WUI or JBus or Proprietary Protocol (refer to § 7. Parameter Overview)

#### COOLING

WUI Occupancy	Water setpoint on WUI direct access	Range	Water setpoint on parameter menu	Range
	Cool Home Setpoint	5 to 18°C	Cool Home Setpoint [P407]	5 to 18°C
	Cool Sleep Setpoint	5 to 18°C	Cool Home Setpoint [P407] + Cool Sleep Offset [P408]	0 to 10°C
	Cool Away Setpoint	5 to 18°C	Cool Home Setpoint [P407] + Cool Away Offset [P409]	0 to 10°C

#### HEATING

WUI Occupancy	Water setpoint on WUI direct access	Range	Water setpoint on parameter menu	Range
	Heat Home Setpoint	20 to 60°C	Heat Home Setpoint [P401]	20 to 60
	Heat Sleep Setpoint	20 to 60°C	Heat Home Setpoint [P401] + Heat Sleep Offset [P402]	-10 to 0°C
	Heat Away Setpoint	20 to 60°C	Heat Home Setpoint [P401] + Heat Away Offset [P403]	-10 to 0°C

#### DHW only (setpoints defined below change also the setpoints for DHW mode)

WUI Occupancy	Water setpoint on WUI direct access	Range	Water setpoint on parameter menu	Range
	DHW Setpoint	30 to 60°C	DHW Setpoint [P406]	30 to 60°C
	DHW Anti-Legionella Stp	50 to 60°C	DHW Anti-Legionella Stp [P405]	50 to 60°C

### 3/ Custom climatic curve

**COOLING:** If the cooling climatic curve [P586] is configured to “0”, the water setpoint will be calculated according to the custom cooling climatic curve.

This custom cooling climatic curve can be defined using the following parameters:

Parameter	Description	Default	Min.	Max.
P587	Custom Minimum OAT	20°C	0°C	30°C
P588	Custom Maximum OAT	35°C	24°C	46°C
P589	Custom Minimum Water Temp	10°C	5°C	18°C
P590	Custom Maximum Water Temp	18°C	5°C	18°C

**Example:**

Custom Cooling Climatic Curve

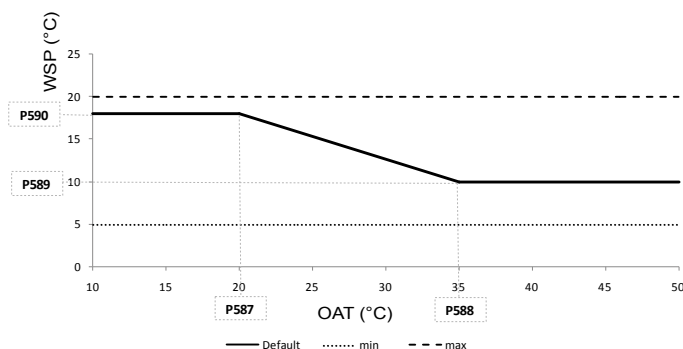

- If OAT is invalid, the Water Setpoint is equal to the Custom Minimum Water Temp [P589].

- If OAT is above the current Maximum OAT threshold, the Water Setpoint is equal to the Custom Maximum Water Temp [P590].

- If Minimum OAT is greater or equal to Maximum OAT threshold, the Water Setpoint is equal to the Custom Maximum Water Temp [P590].

**HEATING:** If the heating climatic curve [P581] is configured to “0”, the water setpoint will be calculated according to the custom heating climatic curve.

This custom heating climatic curve can be defined using the following parameters:

Parameter	Description	Default	Min.	Max.
P582	Custom Minimum OAT	-7°C	-30°C	10°C
P583	Custom Maximum OAT	20°C	10°C	30°C
P584	Custom Minimum Water Temp	20°C	20°C	40°C
P585	Custom Maximum Water Temp	38°C	30°C	60°C

**Example:**

Custom Cooling Climatic Curve

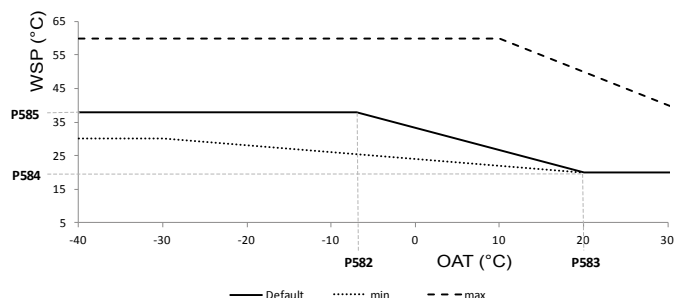

## 4 - OPERATION

- If OAT is invalid, the Water Setpoint is equal to the Custom Max. Water Temp [P585].
- If OAT is above the current Maximum OAT threshold, the Water Setpoint is equal to the Custom Min. Water Temp [P584].
- If Min. OAT is greater or equal to Max. OAT threshold, the Water Setpoint is equal to the Custom Max. Water Temp [P584].

### 4/ Offset on climatic curves (predefined and customer)

Two other parameters are also configurable to adjust water setpoint to suit customer needs:

- for cooling curve, Cool Minimum Water Setpoint [P589] can be offsetted by an offset on foot of the curve (Cool Curve Min Stp Offset [P413])
- and for heating curve, Heat Maximum Water Setpoint [P585] can be offsetted by an offset on head of the curve (Heat Curv Max Stp Offset [P412])

### Custom Cooling Climate Curve: Offset on foot of the curve

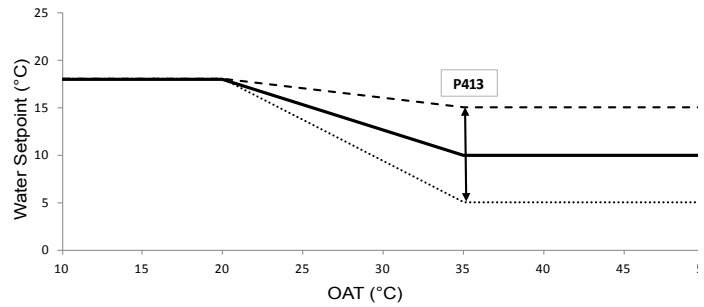

### Heating Climate Curve: Offset on head of the curve

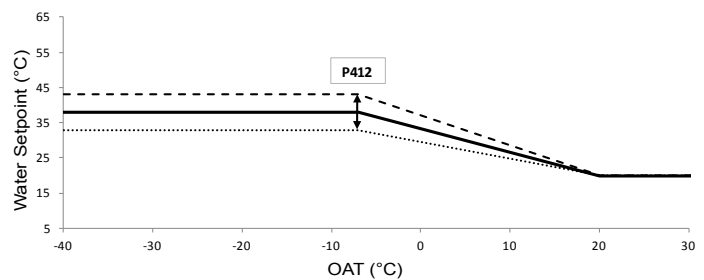

### b - Installation with remote user interface

When the unit is equipped with a remote user interface or IAT sensor, the control can be based on the air setpoint.

Depending on the occupancy and heating/cooling/DHW mode, the air setpoint is as given below.

The air setpoint can be configured in two ways:

- By direct access to the WUI (refer to WUI end-user manual)
- By access to the parameter menu via the WUI or JBus or Proprietary Protocol (refer to § 7. Parameter Overview)

### ⚙️ COOLING

WUI Occupancy	Air setpoint on WUI direct access	Range	Air setpoint on parameter menu	Range
	Cool Home Setpoint	20 to 38°C	Cool Home Setpoint [P424]	20 to 38°C
	Cool Sleep Setpoint	20 to 38°C	Cool Home Setpoint [P424] + Cool Sleep Offset [P425]	0 to 10°C
	Cool Away Setpoint	20 to 38°C	Cool Home Setpoint [P424] + Cool Away Offset [P426]	0 to 10°C

### ☀️ HEATING

WUI Occupancy	Air setpoint on WUI direct access	Range	Air setpoint on parameter menu	Range
	Heat Home Setpoint	12 to 34°C	Heat Home Setpoint [P421]	12 to 34°C
	Heat Sleep Setpoint	12 to 34°C	Heat Home Setpoint [P421] + Heat Sleep Offset [P422]	-10 to 0°C
	Heat Away Setpoint	12 to 34°C	Heat Home Setpoint [P421] + Heat Away Offset [P423]	-10 to 0°C

Once air setpoints are defined, water setpoints must be configured (refer to §3.9. Unit with remote interface).

### 4.2.6 - Home Anti-freeze protection

This protection is used on 30RQV, only with remote user interface or IAT sensor. It is used to maintain the minimum room temperature which is by default set to 6°C. When the room temperature goes below the Home Anti-freeze setpoint [P427], the unit will run in Heating mode until the room temperature is increased: [P427] + 2°C.

Steps	Table	Par.	Designation	Description	Range	Default	Ex.	Unit
Set the minimum room temperature	AIR_STP	427	Home Anti-freeze setpoint	This is the minimum room temperature that is allowed. If room temperature drops below this setpoint, the unit will start to operate in Heating mode.	6.0 to 12.0	6	10	°C

**Never switch off the unit, otherwise home anti-freeze protection cannot be guaranteed. For this reason the main unit and / or customer circuit disconnect switch must always be left closed.**

## 4 - OPERATION

### 4.2.7 - Water freeze protection

When the OAT is low (and pump is stopped), the risk to freeze the water exchanger and the water pipes is high. The pump shall be turned on regularly or continuously to make water circulate and decrease the risk. Likewise the BPHE and piping electric heaters present on the hydraulic kit (refer to Figures 7 and 8) are activated in some cases.

The pump is controlled as follows:

- If OAT goes below  $\text{AntiFreezeDeltaSetpoint}^* [\text{P517}] + 6^\circ\text{C}$ , the pump runs for 1 minute every 15 minutes at maximum speed.
- If OAT goes below  $\text{AntiFreezeDeltaSetpoint}^* [\text{P517}] + 6^\circ\text{C}$  and EWT or LWT goes below  $\text{AntiFreezeDeltaSetpoint}^* [\text{P517}] + 3^\circ\text{C}$ , the pump runs continuously at maximum speed.
- A 1K hysteresis is applied to exit these two overrides.

The electric heaters are controlled as follows:

- The electric heaters are energized during defrost and for 1 minute after defrost end.
- The electric heaters are energized if OAT is below the  $\text{AntiFreezeDeltaSetpoint}^* [\text{P517}] + 6.0^\circ\text{C}$  and if either EWT or LWT are lower than  $\text{AntiFreezeDeltaSetpoint}^* [\text{P517}] + 4.0^\circ\text{C}$ .
- The electric heaters are de-energized if OAT is above the  $\text{AntiFreezeDeltaSetpoint}^* [\text{P517}] + 7.0^\circ\text{C}$  or if both EWT (if configured) and LWT are higher than  $\text{AntiFreezeDeltaSetpoint}^* [\text{P517}] + 4.5^\circ\text{C}$ .
- The electric heaters are energized if either alarm #50 or alarm #51 is active and can still automatically be reset

**\* Modifying the pre-configured value is at the user's responsibility.**

Steps	Table	Par.	Designation	Description	Range	Default	Ex.	Unit
Define the criteria to activate the water freeze protection	GEN_CONF	517	Anti-Freeze Delta Setpoint	Outdoor air temperature criteria for activation of the anti freeze protection	0.0 to 6.0	0	3	°C

**Never switch off the unit, otherwise freeze protection cannot be guaranteed. For this reason the main unit and/or customer circuit disconnect switch must always be left closed.**

If a shut-off valve is installed, a bypass must be included as shown below.

**Figure 26: Winter position for unit with hydraulic module**

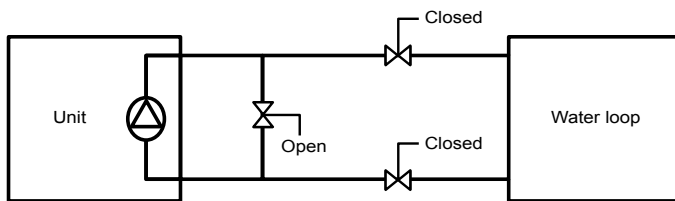

**Figure 27: Winter position for unit without hydraulic module**

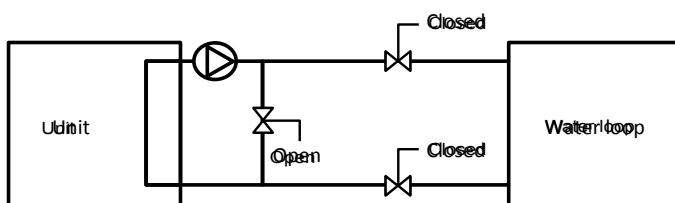

**IMPORTANT: Depending on the atmospheric conditions in your area you must do the following when switching the unit off in winter:**

- Add ethylene glycol or propylene glycol with an adequate concentration to protect the installation up to a temperature of 10 K below the lowest temperature likely to occur at the installation site.
- If the unit is not used for an extended period, it should be drained, and ethylene glycol or propylene glycol should be charged in the heat exchanger as a safety precaution, using the water inlet purge valve connection.
- At the start of the next season, refill the unit with water and add an inhibitor.
- For the installation of auxiliary equipment, the installer must comply with basic regulations, especially for minimum and maximum flow rates, which must be between the values listed in the operating limit table (application data).

- To prevent corrosion by differential aeration, the complete drained heat transfer circuit must be charged with nitrogen for a period of one month. If the heat transfer fluid does not comply with the manufacturer regulations, the nitrogen charge must be added immediately.
- If frost protection is dependent on electric trace heaters, never switch off their power.
- If trace heating is not used, or during a prolonged power failure, the unit water system must be drained to protect the unit.
- The heat exchanger temperature sensor are part of frost protection: If piping trace heaters are used, ensure the external heaters do not affect the measurement of these sensors.

**CAUTION:**

Please note that “water freeze protection” and “home anti-freeze protection” are two different modes. Water freeze protection is used in order to reduce the risk to freeze the water exchanger and the water pipes, whereas the home anti-freeze protection is used to maintain the minimum room temperature.

### 4.2.8 - Domestic hot water mode

For heat pumps with a domestic water tank (only 30RQV), the DHW mode is used to produce hot water for domestic purposes. The system control manages the operation of the hot domestic water tank, as well as the diverting valve.

If the unit is fitted with a variable speed hydraulic kit, then in DHW mode, the pump must be controlled by the adjustable constant speed logic (no  $\Delta T$  logic).

And an additional water pump can be installed on secondary water loop (refer to §Installation with DHW production and boiler for details).

## 4 - OPERATION

### a - DHW diverting valve

The units can drive a diverting valve to manage a domestic hot water storage tank application. In case of a domestic hot water request, the operating logic controls a diverting valve which directs the hot water to the storage tank.

<b>Characteristics</b>	Diverting valve with spring return and two wires control Recommendation: - Kvs = 16 - Max. Temperature = 150°C - CHAR:L
<b>Electrical connection</b>	Refer to § 3.5 Installation with DHW production
<b>Configuration</b>	Refer to § 3.5 Installation with DHW production

### b - DHW temperature sensor or thermostat

According the configuration, it is possible to control the DHW option with either a temperature sensor or thermostat

	Temperature sensor	Thermostat
<b>Characteristics</b>	Accessory Resistance = 10 KOHms Cable length = 6 m	When the thermostat is closed, the domestic hot water mode is requested
<b>Electrical connection</b>	Refer to § 3.5 Installation with DHW production	
<b>Configuration</b>	Refer to § 3.5 Installation with DHW production	

The DHW production is possible when:

- DHW only mode is selected and there is DHW production demand (temperature conditions)
- DHW schedule is activated and there is DHW production demand (temperature conditions) and operating time in this mode is below DHW Maximal Runtime [P707].

### c - DHW electric heater

When the unit is requested to run in DHW mode, the DHW electric heater (if configured) can be used in order to provide domestic hot water. The discrete output can control a contactor (not supplied with unit).

<b>Characteristics</b>	Contacteur Coil: 230 VAC 50Hz
<b>Electrical connection</b>	Refer to § 3.5 Installation with DHW production
<b>Configuration</b>	Refer to § 3.5 Installation with DHW production

Electric heater is started when tank temperature is below DHW setpoint and one of the following conditions is true:

- OAT is below Booster OAT Threshold [P604]
- OAT is above Maximum OAT for Heating [P515]
- Anti-legionella mode is active
- Defrost is active
- In case of unit of failure

#### **IMPORTANT:**

**Electric heating is disabled when Off Peak or Load Shedding is active or in the case of DHW thermistor sensor failure (refer to § 4.2.4 Switch).**

### d - Domestic water tank

The water inside the domestic water tank must be constantly controlled in order to minimize the risk of any contamination, including legionella bacteria. Bearing this in mind, it is important to inform the user about the significance of water temperature control.

### **Water tank protection system**

The system is scheduled to heat up water in the domestic hot water tank in order to eliminate the possibility of legionella growth or kill any existing bacteria.

Legionella will not survive if the temperature is above 50°C. The risk of contamination is practically non-existent when the water temperature is set to 60°C.

### **Water tank protection settings**

To protect the domestic water tank against legionella bacteria, the following parameters must be set:

- Anti-Legionella Start Day of Week [P714]
- Anti-Legionella Start Time [P715]
- Anti-Legionella Water Setpoint [P405] (anti-legionella protection is stopped when the water temperature reaches the pre-set temperature)

### e - DHW limitation mode

DHW limitation mode [P543] reduces noise levels, by reducing the compressor frequency when DHW mode is active. For configuration, refer to § 3.5.

## 4.2.9 - Master/Slave up to 4 units

### a - Installation

Master/slave installation permits connection of up to four units in parallel: one master unit can control from one to three slave units.

This kind of installation must comprise the same unit type (cooling only or reversible) and same unit size (17kW or 21kW), equipped with hydraulic kit (variable or fixed speed kit). If the unit is fitted with a variable speed hydraulic kit, the pump must be controlled by the adjustable constant speed logic (no ΔT logic). The master / slave operation is incompatible with Domestic Hot Water production.

Only the Master unit can be fitted with user interface (local or remote) and Bacnet or Lon gateway options. If the Slave units have been ordered with these features, then it is necessary to disconnect them.

Additional common leaving water temperature sensor must be installed on site, on the common piping.

<b>Characteristics</b>	Accessory Resistance = 5 KOHms Cable length = 15 m
<b>Electrical connection</b>	Refer to § 3.7 Master/Slave installation
<b>Configuration</b>	Refer to § 3.7 Master/Slave installation

The RS485 communication cable (not supplied) must be connected on each unit.

### b - Control

All units installed in the same master/slave group share the same operating mode as well as the same setpoint.

The Master unit is connected to a user interface which can be installed locally or remotely. The "Master" user interface is a decision point for all other units in the same master/slave group, which means that the operating mode (cooling / heating) and the water setpoint defined by the master will be transmitted to other "slave" units.

When there are at least two units configured in the master/slave assembly, it is possible to define how compressors are started. Three compressor control methods are available.

## 4 - OPERATION

### Compressors can be started:

**Based on address configuration:** The Master unit is started first. Then, slave units will be started sequentially (beginning with slave 1 and ending with, for example, slave 3). When stopping, the last slave is stopped first – the Master is the last unit stopped.

**According to wear factor:** Units are started sequentially based on the wear factor. As system demand increases, the unit with the lowest wear factor is started first, when system demand decreases capacity, the unit with, the highest wear factor is stopped first.

**Simultaneously:** All units are started and stopped at the same time. Compressor frequency is increased or decreased simultaneously on all units.

For more details on Master /Slave icon display on WUI, refer to WUI end-user manual.

### CAUTION:

**In the case of master/slave communication failure, the Master will either run in the standalone mode or it will continue to operate with other Slave units that are still communicating. The affected Slave unit will stop all of its operations.**

### 4.2.10 - Pump configuration

There are several possible configurations of the hydraulic circuit:

- Unit with hydraulic module (internal main pump included),
- Unit without hydraulic module. An external pump is necessary,
- If a secondary hydraulic loop is used, this will have its own additional pump.

**Table 7: Different configurations of pump**

Different configurations with pump	Internal main pump (option)			External main pump (not supplied)	Additional pump (not supplied)
	Fixed speed pump	Variable speed pump		Fixed speed pump	Fixed speed pump
Adjustable speed		ΔT			
Internal main pump				x	✓
External main pump				x	✓
Master / Slave installation	✓	✓	x	x	✓ (Connected on master unit)

For external main pump and additional pump, the discrete output can control a contactor (not supplied with unit).

<b>Characteristics</b>	Contacteur Coil: 230 VAC 50Hz
<b>Electrical connection</b>	Refer to § 3.6 Installation with DHW production and boiler
<b>Configuration</b>	Refer to § 3.6 Installation with DHW production and boiler

### CAUTION:

**The installer is responsible for ensuring the protection of any additional pump against the low water flow rate (no flow switch can be managed by unit control).**

The management of different states of main pump (ON / OFF) is different according to the kind of installation (options, accessories, applications). In the compatibility table below, the different control logics for main pump are presented in function of installation:

**Table 8: Different control logic for main pump**

Main Pump Logic [P565]	No WUI	Local WUI	Remote WUI	OFF Mode	Cooling / Heating Mode		Boiler	
					Satisfied Demand	Demand	On	Off
Always On	✓	✓	✓	Off	On	On	Off	N.A.
Water Sampling	✓	✓	N.A.	Off	Off (On for sampling)	On	Off	N.A.
According to Space Temp	N.A.	N.A.	✓	Off	According to IAT vs Air Setpoint	On	Off	N.A.

The management of different states of additional pump (ON / OFF) is different according to the kind of installation (options, accessories, applications). In the compatibility table below, the different control logics for additional pump are presented in function of installation:

**Table 9: Different control logic for additional pump**

Additional Pump Logic [P573]	No WUI	Local WUI	Remote WUI	OFF Mode	Cooling / Heating Mode		Boiler		DHW	
					Satisfied Demand	Demand	On	Off	Active	Inactive
No additional pump	✓	✓	✓	Off	Off	Off	Off	N.A.	N.A.	N.A.
Always On	✓	✓	✓	Off	On	On	On	N.A.	N.A.	N.A.
According to Space Temp	N.A.	N.A.	✓	Off	According to IAT vs Air Setpoint	On	On	N.A.	N.A.	N.A.
Always On, but Off when DHW activated	✓	✓	✓	Off	On	On	On	N.A.	Off	N.A.
According to Space Temp, but Off when DHW activated	N.A.	N.A.	✓	Off	According to IAT vs Air Setpoint	On	On	N.A.	Off	N.A.

## 4 - OPERATION

### 4.2.11 - Electric Heaters

**NOTE:**

**The installer is responsible for ensuring that the installation complies with the applicable legislation in terms of electrical and thermal safety.**

It is possible to include electric heaters in the hydraulic circuit to ensure heating in case of low OAT or heat pump failure.

When OAT is below Booster OAT Threshold [P604], then the booster electric heaters can be activated. The booster electric heaters can operate at the same time as the heat pump.

When OAT is below Min OAT for heating [P514], the heat pumps is stopped, and the electric heaters can be activated.

**Figure 28: Operation of booster and backup**

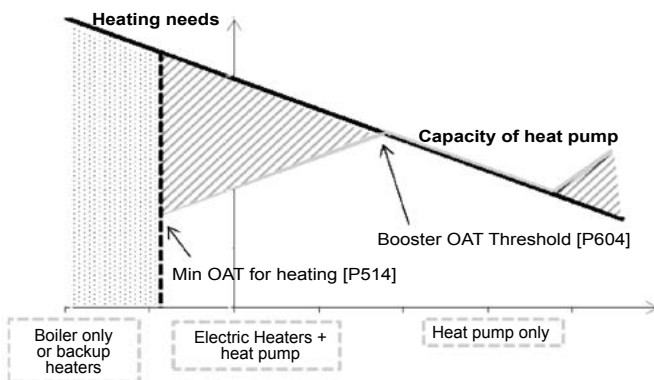

Depending on the configuration, it is possible to control up to three electric heaters or three electric heat stages (refer to § 3.1 General customer electrical connection on terminal block):

- One electric heat stage with one customized discrete output: EH1.
- Two electric heat stages with two customized discrete outputs: EH1 and EH2.
- Three electric heat stages with two customized discrete outputs: EH1 and EH2.
- Three electric heat stages with three customized discrete outputs: EH1 and EH2 and EH3. This configuration cannot be activated if DHW heater is present.

### 4.2.15 - Night mode capacity control

The night period is defined by the start hour and the end hour which can be set by the user. The night mode allows users to configure the unit to operate with specific parameters within a given period of time, e.g. night period. Particularly this mode permits the reduction of compressor frequency (and noise level) during defined period.

Steps	Table	Par.	Designation	Description	Range	Default	Ex.	Unit
Set the night mode	CMP_CONF	541	Power Limitation value	The compressor frequency is limited to this percentage of the maximum allowed frequency.	50 to 100	75	50	%
		518	Night Mode Start Time	Hour of starting up of night mode	00:00 to 23:59	0:00	23:00	hh:mm
	GEN_CONF	519	Night Mode Stop Time	Hour of stop of night mode	00:00 to 23:59	0:00	7:00	hh:mm

Each discrete output can control a contactor (not supplied with unit).

<b>Characteristics</b>	Contactor Coil: 230 VAC 50Hz
<b>Electrical connection</b>	Refer to § 3.4 Installation with booster electric heaters
<b>Configuration</b>	Refer to § 3.4 Installation with booster electric heaters

### 4.2.12 - Boiler

To satisfy the heating demand during periods very low ambient temperature, it is possible to install a boiler. The boiler is considered as a backup: when it is activated, the heat pump cannot operate. Boiler is activated when OAT is below Minimum OAT for Heating [P514] or in case of heat pump failure.

<b>Characteristics</b>	Contactor Coil: 230 VAC 50Hz
<b>Electrical connection</b>	Refer to § 3.6 Installation with DHW and boiler
<b>Configuration</b>	Refer to § 3.6 Installation with DHW and boiler

### 4.2.13 - Coil heating control for compressor

**CAUTION: When the unit doesn't operate, the compressor can be energized. The coil heating control has the function of heating the compressor by applying a current to the compressor when not operating instead of using a case heater. This control is for the purpose of preventing stagnation of the refrigerant inside the compressor.**

### 4.2.14 - Defrost cycle

When the outdoor air temperature is low and the ambient humidity is high, the probability of frost forming on the surface of the outdoor coil increases. The frost covering the outdoor coil may reduce the air flow across the coil and impair the performance of the unit. To remove the frost from the coil, the control initiates the defrost cycle when necessary.

During the defrost cycle, the refrigerant circuit is forced into the cooling mode. To prevent the water loop from cooling down, BPHE and piping electric heaters may be started.

**CAUTION:**

**Please note that "defrost" and "home anti-freeze protection" are two different modes. Defrost is used in order to remove the frost that is covering the outside coil, whereas the home anti-freeze protection is used to maintain the minimum room temperature.**

## 4 - OPERATION

### 4.2.16 - Drying mode

The Drying mode enables a gradual water temperature ramp-up in Heat mode for UFH drying. This operating mode can only be selected from the service access level, it is automatically stopped at the end of the configured period.





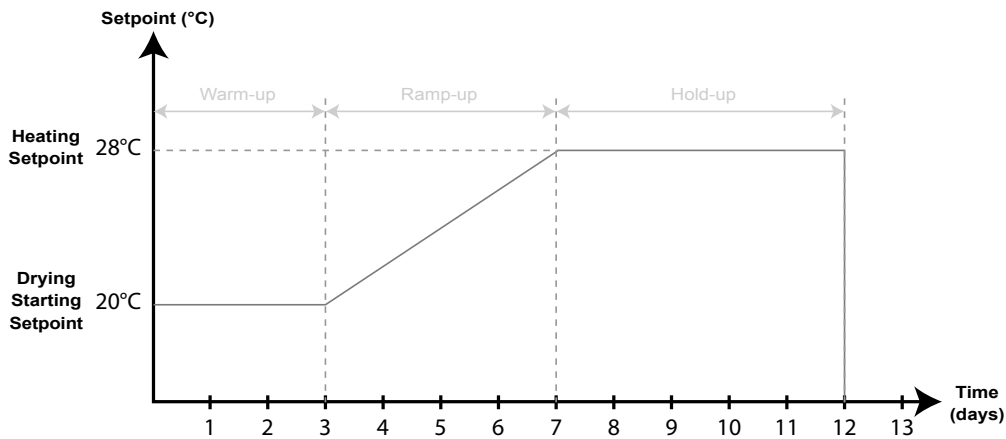

Example of application in drying mode:

- Drying Starting Setpoint[P595] is set to 20°C
- Drying Warm-up days [P596] is set to 3 days
- Drying Ramp-up days [P597] is set to 4 days
- Drying Hold-up days [P598] is set to 5 days
- and Heating Home Water Setpoint [P401] is set to 28°C

**Figure 29: Activation and configuration for drying mode**

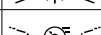
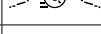

The Drying Mode will be deactivated after 12 days and the unit will switch to Off Mode.

Steps	Table	Par.	Designation	Description	Range	Default	Ex.	Unit	
Configure the number of days in drying mode	DRYING	596	Drying Warm-up days	Number of Warm-up days	0 to 99	3	3	day	
		597	Drying Ramp-up days	Number of Ramp-up days	0 to 99	4	4	day	
		598	Drying Hold-up days	Number of Hold-up days	0 to 99	4	5	day	
Configure the water temperature for drying mode	DRYING	595	Drying Starting Setpoint	Water setpoint to warm-up days	20.0 to 60.0	20	20	°C	
	WAT_STP	401	Heat Home Setpoint 	Water setpoint for ramp-up and hold up days	20.0 to 60.0	45	28	°C	
Activate the drying mode	MOD_REQ	44	System Mode Request	0 = Off		0 to 9	-	9	-
				1 = Cool					
				2 = Heat					
				4 = DHW					
				5 = Booster Cooling					
				6 = Booster Heating					
				8 = Purge (water pump is constantly running to purge the hydraulic circuit)					
				9 = Drying (slow water temp. ramp-up in Heating mode for UFH drying)					

### 4.2.17 - Summer mode

30RQV units may operate in Summer mode which is active under the following conditions:

- when the Summer Switch is closed
- or when conditions on OAT [P716] and time [P717] and [P718] are validated (refer to §3.5.3 Control configuration step).

When the Summer mode is active, then the unit may operate only as specified in the table below.

Cooling Mode	Heating Mode	DHW Mode
✓	✗	✓

# 4 - OPERATION

## 4.3 - Major system components

### 4.3.1 - General – Refrigerant part

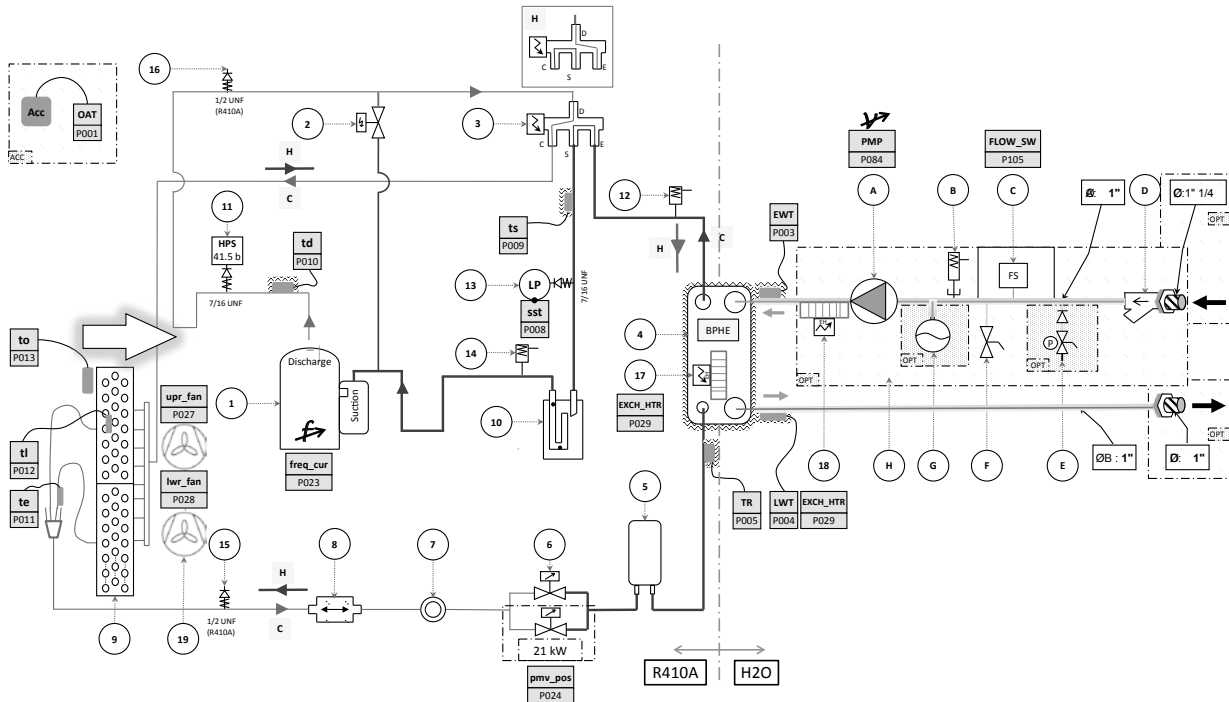

#### Water side legend

##### Label Description

- A Water Pump -Main water pump -primary loop (in Hydraulic module option)
- B Water High Pressure Safety Relief Valve (300 kPa) (in Hydraulic module option)
- C Flow Switch (standard)
- D Water Filter (standard in Hydraulic module option)  
--> To be supplied on field with a unit without Hydraulic module option (mandatory).
- E Water refill module (Option)
- F Drain valves (in hydraulic module option)
- G Expansion vessel (in option within Hydraulic Module option)
- H Hydraulic module (option)  
Hydraulic module equipped with Fixed or variable speed single pump without expansion vessel, Water refill module.

#### Unit refrigeration circuit legend

##### Label Description

- 1 Variable speed rotary compressor
- 2 2 way solenoid valve -CP Warm-up at start
- 3 Reverse 4 way valve (energized when in Heating mode)
- 4 Water exchanger - BPHE
- 5 Receiver
- 6 Expansion valve - pulse modulating valve (2x EXV for size 21)
- 7 Sight Glass
- 8 Filter Dryer
- 9 Air cooled Exchanger
- 10 Accumulator or anti-slugging bottle
- 11 High Pressure Switch (4 150 kPa ~ 41.5 b)
- 12 Pressure safety release valve @ suction on BPHE
- 13 Low Pressure transducer (mounted on Schrader valve)
- 14 Pressure safety release valve @ suction
- 15 Service Pressure AutomaticPort (Schrader) on LP side
- 16 Service Pressure AutomaticPort (Schrader) on HP side
- 17 Electrical Heater on BPHE: water anti-freeze protection
- 18 Electrical Heater on BPHE Inlet pipe (only with Hydraulic module option), water anti-freeze protection
- 19 Upper & Lower fans

**OAT** Software point

**P001** Value read under «Parameter number»; ie: OAT value read@ parameter 001 'P001'



## 4 - OPERATION

### 4.3.2 - Compressors

30RBV/RQV units use hermetic rotary compressor. It is driven by a variable frequency drive (VFD). The rotary compressor incorporates an oil coil heating inside the shell.

The compressor sub-assembly is complete with:

- Anti-vibration mountings between the unit and the compressor chassis.
- A high-pressure switch or compressor case thermostat control at the discharge of compressor.

The compressors installed in these units have a specific oil charge.

**NOTE: Do not use refrigerants and lubricant besides those specified. Do not compress air (there must be no air intake due to leakage in the refrigeration cycles).**

### 4.3.3 - Air evaporator/condenser

The 30RBV/RQV coils are heat exchangers with internally grooved copper tubes with aluminium fins.

### 4.3.4 - Fans

The fans are driven by permanent magnet synchronous motor. The motors are managed via a variable frequency drive (VFD).

According to the Regulation No. 327/2011 implementing Directive 2009/125/EC with regard to ecodesign requirements for fans driven by motors with an electric input power between 125 W and 500 kW.

Product		30RBV/RQV
Overall efficiency	%	29,1
Measurement category		A
Efficiency category		Static
Target efficiency level ERP2015		N(2015) 40
Efficiency level at the optimum efficiency point		40,6
Variable speed drive		YES
Year of manufacture		See label on the unit
Fan manufacturer		Complast Industrie SRL
Motor manufacturer		Nidec
Fan PN		C025223H01
Motor PN		B036870H01
Nominal power of the motor	kW	0,15
Flow rate	m <sup>3</sup> /s	0,84
Pressure at optimum energy efficiency	Pa	51
Nominal speed	rpm	847
Specific ratio		1,002
Relevant information to facilitate the disassembly, recycling or removal of the product at the end of the life		See Maintenance Manual
Relevant information to minimise the impact on the environment		See Maintenance Manual

According to the Regulation No. 640/2009 and amendment 4/2014 implementing Directive 2009/125/EC with regard to ecodesign requirements for electric motors.

Motor type	Permanent magnet synchronous motor
Motor included in the application domain of the regulation 640/2009 & amendment 4/2014	NO

### 4.3.5 - Pulse Motor Expansion Valve (PMV)

Each PMV is equipped with a stepper motor (0-500 pulses). The 17 kW units have one PMV in its refrigerant circuit, while the 21kW units have two PMVs in parallel.

### 4.3.6 - Moisture indicator

Located on the liquid line, this indicator permits monitoring of the unit charge and indicates moisture in the circuit. The presence of bubbles in the sight-glass can indicate an insufficient charge or non-condensables in the system. The presence of moisture changes the colour of the indicator paper in the sight-glass.

### 4.3.7 - Filter drier

This is a one-piece, brazed filter drier, located in the liquid line. The role of the filter drier is to keep the circuit clean and moisture-free. The moisture indicator shows when it is necessary to change the filter drier. The filter drier is a bi-flow device on the 30RQV units that means that it filters and dehydrates in both operating modes. The pressure drop is much higher in the heating mode. A difference in temperature between the filter inlet and outlet shows that the element is dirty.

### 4.3.8 - Water evaporator/condenser

The evaporator/condenser is a plate heat exchanger. The water connection of the heat exchanger is a threaded connection. It has a thermal insulation of 6 and 13 mm thick polyurethane foam and includes frost protection, as standard.

The products that may be added for thermal insulation of the containers during the water piping connection procedure must be chemically neutral in relation to the materials and coatings to which they are applied. This is also the case for the products originally supplied by the manufacturer.

#### NOTES - Monitoring during operation:

- Follow the regulations on monitoring pressurised equipment.
- It is normally required that the user or operator sets up and maintains a monitoring and maintenance file.
- If there are no regulations or to complement them follow the control programmes of EN 378 or ISO 5149.
- If they exist follow local professional recommendations.
- Regularly check for possible presence of impurities (e.g. silica grains) in the heat exchange fluids. These impurities maybe the cause of the wear or corrosion by puncture.
- The reports of periodical checks by the user or operator must be included in the supervision and maintenance file.

### 4.3.9 - Refrigerant

30RBV/RQV units operate with refrigerant R-410A.

### 4.3.10 - High-pressure safety switch

30RBV/RQV units are equipped with automatically reset safety pressure switches on the high-pressure side. For the alarm acknowledgement procedures, refer to § 6. Alarm description.

### 4.3.11 - Receiver

30RQV units are equipped with mechanically welded storage tanks that stores the excess refrigerant when the unit operates in heating mode.

### 4.3.12 - Four-way valve

For 30RQV units, this device permits the reversal of the refrigeration cycle to allow operation in cooling mode, in heating mode, and during defrost cycles.

### 4.3.13 - Inverter subassembly for compressor and fans

The 30RBV/RQV units are fitted with Inverter modules to control the compressor and the fan motors.

### 4.3.14 - Accumulator

The 30RBV/RQV units are fitted with an accumulator in the compressor suction line to prevent liquid carry-over to the compressor, particularly during defrost cycle and transient operations.

## 5 - MAINTENANCE

### 5.1 - Standard maintenance

To ensure optimal efficiency and reliability of the units, we recommend establishing a maintenance contract with your local Service organisation. This contract will include regular inspections by Service specialists so that any malfunction is detected and corrected quickly, ensuring that no serious damage can occur.

A Service maintenance contract is the best way to ensure the maximum operating life for your equipment and, through the expertise of technicians, provides the ideal way to manage your system cost effectively. Air conditioning equipment must be maintained by professional technicians, whilst routine checks can be carried out locally by specialised technicians. See the standard EN 378-4 or ISO5149.

**All refrigerant charging, removal and draining operations must be carried out by a qualified technician and with the correct material for the unit. Any inappropriate handling can lead to uncontrolled fluid or pressure leaks.**

#### **CAUTION:**

**Before doing any work on the machine ensure that the power is switched off. If a refrigerant circuit is opened, it must be evacuated, recharged and tested for leaks. Before any operation on a refrigerant circuit, it is necessary to remove the complete refrigerant charge from the unit with a refrigerant charge recovery group.**

**Simple preventive maintenance will allow you to get the best performance from your HVAC unit:**

- improved cooling and heating performance
- reduced power consumption
- prevention of accidental component failure
- prevention of major time-consuming and costly interventions
- protection of the environment

There are five maintenance levels for HVAC units, as defined by the AFNOR X60-010 standard.

#### **NOTE:**

**Any deviation or non-observation of these maintenance criteria will render the guarantee conditions for the HVAC unit null and void, and the manufacturer, will no longer be responsible.**

#### 5.1.1 - Level 1 maintenance

**See note in §5.1.3 Level 3.**

Simple procedures can be carried out by the user on a weekly basis:

- Visual inspection for oil traces (sign of a refrigerant leak),
- Air heat exchanger cleaning - see §5.4 Air heat exchanger,
- Check for removed protection devices, and badly closed panels,
- Check the unit alarm report when the unit does not work (refer to WUI end user manual),
- General visual inspection for any signs of deterioration,
- Verify the charge in the sight-glass.

Check that the water temperature difference between the heat exchanger inlet and outlet is correct.

#### 5.1.2 - Level 2 maintenance

This level requires specific know-how in the electrical, hydraulic and mechanical fields.

The frequency of this maintenance level can be monthly or annually depending on the verification type.

In these conditions, the following maintenance operations are recommended.

Carry out all level 1 operations, then:

##### **Electrical checks**

- At least once a year tighten the power circuit electrical connections (refer to § 5.2 and 5.3 Tightening torques for the main electrical connections and main bolts and screws).
- Check and retighten all control/command connections, if required (refer to § 5.2 and 5.3 Tightening torques for the main electrical connections and main bolts and screws).
- Remove the dust and clean the interior of the control boxes, if required.
- Check the status of the contactors, disconnect switches and capacitors.
- Check the presence and the condition of the electrical protection devices.
- Check the correct operation of all electric heaters.
- Check that no water has penetrated into the control box.

##### **Mechanical checks**

- Check the tightening of the fan tower, fan, compressor and control box fixing bolts.

##### **Water circuit checks**

- Always take care when working on the water circuit to ensure that the condenser close by is not damaged.
- Check the water connections.
- Check the expansion tank for signs of excessive corrosion or gas pressure loss and replace it, if necessary.
- Purge the water circuit (see §2.5 Water flow rate control).
- Clean the water filter (see §2.5 Water flow rate control).
- Examine the fixed speed pump bearing after 17500 hours of operation with water and the fixed speed pump mechanical seal after 15000 hours. Check the operation of the low water flow rate safety device.
- Check the status of the thermal piping insulation.
- Check the concentration of the anti-freeze protection solution (ethylene glycol or propylene glycol).

##### **Refrigerant circuit**

- Fully clean the air heat exchangers with a low-pressure jet and a bio-degradable cleaner.
- Check the unit operating parameters and compare them with previous values.
- Carry out an oil contamination test.
- Check the operation of the high-pressure switch. Replace it if there is a fault.
- Check the fouling of the filter drier. Replace it if necessary.
- Keep and maintain a maintenance sheet, attached to each HVAC unit.

**All these operations require strict observation of adequate safety measures: individual protection garments, compliance with all industry regulations, compliance with applicable local regulations and using common sense.**

## 5 - MAINTENANCE

### 5.1.3 - Level 3 (or higher) maintenance

The maintenance at this level requires specific skills/approval/tools and know-how and only the manufacturer, his representative or authorised agent are permitted to carry out these operations. These maintenance operations concern for example:

- A major component replacement (compressor, evaporator),
- Any intervention on the refrigerant circuit (handling refrigerant),
- Changing of parameters set at the factory (application change),
- Removal or dismantling of the HVAC unit,
- Any intervention due to a missed established maintenance operation,
- Any intervention covered by the warranty.
- One to two leak checks per year with a certified leak detector and carried out by a qualified person.

**To reduce waste, the refrigerant and the oil must be transferred in accordance with applicable regulations, using methods that limit refrigerant leaks and pressure drops and with materials that are suitable for the products.**

**Any detected leaks must be repaired immediately.**

**The compressor oil that is recovered during maintenance contains refrigerant and must be treated accordingly.**

**Refrigerant under pressure must not be purged to the open air.**

**If a refrigerant circuit is opened, plug all openings, if the operation takes up to one day, or for longer periods charge the circuit with nitrogen.**

**NOTE:**

**Any deviation or non-observation of these maintenance criteria will render the guarantee conditions for the HVAC unit null and void, and the manufacturer will no longer be held responsible.**

### 5.2 - Tightening torques for the main electrical connections

Component	Designation in the unit	Value (N.m)
Disconnecting switch (option)	L1 /L2 /L3/N/PE	2
Terminal Bloc X1	L1 /L2 /L3/N/PE	1,5 to 1,8
Terminal Bloc X3		0,6 to 0,8
Contacteur (Power and control)		1,5
Thermal relay		2,5
Transformer		1,7
<b>Connections on compressor</b>		
Screw on phases (Only for 21kW)		2,5
<b>Compressor variable speed drive</b>		
6 M10 nuts	L1 /L2 /L3/N	1,2
2 M10 or M8 nuts	PE	1,2
9 M8 nuts (with fuses and busbars)	1/2/3	1,2

### 5.3 - Tightening torques for the main bolts and screws

Screw Type	Utilisation	Value (N.m)
M8 H Wood screw	Chassis fixing to shipping pallet	13
M8 H nut	Compressor fixing to base pan BPHE & Receiver fixing	15
Taping screw D=4,2mm	Sheet metal parts, Plastic grid & electrical components	4,2
Taping screw D=3mm	Deflector assembly on front panel	2
M6 Taping screw	Fan sub assembly & Chassis assembly on feet	7
M8 Screw	Water pump assembly on the partition panel	15
D1" & D1"1/4" Gas nut	Water pump inlet and outlet pipe connections	70
D1/2" Gas nut	Water filling system & nut assembly on inlet water pump pipe	20
M6 H nut	Fan propellers assembly on fan motor	7

### 5.4 - Air heat exchanger

We recommend, that finned coils are inspected regularly to check the degree of fouling. This depends on the environment where the unit is installed, and will be worse in urban and industrial installations and near trees that shed their leaves.

For coil cleaning, two maintenance levels are used, based on the AFNOR X60-010 standard:

- If the air heat exchangers are fouled, clean them gently in a vertical direction, using a brush.
- Only work on air heat exchangers with the fans switched off.
- For this type of operation switch off the HVAC unit if service considerations allow this.
- Clean air heat exchangers guarantee optimal operation of your HVAC unit. This cleaning is necessary when the air heat exchangers begin to become fouled. The frequency of cleaning depends on the season and location of the HVAC unit (ventilated, wooded, dusty area, etc.).

Clean the coil, using appropriate products. We recommend products for coil cleaning:

- Carrier Part No. 00PSP000000115A: traditional cleaning method.

**CAUTION:**

**Never use pressurised water without a large diffuser. Do not use high-pressure cleaners for Cu/Cu and Cu/Al coils.**

**Concentrated and/or rotating water jets are strictly forbidden. Never use a fluid with a temperature above 45°C to clean the air heat exchangers.**

**Correct and frequent cleaning (approximately every three months) will prevent 2/3 of the corrosion problems.**

### 5.5 - Water heat exchanger maintenance

Check that:

- the insulating foam is intact and securely in place.
- the BPHE and piping electric heaters are operating, secure and correctly positioned.
- the water-side connections are clean and show no sign of leakage.

## 5 - MAINTENANCE

### 5.6 - Unit maintenance

**CAUTION:**

**Before any work on the unit ensure that the circuit is isolated and there is no voltage present. Note that it may take 5 minutes for the circuit capacitors to fully discharge after isolating the circuit. Only appropriately qualified personnel are authorised to work on the VFD.**

In case of any alarm or persistent problem related to the VFD, contact Service.

The VFDs fitted with 30RBV/RQV units do not require an insulation test, even if being replaced; they are systematically verified before delivery. Moreover, the filtering components installed in the VFD can falsify the measurement and may even be damaged. If there is a need to test the insulation of the unit components (fan motors and pumps, cables, etc.), the VFD must be disconnected at the power circuit.

### 5.7 - Refrigerant volume

The unit must be operated in cooling mode to find out, if the unit charge is correct, by checking the actual subcooling.

Following a small refrigerant leak a loss of refrigerant, compared to the initial charge will be noticeable in the cooling mode and affect the subcooling value obtained at the air heat exchanger (condenser) outlet, but it will not be noticeable in the heating mode.

**IMPORTANT:**

**It is therefore not possible to optimise the refrigerant charge in the heating mode after a leak. The unit must be operated in the cooling mode to check, if an additional charge is required.**

### 5.8 - Characteristics of R-410A

Saturated temperatures based on the gauge pressure (in kPag)					
Saturated Temp. °C	Gauge pressure, kPag	Saturated Temp. °C	Gauge pressure, kPag	Saturated Temp. °C	Gauge pressure, kPag
-20	297	11	1020	42	2429
-19	312	12	1053	43	2490
-18	328	13	1087	44	2551
-17	345	14	1121	45	2614
-16	361	15	1156	46	2678
-15	379	16	1192	47	2744
-14	397	17	1229	48	2810
-13	415	18	1267	49	2878
-12	434	19	1305	50	2947
-11	453	20	1344	51	3017
-10	473	21	1384	52	3088
-9	493	22	1425	53	3161
-8	514	23	1467	54	3234
-7	535	24	1509	55	3310
-6	557	25	1596	56	3386
-5	579	26	1552	57	3464
-4	602	27	1641	58	3543
-3	626	28	1687	59	3624
-2	650	29	1734	60	3706
-1	674	30	1781	61	3789
0	700	31	1830	62	3874
1	726	32	1880	63	3961
2	752	33	1930	64	4049
3	779	34	1981	65	4138
4	807	35	2034	66	4229
5	835	36	2087	67	4322
6	864	37	2142	68	4416
7	894	38	2197	69	4512
8	924	39	2253	70	4610
9	956	40	2311		
10	987	41	2369		

The units use high-pressure R-410A refrigerant (the unit operating pressure is above 40 bar, the pressure at 35°C air temperature is 50% higher than for R-22). Special equipment must be used when working on the refrigerant circuit (pressure gauge, charge transfer, etc.).

## 6 - ALARM DESCRIPTION

The following tables of alarms list their probable cause and the likely effect on the unit, as well as the reset type.

**Table 10: Alarms listing**

Alarm [P344]	Current Alarm [P350] to [P354] Past Alarm [P360] to [P364]	Description	Unit Status	Reset type		Investigation / corrective actions	
				Automatic	Power cycle		
				Comment			
-	1	EWT sensor failure	Continue	X		When value returns within correct range	1. Check EWT sensor (EWT). 2. Check NHC board.
-	2	LWT sensor failure	Stop	X		When value returns within correct range	1. Check LWT sensor (LWT). 2. Check NHC board.
-	3	Refrigerant Temperature (TR) sensor failure	Cpr stop	X		When value returns within correct range	1. Check TR sensor (TR). 2. Check NHC board.
-	4	OAT sensor failure	Continue	X		When value returns within correct range	1. Check Additional OAT sensor (OAT). 2. Check NHC board.
-	5	DHW_TT sensor failure	DHW Failed	X		When value returns within correct range	1. Check DHW sensor (DHW). 2. Check NHC board.
-	6	CHWSTEMP sensor failure		X		When value returns within correct range	1. Check CHWSTEMP sensor (CHWSTEMP). 2. Check NHC board.
-	7	IAT sensor failure	Continue	X		When value returns within correct range	1. Check IAT sensor (IAT). 2. Check NHC board.
-	8	UI Indoor Temperature failure	Continue	X		When value returns within correct range	1. Check UI Indoor Temp sensor. 2. Check NHC board.
-	9	Spare Sensor failure	Continue	X		When value returns within correct range	1. Check Spare sensor. 2. Check NHC board."
100	10	Inverter Discharge Temperature (TD) sensor failure	Cpr stop		X	Error becomes definite after retrying operation for 4 times.	1. Check discharge temp. sensor (TD).
102	11	Inverter Air Exchanger Temperature (TE) sensor failure	Cpr stop		X	Error becomes definite after retrying operation for 4 times.	1. Check temp. sensor (TE).
103	12	Inverter Liquid Temperature (TL) sensor failure	Cpr stop		X	Error becomes definite after retrying operation for 4 times.	1. Check temp. sensor (TL).
104	13	Inverter TO sensor failure	Continue		X	Unit operation continues in backup mode. TO sensor value fixed to 30°C in cooling, 10°C in heating. Backup mode is cancelled when any other value is detected by TO sensor.	1. Check outside temp. sensor (TO).
108	14	Inverter Suction Temperature (TS) Sensor failure	Cpr stop		X	Error becomes definite after retrying operation for 4 times.	1. Check suction temp. sensor (TS).
109	15	Inverter Heatsink Temperature failure	Cpr stop		X	Error becomes definite after retrying operation for 8 times.	1. Check correct fan operation
111	16	Inverter TE & TS sensors wrongly connected	Cpr stop		X	Error becomes definite after retrying operation for 4 times.	1. Check temp. sensor (TE, TS).
119	17	Inverter Suction Pressure (PS) sensor failure	Cpr stop		X	Error becomes definite after retrying operation for 2 times for disconnection detection and 4 times for high pressure.	1. Check Suction Pressure sensor (LP).
-	20	Loss of communication with UI	Continue	X		When a new message is received from the UI	
-	21	Loss of communication with Inverter	Cpr stop	X		When a new message is received from the Inverter	
221	22	Communication failure between Inverter's boards	Cpr stop		X	Only delay of communication.	
-	23	Loss of communication with Slaves	Master continues	X			
-	24	Loss of communication with Master	Stop	X			
-	25	Loss of communication with Jbus Master	Stop	X		When a new valid message is received from the Jbus Master	
-	31	Safety Input	Unit stop OR Heat stop OR Cool stop	X		When Safety Input is closed	

## 6 - ALARM DESCRIPTION

Alarm [P344]	Current Alarm [P350] to [P354] Past Alarm [P360] to [P364]	Description	Unit Status	Reset type		Investigation / corrective actions	
				Automatic	Power cycle		
				Comment			
-	32	Flow Switch failure	Cpr stop		X	Error becomes definite after retrying operation for 5 times.	
228	33	Inverter High Pressure Release failure	Cpr stop		X	Error detected when discharge pressure exceeds HP switch limit pressure.	<ol style="list-style-type: none"> <li>1. Check of outdoor fan operation.</li> <li>2. Check motor error of outdoor fan.</li> <li>3. Check clogging of outdoor PMV.</li> <li>4. Check clogging of heat exchanger.</li> <li>5. Check for re-cycling of air around air heat exchanger.</li> </ol>
-	50	Exchanger Freeze Protection on Water Temp (in Cooling)	Stop	X		Energized Cooler Heater while alarm is active. Force pump to run.	
-	51	Exchanger Freeze Protection on Refrigerant Temp (in Cooling)	Stop		X	Energized Cooler Heater while alarm is active. Force pump to run until alarm reset kind becomes manual. Error becomes definite after retrying operation more than 12 occurrences within a 2 hours period	
243	60	Reversing Valve Protection	Cpr stop		X	Error becomes definite after retrying operation for 4 times.	<ol style="list-style-type: none"> <li>1. Check operation of 4-way valve.</li> <li>2. Check air heat exchanger (TE), suction temp. sensor (TS).</li> <li>3. Check BPHE sensor (TR).</li> <li>4. Check 4-way valve coil.</li> <li>5. Check PMV (Pulse Motor Valve).</li> </ol>
246	61	Fan error	Cpr stop		X	Error becomes definite after retrying operation for 8 times. Error detected in either of the following condition; 1) Fan motor lock 2) Fan motor IPM over current at start up 3) Fan IPDU DC voltage abnormal	<ol style="list-style-type: none"> <li>1. Check lock of fan motor.</li> <li>2. Check power supply voltage between L2 and N.</li> </ol>
250	62	Compressor inverter short circuit protection	Cpr stop		X	Error becomes definite after retrying operation for 8 times. Error detected in either of the following condition; 1) Compressor IPM short circuit detection at start up 2) Compressor IPM short circuit detection during coil heating	
253	63	Compressor motor position detection error	Cpr stop		X	Error becomes definite after retrying operation for 8 times. Error detected when offset voltage of motor current sensor is abnormal before compressor start up.	
129	64	Compressor breakdown	Cpr stop		X	Error becomes definite after retrying operation for 8 times. Error detected in either of the following condition; 1) Compressor over current 2) Compressor IPM short circuit 3) Compressor motor control failure	<ol style="list-style-type: none"> <li>1. Check power supply voltage.</li> <li>2. Overload operation of refrigerating cycle</li> </ol>
130	65	Compressor lock	Cpr stop		X	Error becomes definite after retrying operation for 8 times. Error detected in either of the following condition; 1) Compressor motor lock 2) Compressor motor IPM over current at start up	<ol style="list-style-type: none"> <li>1. Trouble of compressor (Lock, etc.): Replace compressor.</li> <li>2. Wiring error of compressor (Open phase)</li> </ol>

## 6 - ALARM DESCRIPTION

Alarm [P344]	Current Alarm [P350] to [P354] Past Alarm [P360] to [P364]	Description	Unit Status	Reset type		Investigation / corrective actions
				Automatic	Power cycle	
				Comment		
132	70	Compressor Thermal Switch Release failure	Cpr stop		X	Error becomes definite after retrying operation for 10 times. 1. Check case thermostat and connector. 2. Check gas leak, recharge 3. Check PMV (Pulse Motor Valve). 4. Check broken pipe.
134	71	Suction Pressure Too Low	Cpr stop		X	Error becomes definite after retrying operation for 8 times. 1. Check clogging of outdoor PMV. 2. Check 2-way valve circuit. 3. Check Ps sensor error (LP). 4. Check clogging of refrigerant filter. 5. Check clogging of refrigerant pipe. 6. Check of fan operation (In heating mode). 7. Check short of refrigerant.
244	72	High Pressure System error (Pressure Switch, Compressor Case Temperature, Power Supply)	Stop		X	Error becomes definite after retrying operation for 10 times. 1. Check outdoor heat exchanger sensor (TL). 2. Check fan. 3. Check PMV (Pulse Motor Valve). 4. Check clogging and short circuit of heat exchanger. 5. Overcharge of refrigerant. Recharge
131	73	Current detection circuit error	Cpr stop		X	Error becomes definite after retrying operation for 8 times. Error detected in either of the following condition; 1) Motor current sensor failure
227	74	Discharge Temperature too high	Cpr stop		X	Error becomes definite after retrying operation for 4 times. 1. Check refrigerant circuit (Gas leak). 2. Check electronic expansion valve. 3. Check discharge temp. sensor (TD).
229	75	Missing phase in power cable	Cpr stop		X	Error becomes definite after retrying operation for 8 times. 1. Check power supply voltage.
231	76	Inverter Heatsink Temperature too high	Cpr stop		X	Error becomes definite after retrying operation for 4 times. 1. Check heat sink airflow path.
-	80	Real Time Clock Failure on NHC board	Continue	X		
-	81	EEPROM corrupted on NHC board	Continue		X	
127	82	Inverter EEPROM not readable or EEPROM number out of range	Stop		X	Only delay of communication.
-	90	Invalid Configuration	Stop	X		Automatic when configuration is correct
-	91	Wrong unit type	Stop	X		Automatic when configuration is correct
-	92	Wrong unit size for this brand	Stop	X		Automatic when configuration is correct
-	93	Wrong supply type	Stop	X		Automatic when configuration is correct
-	94	Wrong mounting type	Stop	X		Automatic when configuration is correct
-	95	Wrong CDU capacity from Inverter	Stop	X		Automatic when configuration is correct
-	96	Wrong hydronic configuration	Stop	X		Automatic when configuration is correct
-	97	Wrong compressor map selection	Stop	X		Automatic when configuration is correct
-	98	Wrong configuration in Master/Slave	Stop	X		Automatic when configuration is correct
-	99	Wrong addressing in Master/Slave	Stop	X		Automatic when configuration is correct
-	100	Emergency stop	Stop	X		Automatic when [P055] is reset
-	200	External Alarm	Continue	X		When contact is closed
-	78	Other inverter error	Continue	X		
-	79	Unknowned inverter error	Continue	X		

## 7 - PARAMETERS OVERVIEW

This section includes an overview of all parameters that can be read or modified by the user.

**The parameters are sorted as follows:**

- 001 to 299 Display parameters
- 301 to 399 Maintenance parameters
- 401 to 499 Setpoint parameters
- 501 to 799 Configuration parameters

**Legend:**

No No access  
 RO Read-Only  
 RW Read/Write  
 RO/d Read-Only and Display on the WUI  
 RO/F Read-Only and Parameter Forcing by CCN

Par.	Jbus	Mnemonic	Description	Range	Default	Unit	WUI	CCN	Table
001	0001H	OAT	Outdoor Air Temperature			1/10°C	RO/d	RO/F	GENUNIT
002	0002H	IAT	Indoor Air Temperature			1/10°C	RO/d	RO/F	GENUNIT
003	0003H	EWT	Entering Water Temperature			1/10°C	RO	RO/F	GENUNIT
004	0004H	LWT	Leaving Water Temperature			1/10°C	RO	RO/F	GENUNIT
005	0005H	TR	Refrigerant Temperature			1/10°C	RO	RO/F	GENUNIT
006	0006H	SPARE_T	Spare Temperature			1/10°C	RO	RO/F	GENUNIT
007	0007H	roomtemp	Room Temperature			1/10°C	RO	RO/F	GENUNIT
008	0008H	sst	Saturated Suction Temp			1/10°C	RO	RO	GENUNIT
009	0009H	ts	Suction Temperature			1/10°C	RO	RO	GENUNIT
010	000AH	td	Discharge Temperature			1/10°C	RO	RO	GENUNIT
011	000BH	te	Lower Air Exchanger Temp			1/10°C	RO	RO	GENUNIT
012	000CH	tl	Upper Air Exchanger Temp			1/10°C	RO	RO	GENUNIT
013	000DH	to	Inv. Outdoor Air Temp			1/10°C	RO	RO	GENUNIT
014	000EH	th	Heatsink Temperature			1/10°C	RO	RO	GENUNIT
015	000FH	sh	Superheat Temperature			1/10 K	RO	RO	GENUNIT
016	0010H	sh_targ	Superheat Target Temp			1/10 K	RO	RO	GENUNIT
017	0011H	dc_volt	Inverter DC High Voltage			V	RO	RO	GENUNIT
018	0012H	hv_stat	HV Bus Comm. Status	0/1 [Normal/Alarm]		-	RO	RO	GENUNIT
019	0013H	inv_mod	Inverter Current Mode			-	RO	RO	GENUNIT
020	0014H	freq_min	Actual Min Compr. Freq			1/10 Hz	RO	RO	GENUNIT
021	0015H	freq_max	Actual Max Compr. Freq			1/10 Hz	RO	RO	GENUNIT
022	0016H	FREQ_REQ	Requested Compr. Freq			1/10 Hz	RO	RO/F	GENUNIT
023	0017H	freq_cur	Actual Compressor Freq			1/10 Hz	RO	RO	GENUNIT
024	0018H	pmv_pos	PMV Position	0 to 500		step	RO	RO	GENUNIT
025	0019H			N.A.					
026	001AH			N.A.					
027	001BH	upr_fan	Upper Fan Speed	0 to 1000		rpm	RO	RO	GENUNIT
028	001CH	lwr_fan	Lower Fan Speed	0 to 1000		rpm	RO	RO	GENUNIT
029	001DH	EXCH_HTR	Exchanger Heater	0/1 [Off/On]		-	RO	RO/F	GENUNIT
030	001EH	BOILER	Boiler Output	0/1 [Off/On]		-	RO	RO/F	GENUNIT
031	001FH	EHS	Electrical Heat Stages	0 to 3		-	RO	RO/F	GENUNIT
035		SPARE_P	Spare Pressure			KPa	RO	RO/F	GENUNIT
039*	0027H	to2	Corrected Inverter TO			1/10°C	RO	RO	GENUNIT
041	0029H	CHIL_OCC	Occupancy Mode	0 to 2 [Away/ Sleep/ Home]		-	RW/d	RW/F	STATUS
042	002AH	sum_mode	Summer Mode	0/1 [No/Yes]		-	RO	RO	STATUS
043	002BH	nightmod	Night Mode	0/1 [No/Yes]		-	RO	RO	STATUS
044	002CH	MOD_REQ	System Mode Request	0 to 9		-	RW/d	RW/F	STATUS
045	002DH	MOD_STAT	System Mode Status	0 to 109		-	RO/d	RO	STATUS
046	002EH			N.A.					
047	002FH	mod_ovr	System Mode Override	0 to xxx		-	RO	RO	STATUS
048	0030H	setpoint	Current Setpoint	0.0 to 60.0		1/10°C	RW/d	RO	STATUS
049	0031H	RESET	User Adjust Temperature	-5.0 to 5.0		1/10 K	RO	RO/F	STATUS
050	0032H	IAT_OFF	IAT Offset	-4.0 to 4.0		1/10 K	RO	RO/F	STATUS
051	0033H	CTRL_PNT	Control Point	0.0 to 60.0		1/10°C	RO/d	RO/F	STATUS OR MSL_STAT
052	0034H	CTRL_TMP	Control Temp	-40.0 to 115.0		1/10°C	RO/d	RO/F	STATUS
053				N.A.					
061	003DH	cmp_req	Compressor Mode Request			-	RO	RO	LOADFACT
062		cmp_inv	Compressor Mode To Inv.			-	RO	RO	LOADFACT
063	003FH	cmp_stat	Compressor Mode Status			-	RO	RO	LOADFACT



## 7 - PARAMETERS OVERVIEW

Par.	Jbus	Mnemonic	Description	Range	Default	Unit	WUI	CCN	Table
064	0040H	cap_ovr	Capacity Override			-	RO	RO	LOADFACT
065	0041H	cap_tmr	Capacity Timer			s	RO	RO	LOADFACT
066	0042H	CAP_T	Total Capacity	0 to 100		%	RO	RO/F	LOADFACT
067	0043H	DEM_LIM	Demand Limit	0 to 100		%	RO	RO/F	LOADFACT
068	0044H	FREQ_RED	Frequency Reduction Mode	0/1 [No/Yes]		-	RO	RO/F	LOADFACT
069	0045H	RUNNING	Unit Running Status	0/1 [No/Yes]		-	RO	RO/F	LOADFACT
081	0051H	pmp_ovr	Pump Override	-1 to 19		-	RO	RO	PMP_STAT
082	0052H	flow_err	Water Flow Failure	0/1 [Normal/Alarm]		-	RO	RO	PMP_STAT
083	0053H	dtstp	Current DeltaT Setpoint			1/10 K	RO	RO	PMP_STAT
084	0054H	delta_t	Water Delta Temperature			1/10 K	RO	RO	PMP_STAT
085	0055H	PMP	Water Pump Speed	0 to 100		%	RO	RO/F	PMP_STAT
088	0058H	ADD_PMP	Additional Pump Output	0/1 [Off/On]		-	RO	RO/F	PMP_STAT
091	005BH	Backup_ovr	Backup Override	-1 to 100	N.A.	-	RO	RO	BCK_STAT
092	005CH	back_flg	Backup Authorized flag	0 to 1	N.A.	-	RO	RO	BCK_STAT
093	005DH	warmtime	Booster Warm Up timer	0 to 1800	N.A.	s	RO	RO	BCK_STAT
094	005EH	BACK_CAP	Backup Capacity	0 to 100	N.A.	%	RO	RO/F	BCK_STAT
101	0065H	ONOFF_SW	On/Off Switch Status	0/1 [Open/Close]		-	RO	RO/F	INPUT
102	0066H	HC_SW	Heat/Cool Switch Status	0/1 [Open/Close]		-	RO	RO/F	INPUT
103	0067H	ECO_SW	Eco Switch Status	0/1 [Open/Close]		-	RO	RO/F	INPUT
104	0068H	SAFE_SW	Safety Switch Status	0/1 [Open/Close]		-	RO	RO/F	INPUT
105	0069H	FLOW_SW	Flow Switch Status	0/1 [Open/Close]		-	RO	RO/F	PMP_STAT OR INPUT
106	006AH	CUST_DI5	Customized DI#5 Status	0/1 [Open/Close]		-	RO	RO/F	INPUT
107	006BH	CUST_DI6	Customized DI#6 Status	0/1 [Open/Close]		-	RO	RO/F	INPUT
108	006CH	CUST_DI7	Customized DI#7 Status	0/1 [Open/Close]		-	RO	RO/F	INPUT
109	006DH	CUST_DI8	Customized DI#8 Status	0/1 [Open/Close]		-	RO	RO/F	INPUT
110	006EH	RED_SW	Power Limitation Switch	0/1 [Open/Close]		-	RO	RO/F	INPUT
111	006FH	OPEAK_SW	Off Peak Hour Switch	0/1 [Open/Close]		-	RO	RO/F	INPUT
112	0070H	LSHED_SW	Loadshed Request Switch	0/1 [Open/Close]		-	RO	RO/F	INPUT
113	0071H	SOLAR_SW	Solar Input Switch	0/1 [Open/Close]		-	RO	RO/F	INPUT
114	0072H	DHW_REQ	DHW Request from tank	0/1 [Open/Close]		-	RO	RO/F	INPUT OR DHW_STAT
115	0073H	DHW_PRIO	DHW Priority Switch	0/1 [Open/Close]		-	RO	RO/F	INPUT OR DHW_STAT
116	0074H	DHW_ANTI	DHW Anti-Legionella Req.	0/1 [Open/Close]		-	RO	RO/F	INPUT OR DHW_STAT
117	0075H	SUMM_SW	Summer Switch	0/1 [Open/Close]		-	RO	RO/F	INPUT OR DHW_STAT
118	0076H			N.A.					
119	0077H			N.A.					
120	0078H	EXALM_SW	External Alarm Switch	0/1 [Open/Close]		-	RO	RO/F	INPUT
201	00C9H	DHW_MODE	DHW Mode	0 to 2 [Eco/ Anti-Leg. / Regular]		-	RW	RO/F	DHW_STAT
202	00CAH	dhw_ovr	DHW Override	-1 to 100		-	RO	RO	DHW_STAT
203	00CBH	dhw_dem	DHW Demand from Tank	0/1 [No/Yes]		-	RO	RO	DHW_STAT
204	00CCH	dhw_cond	DHW Conditions	0/1 [True/False]		-	RO	RO	DHW_STAT
205	00CDH	DHW_CTLP	DHW Control Point	30.0 to 60.0		1/10°C	RO	RO/F	DHW_STAT
206	00CEH	DHW_TT	DHW Tank Temperature			1/10°C	RO	RO/F	DHW_STAT
207	00CFH	shc_time	Current SHC Runtime			min	RO	RO	DHW_STAT
208	00D0H	dhw_time	Current DHW Runtime			min	RO	RO	DHW_STAT
209	00D1H	DHW_EXCP	DHW Exception Timer	0 to 1440		min	RO	RO/F	DHW_STAT
210	00D2H	DHW_VLV	DHW Diverting Valve	0/1 [Off/On]		-	RO	RO/F	DHW_STAT
211	00D3H	DHW_EHS	DHW Elec Heat Stage	0/1 [Off/On]		-	RO	RO/F	DHW_STAT
212	00D4H	DHW_RUN	DHW Running Status	0/1 [No/Yes]		-	RO	RO/F	DHW_STAT
221	00DDH	CHWSTEMP	Chiller Water System Temp			1/10°C	RO	RO/F	MSL_STAT
222	00DEH	ms_cap	Mast/Slv Total Capacity	0 to 100	0	%	RO	RO	MSL_STAT
223		mst_req	Master Request Capacity	0 to 100	0	%	RO	RO	MSL_STAT
224		slv1_req	Slave #1 Request Capa.	0 to 100	0	%	RO	RO	MSL_STAT
225		slv2_req	Slave #2 Request Capa.	0 to 100	0	%	RO	RO	MSL_STAT
226		slv3_req	Slave #3 Request Capa.	0 to 100	0	%	RO	RO	MSL_STAT
227				N.A.					
228		ms_activ	Mast/Slv Active Flag	False/True	False	-	RO	RO	MSL_STAT
229		MS_STAT	Mast/Slv Overall Status	-1 to 101	0	-	RO	RO	MSL_STAT
230	00E6H	mast_sta	Master Status	-1 to 101		-	RO	RO	MSL_STAT
231	00E7H	slv1_sta	Slave #1 Status	-1 to 101		-	RO	RO	MSL_STAT
232	00E8H	slv2_sta	Slave #2 Status	-1 to 101		-	RO	RO	MSL_STAT
233	00E9H	slv3_sta	Slave #3 Status	-1 to 101		-	RO	RO	MSL_STAT
234	00EAH	MS_LIM	Mast/Slv Demand Limit	0 to 100	100	%	RO	RO/F	MSL_STAT
235	-	ms_prio	Mast/Slv Priority	wxyz	0	-	RO	RO	MSL_STAT

## 7 - PARAMETERS OVERVIEW

Par.	Jbus	Mnemonic	Description	Range	Default	Unit	WUI	CCN	Table
241				N.A.					
242				N.A.					
243				N.A.					
244				N.A.					
245				N.A.					
301		model	Inverter Model			-	RO	RO	Inverter
302		prg_ver	Inverter Progr Version			-	RO	RO	Inverter
303		prg_rev	Inverter Progr Revision			-	RO	RO	Inverter
304		eep_cod	Inverter EEPROM Code			-	RO	RO	Inverter
305		sw_set	Inverter Switch Setting			-	RO	RO	Inverter
306		cdu_cap	CDU Capacity	0 to 15		-	RO	RO	Inverter
307		mcu_code	MCU Code			-	RO	RO	Inverter
321		QCK_ENA	QT: Quick Test enable	0/1 [No/Yes]		-	RW	RW/F	QCK_TEST
322		_HP_TEST	QT: HP Switch Test	0 to 7 [No test/ Test requested/ Test in progress/ Test OK/ HP Test Failed due to timeout HP Test Failed due to Flow Switch Failure HP Test Failed due to Low Water Temperature HP Test Failed due to Inverter Failure]		-	RW	RW/F	QCK_TEST
323		_RAT_MOD	QT: Rating Mode	0 to 4 [Rating Off/ Rating Cool/ Rating Heat/ Ramp Cool/ Ramp Heat]		-	RW	RW/F	QCK_TEST
324		_RAT_FRQ	QT: Rating Frequency	0 to 120		1/10 Hz	RW	RW/F	QCK_TEST
325		_FAN_LOW	QT: Lower Fan Speed	0 to 1000		rpm	RW	RW/F	QCK_TEST
326		_FAN_UPP	QT: Upper Fan Speed	0 to 1000		rpm	RW	RW/F	QCK_TEST
327		_PMV_POS	QT: PMV Position	0 to 1000		-	RW	RW/F	QCK_TEST
331		_PMP	QT: Water Pump Speed	0 to 100		%	RW	RW/F	QCK_TEST
332	-	_EXH_HTR	QT: Water Exchanger Heater	0 to 1	-	-	RW	RW/F	QCK_TEST
333	-	_ADD_PMP	QT: Additional Pump	0 to 1	-	-	RW	RW/F	QCK_TEST
334	-	_SPR_REL	QT: Spare Relay (K5)	0 to 1	-	-	RW	RW/F	QCK_TEST
335		_DHW_VLV	QT: DHW Diverting Valve	0/1 [Off/On]		-	RW	RW/F	QCK_TEST
336		_BOILER	QT: Boiler or EHS1	0/1 [Off/On]		-	RW	RW/F	QCK_TEST
320		_CUSTDO5	QT: Customized DO#5	0/1 [Off/On]	-	-	RW	RW/F	QCK_TEST
337		_CUSTDO8	QT: Customized DO#8	0/1 [Off/On]		-	RW	RW/F	QCK_TEST
338		_CUSTDO9	QT: Customized DO #9	0/1 [Off/On]		-	RW	RW/F	QCK_TEST
340	0154H	ALMRESET	Alarm Reset	0/1 [No/Yes]		-	RW	RW/F	ALARM
341	0155H	ALM	Alarm Status	0/1 [Normal/Alarm]	0	-	RO/d	RO	ALARM
342	0156H	ALERT	Alarm Status	0/1 [No/Yes]	0	-	RO	RO	ALARM
343	0157H	SHUTDOWN	Shutdown Status	0/1 [No/Yes]	0	-	RO	RO	ALARM
344	0158H	inv_err	Inverter Error (Code)	0 to 255		-	RO	RO	ALARM
345		inv_erra	Inverter Error (Alpha)	"Normal" / "Xnn"		-	RO	RO	ALARM
346				N.A.					
347				N.A.					
348				N.A.					
349				N.A.					
350	015EH	alm_01	Current Alarm #1	0 to 100		-	RO	RO	ALARM
351	015FH	alm_02	Current Alarm #2	0 to 100		-	RO	RO	ALARM
352	0160H	alm_03	Current Alarm #3	0 to 100		-	RO	RO	ALARM
353	0161H	alm_04	Current Alarm #4	0 to 100		-	RO	RO	ALARM
354	0162H	alm_05	Current Alarm #5	0 to 100		-	RO	RO	ALARM
360	0168H	alm_01p	Past Alarm #1	0 to 100		-	RO	RO	ALARM
361	0169H	alm_02p	Past Alarm #2	0 to 100		-	RO	RO	ALARM
362	016AH	alm_03p	Past Alarm #3	0 to 100		-	RO	RO	ALARM
363	016BH	alm_04p	Past Alarm #4	0 to 100		-	RO	RO	ALARM
364	016CH	alm_05p	Past Alarm #5	0 to 100		-	RO	RO	ALARM
371	0173H	comp1_st	Compressor Starts Nb			-	RO	RO	RUNTIME1
372	0174H	comp1_hr	Compressor Run Hours			h	RO	RO	RUNTIME1
373	0175H	pmp_st	Water Pump Starts Nb			-	RO	RO	RUNTIME1
374	0176H	pmp_hr	Water Pump Run Hours			h	RO	RO	RUNTIME1
379				N.A.					
381	017DH	RUN2_RST	User Runtime Reset	0 to 3	0	-	RW	RW	RUNTIME2
382	017EH	comp_hr	Compressor Run Hours			h	RO	RO	RUNTIME2

## 7 - PARAMETERS OVERVIEW

Par.	Jbus	Mnemonic	Description	Range	Default	Unit	WUI	CCN	Table
383	017FH	back_hr	Backup Running Hours			h	RO	RO	RUNTIME2
384	0180H	cool_hr	Cooling Mode Hours			h	RO	RO	RUNTIME2
385	0181H	heat_hr	Heating Mode Hours			h	RO	RO	RUNTIME2
386	0182H	dhw_hr	DHW Mode Hours			h	RO	RO	RUNTIME2
387	0183H	dfrt_hr	Defrost Mode Hours			h	RO	RO	RUNTIME2
388	0184H	nrg_heat	Energy consumed in Heat			kWh	RO	RO	RUNTIME2
389	0185H	nrg_cool	Energy consumed in Cool			kWh	RO	RO	RUNTIME2
391	0187H	CHIL_S_S	Unit Start/Stop	0/1 [Stop/Start]		-	RO	RO/F	AQUASMRT
392	0188H	HC_SEL	Heat/Cool Select	0/1 [Cool/Heat]		-	RO	RO/F	AQUASMRT
393		EMSTOP	Emergency Stop	0/1 [Disable/Enable]		-	RO	RO/F	AQUASMRT
401	0191H	hwocstp	Heat Home Setpoint (Water)	20.0 to 60.0	45	1/10°C	RW	RW	WAT_STP
402	0192H	hwunooft	Heat Sleep Offset (Water)	-10.0 to 0.0	0.0	1/10 K	RW	RW	WAT_STP
403	0193H	hwecooff	Heat Away Offset (Water)	-10.0 to 0.0	-5.0	1/10 K	RW	RW	WAT_STP
404	0194H	N.A.							
405	0195H	leg_stp	DHW Anti-Legionella Stp	50.0 to 60.0	60	1/10°C	RW	RW	WAT_STP
406	0196H	dhw_stp	DHW Setpoint	30.0 to 60.0	50	1/10°C	RW	RW	WAT_STP
407	0197H	cwocstp	Cool Home Setpoint (Water)	0.0 to 18.0	12	1/10°C	RW	RW	WAT_STP
408	0198H	cwunooft	Cool Sleep Offset (Water)	0.0 to 10.0	0	1/10 K	RW	RW	WAT_STP
409	0199H	cwecooff	Cool Away Offset (Water)	0.0 to 10.0	5	1/10 K	RW	RW	WAT_STP
410		hw_hyst	Heat Hysteresis (Water)	0.5 to 2.0	0,5	1/10 K	RW	RW	WAT_STP
411		cw_hyst	Cool Hysteresis (Water)	0.5 to 2.0	0,5	1/10 K	RW	RW	WAT_STP
412		hcurvoff	Heat Curv Max Stp Offset	-5.0 to 5.0	0.0	1/10 K	RW	RW	WAT_STP
413		ccurvoff	Cool Curv Min Stp Offset	-5.0 to 5.0	0.0	1/10 K	RW	RW	WAT_STP
421	01A5H	htocstp	Heat Home Setpoint (Air)	12.0 to 34.0	19	1/10°C	RW	RW	AIR_STP
422	01A6H	htunooft	Heat Sleep Offset (Air)	-10.0 to 0.0	-2.0	1/10 K	RW	RW	AIR_STP
423	01A7H	htecooff	Heat Away Offset (Air)	-10.0 to 0.0	-4.0	1/10 K	RW	RW	AIR_STP
424	01A8H	clocstp	Cool Home Setpoint (Air)	20.0 to 38.0	26	1/10°C	RW	RW	AIR_STP
425	01A9H	clunooft	Cool Sleep Offset (Air)	0.0 to 10.0	2	1/10 K	RW	RW	AIR_STP
426	01AAH	clecooff	Cool Away Offset (Air)	0.0 to 10.0	4	1/10 K	RW	RW	AIR_STP
427	01ABH	freezstp	Home AntiFreeze Setpoint	6.0 to 12.0	6	1/10°C	RW	RW	AIR_STP
428		deltastp	Air Delta Setpoint	0.2 to 1.0	0,5	1/10 K	RW	RW	AIR_STP
429		iat_fact	IAT Reset Factor	0.0 to 2.0	0	1/10	RW	RW	AIR_STP
501		sfsw_typ	Safety Switch Type	1 to 3	1	-	RW	RW	GEN_CONF
502		cust_di5	Customized DI#5 Config	0 to 14	1	-	RW	RW	GEN_CONF
503		cust_di6	Customized DI#6 Config	0 to 14	0	-	RW	RW	GEN_CONF
504		cust_di7	Customized DI#7 Config	0 to 14	0	-	RW	RW	GEN_CONF
505		cust_di8	Customized DI#8 Config	0 to 14	0	-	RW	RW	GEN_CONF
500		Cust_do5	Customized DO#5 Config	0 to 13	1	-	RW	RW	GEN_CONF
506		Cust_do9	Customized DO#9 Config	0 to 13	1	-	RW	RW	GEN_CONF
507		Cust_do10	Customized DO#10 Config	0 to 13	2	-	RW	RW	GEN_CONF
508		tr_type	Refrigerant Temp Type	0 to 2	0	-	RW	RW	GEN_CONF
509		ewt_type	EWT Sensor Type	0 to 1	1	-	RW	RW	GEN_CONF
510		iat_type	IAT Sensor Type	0 to 3	0	-	RW	RW	GEN_CONF
511		oat_type	OAT Sensor Type	0 to 3	0	-	RW	RW	GEN_CONF
512		iat_bias	IAT Sensor Bias	-5.0 to 5.0	0.0	1/10 K	RW	RW	GEN_CONF
513		oat_bias	OAT Sensor Bias	-5.0 to 5.0	0.0	1/10 K	RW	RW	GEN_CONF
514		oat_min	Minimum OAT for Heating	-20.0 to 10.0	-20.0	1/10°C	RW	RW	GEN_CONF
515		oat_max	Maximum OAT for Heating	5.0 to 99.0	99.0	1/10°C	RW	RW	GEN_CONF
516		oat_minc	Minimum OAT for Cooling	-10.0 to 40.0 for chiller 0 to 40.0 for heat pump	0	1/10°C	RW	RW	GEN_CONF
517		freez_dt	Anti-Freeze Delta Setpoint	0.0 to 6.0	0	^C	RW	RW	GEN_CONF
518		nghtstrt	Night Mode Start Time	00:00 to 23:59	00:00	hh:mm	RW	RW	GEN_CONF
519		nghtstop	Night Mode Stop Time	00:00 to 23:59	00:00	hh:mm	RW	RW	GEN_CONF
520		sparetyp	Spare Sensor Type	0 to 5	0	-	RW	RW	GEN_CONF
521		ui_type	User Interface Type	0 to 3	0	-	RW	RW	UI_CONF
522		ui_accss	Parameter Access from UI	0 to 3	3	-	RW	RW	UI_CONF
523		ui_tmt	Interface Comm. Timeout	0 to 240	60	s	RW	RW	UI_CONF
524		ui_back	Backlight Timeout	0 to 7	2	-	RW	RW	UI_CONF
525		ui_buzz	Buzzer on key press	0/1 [No/Yes]	No	-	RW	RW	UI_CONF
526		timebrod	Interface Time Broadcast	0/1 [No/Yes]	Yes	-	RW	RW	UI_CONF
527		ser_pass	Service Password	0 to 9999	120	-	RW	RW	UI_CONF
528		usr_pass	User Password	0 to 9999	0	-	RW	RW	UI_CONF
541		powr_lim	Power Limitation value	50 to 100	75	%	RW	RW	CMP_CONF

## 7 - PARAMETERS OVERVIEW

Par.	Jbus	Mnemonic	Description	Range	Default	Unit	WUI	CCN	Table
542		ngh_t_lim	Nigh Limitation value	50 to 100	75	%	RW	RW	CMP_CONF
543		dhw_lim	DHW Limitation value	50 to 100	100	%	RW	RW	CMP_CONF
560		flui_typ	Fluid Type	1 to 2	1	-	RW	RW	PMP_CONF
561		pmp_ext	External Main Pump Ctrl	0/1 [No/Yes]	0 [No]	-	RW	RW	PMP_CONF
562		flw_chko	Flow Checked if Pump Off	0/1 [No/Yes]	1 [Yes]	-	RW	RW	PMP_CONF
563		pmp_stck	Anti-sticking function	0/1 [No/Yes]	1 [Yes]	-	RW	RW	PMP_CONF
564		sampling	Pmp Sampling Time Stby	5 to 240	15	min	RW	RW	PMP_CONF
565		pmp_log	Main Pump Logic	1 to 3	1	-	RW	RW	PMP_CONF
566		vsp_log	Var Speed Pump Logic	0 to 1	1	-	RW	RW	PMP_CONF
567		vsp_min	Minimum Pump Speed	19 to 100	19	%	RW	RW	PMP_CONF
568		vsp_max	Maximum Pump Speed	19 to 100	100	%	RW	RW	PMP_CONF
569		dt_stp	Water Delta T Setpoint	2.0 to 20.0	5	1/10 K	RW	RW	PMP_CONF
570		dt_kp	Delta T Proport. Gain	-10.000 to -0.001	-2.000	-	RW	RW	PMP_CONF
571		dt_ti	Delta T Integral Time	10 to 120	20	s	RW	RW	PMP_CONF
572		dt_ts	Delta T Sample Time	10 to 120	10	s	RW	RW	PMP_CONF
573		add_pmp	Additional Pump Logic	0 to 4	0	-	RW	RW	PMP_CONF
581		ht_curv	Heat Clim Curve Select	-1 to 12	-1	-	RW	RW	CLIMCURV
582		ht_min_a	Heat Minimum OAT	-30.0 to 10.0	-7.0	1/10°C	RW	RW	CLIMCURV
583		ht_max_a	Heat Maximum OAT	10.0 to 30.0	20	1/10°C	RW	RW	CLIMCURV
584		ht_min_w	Heat Min Water Setpoint	20.0 to 40.0	20	1/10°C	RW	RW	CLIMCURV
585		ht_max_w	Heat Max Water Setpoint	30.0 to 60.0	38	1/10°C	RW	RW	CLIMCURV
586		cl_curv	Cool Clim Curve Select	-1 to 2	-1	-	RW	RW	CLIMCURV
587		cl_min_a	Cool Minimum OAT	0.0 to 30.0	20	1/10°C	RW	RW	CLIMCURV
588		cl_max_a	Cool Maximum OAT	24.0 to 46.0	35	1/10°C	RW	RW	CLIMCURV
589		cl_min_w	Cool Min Water Setpoint	5.0 to 20.0	10	1/10°C	RW	RW	CLIMCURV
590		cl_max_w	Cool Max Water Setpoint	5.0 to 20.0	18	1/10°C	RW	RW	CLIMCURV
595		dry_stp	Drying Starting Setpoint	20.0 to 40.0	20	1/10°C	RW	RW	DRYING
596		drystep1	Drying Warm-up days	0 to 99	3	-	RW	RW	DRYING
597		drystep2	Drying Ramp-up days	0 to 99	4	-	RW	RW	DRYING
598		drystep3	Drying Hold-up days	0 to 99	4	-	RW	RW	DRYING
599	-	dry_time	Drying Runtime (hours)	-	-	hours	RO	RO	RUNTIME2
601		bck_type	Backup Type	0 to 9	0	-	RW	RW	BCK_CONF
602		bck_warm	Booster Warm Up Time	5 to 120	30	min	RW	RW	BCK_CONF
603		bck_delt	Booster Delta Temp	1.0 to 20.0	5	1/10°C	RW	RW	BCK_CONF
604		bck_oat	Booster OAT Threshold	-20 to 15	-7.0	1/10°C	RW	RW	BCK_CONF
605		ehs_kp	EHS Proport. Gain	0.001 to 10.000	2	-	RW	RW	BCK_CONF
606		ehs_ti	EHS Integral Time	10 to 60	20	s	RW	RW	BCK_CONF
607		ehs_ts	EHS Sampling Time	10 to 120	30	s	RW	RW	BCK_CONF
641		ccn_bus	CCN Element Address	1 to 239	1	-	RW	RW	30RBVRQV
642		ccn_elm	CCN Element Bus	0 to 239	0	-	RW	RW	30RBVRQV
645		ccn_bdr	Primary Baud Rate	0 to 2 [9600/19200/ 38400]	2 [38400]	-	RW	RW	30RBVRQV
646	02FBH	jbus_bdr	Secondary Baud Rate	0 to 2 [9600/19200/ 38400]	2 [38400]	-	RW	RW	30RBVRQV OR JBUSCONF
650		serialnb	Serial Number			-	RO	RO	30RBVRQV
653		pic_type	PIC Type			-	RO	RO	30RBVRQV
654		soft_ver	Software Version Number		-	-	RO	RO	
661		hod	Hour of Day	0 to 23	N.A.	-	RW	RW	TIME
662		mod	Minute of Hour	0 to 59	N.A.	-	RW	RW	TIME
663		dow	Day of Week	1 to 7 [Monday~ Sunday]	N.A.	-	RW	RW	TIME
664		hol_flag	Holiday Flags	0 to 15	N.A.	-	RW	RW	TIME
665		dom	Day of Month	1 to 31	N.A.	-	RW	RW	TIME
666		month	Month	1 to 12	N.A.	-	RW	RW	TIME
667		year	Year	0 to 99	N.A.	-	RW	RW	TIME
701		dhw_type	Domestic Hot Water Type	0 to 3	0	-	RW	RW	DHW_CONF
702		dhw_vlvr	DHW 3-way Valve run time	0 to 240	30	s	RW	RW	DHW_CONF
703		dhw_prio	Dom. Hot Water Priority	0 to 1	0	-	RW	RW	DHW_CONF
704		shc_min	SHC Minimum Runtime	0 to 720	20	min	RW	RW	DHW_CONF
707		dhw_max	DHW Maximum Runtime	-1 to 720	60	min	RW	RW	DHW_CONF
708		dhw_excp	DHW Exception Time	1 to 24	2	hour	RW	RW	DHW_CONF
709				N.A.					
710		vsp_dhw	Pump Speed in DHW	19 to 100	100	%	RW	RW	DHW_CONF
711		dhw_dow	DHW Schedule Days	0000 0000 to 1111 1110	1111 1110	-	RW	RW	DHW_CONF
712		dhw_strt	DHW Starting Time	00:00 to 23:59	21:00	hh:mm	RW	RW	DHW_CONF
713		dhw_stop	DHW Stopping Time	00:00 to 23:59	06:00	hh:mm	RW	RW	DHW_CONF

## 7 - PARAMETERS OVERVIEW

Par.	Jbus	Mnemonic	Description	Range	Default	Unit	WUI	CCN	Table
714		leg_dow	AntiLegionella Strt DOW	0000 0000 to 1111 1111	0	-	RW	RW	DHW_CONF
715		leg_time	AntiLegionella Strt Time	00:00 to 23:59	02:00	hh:mm	RW	RW	DHW_CONF
716		sum_oat	Summer Mode OAT Thrsld	15.0 to 30.0	20	1/10°C	RW	RW	DHW_CONF
717		sum_on	Summer Mode On Delay	0 to 12	0	h	RW	RW	DHW_CONF
718		sum_off	Summer Mode Off Delay	0 to 12	0	h	RW	RW	DHW_CONF
719		dhw_sens	DHW Tank Sensor Type	0 to 3	0	-	RW	RW	DHW_CONF
720		dhw_bias	DHW Tank Sensor Bias	-5.0 to 5.0	0.0	1/10 K	RW	RW	DHW_CONF
721		dhw_dt	DHW Tank Delta T	2.0 to 10.0	5	1/10 K	RW	RW	DHW_CONF
722		dhw_dt	EWT Delta T (stop DHW)	0.0 to 20.0	10	1/10 K	RW	RW	DHW_CONF
742		ms_sel	Master/Slave Selection	0 to 2	0	-	RW	RW	MSL_CONF
743		slv1_add	Slave #1 Address	0 to 239	0	-	RW	RW	MSL_CONF
744		slv2_add	Slave #2 Address	0 to 239	0	-	RW	RW	MSL_CONF
745		slv3_add	Slave #3 Address	0 to 239	0	-	RW	RW	MSL_CONF
746		cap_strt	Capa. to Start Next Unit	30 to 75	75	%	RW	RW	MSL_CONF
751		casc_typ	Cascade Type	0 to 2	1	-	RW	RW	MSL_CONF
752		ms_h_kp	M/S Heat Proport. Gain	0.001 to 10.000	0,9	-	RW	RW	MSL_CONF
753		ms_h_ti	M/S Heat Integral Time	10 to 120	30	s	RW	RW	MSL_CONF
754		ms_h_ts	M/S Heat Sampling Time	10 to 120	30	s	RW	RW	MSL_CONF
755		mslc_kp	M/S Cool Proport. Gain	-10.000 to -0.001	-0,9	-	RW	RW	MSL_CONF
756		ms_c_ti	M/S Cool Integral Time	10 to 120	30	s	RW	RW	MSL_CONF
757		ms_c_ts	M/S Cool Sampling Time	10 to 120	30	s	RW	RW	MSL_CONF
758		ms_pmp	Master/Slave Pump Type	0 to 3	2	-	RW	RW	MSL_CONF
761	02F9H	jbus_ena	JBus Control Enable	0 to 2	1	-	RW	RW	JBUSCONF
762	02FAH	jbus_add	JBus Slave Address	1 to 255	11	-	RW	RW	JBUSCONF
764	02FCH	jbus_frm	JBus Frame Type	0 to 5	0	-	RW	RW	JBUSCONF
766	02FEH	jbus_tmt	JBus Comm. Timeout	0 to 600	600	s	RW	RW	JBUSCONF
767	-	mbusoff1	Modbus Display offset	0 to 61440	16384		RW	RW	JBUSCONF
768	-	mbusoff2	Modbus Setpoint offset	0 to 61440	32768		RW	RW	JBUSCONF
769	-	mbusoff3	Modbus Config. offset	0 to 61440	28672		RW	RW	JBUSCONF
770	-	mbusoff4	Modbus Service offset	0 to 61440	36864		RW	RW	JBUSCONF
771				N.A.					
772				N.A.					
773				N.A.					
774				N.A.					
775				N.A.					
776				N.A.					

\* Corrected Inverter TO parameter [P039] enables to correct the value measured by TO sensor (located on the air heat exchanger). And OAT [P001] is equal to to2 [P039]

## 8 - START-UP CHECKLIST FOR 30RBV/RQV HEAT PUMPS (USE FOR JOB FILE)

### 8.1 - General information

General information	
Job name	
Location	
Installing contractor	
Distributor	
Start-up performed by	Date
Equipment	
Unit type	
Serial number	
Software version [P654]	
Compressor	Model number
	Serial number
Air handling equipment	Manufacturer
	Model number
	Serial number

### 8.2 - Available options and accessories

Options	Yes	No	Accessories	Yes	No
Italcoat coil protection			Master / Slave up to 4 units sensor		
Main switch			Domestic hot water management sensor		
Hydraulic module equipped with variable speed single pump low available pressure without expansion tank			Remote human interface		
Bacnet gateway			Additional outdoor ambient temperature sensor		
Lon gateway					
Hydraulic module without expansion tank					
Water filling system					
Expansion tank					
Local human interface					

### 8.3 - Checks before start of unit

	Yes	No	Comment
<b>CHECKS BEFORE START-UP</b>	Is there any shipping damage?		
	Unit is level in its installation		
	Power supply agrees with the unit name plate		
	Electrical circuit wiring has been sized and installed properly		
	Unit ground wire has been connected		
	Unit neutral wire has been connected		
	All terminals are tight		
	All cables and thermistors have been inspected for crossed wires		
	All plug assemblies are tight		
	All air handlers are operating		
	All water valves are open		
	All fluid piping is connected properly		
	All air has been vented from the system		
	Water pump is operating with the correct rotation		
	Water pump control has been properly interlocked with the heat pump		
Unit has been leak checked (including fittings): Locate, repair, and report any refrigerant leak			
All incoming power voltage is within rated voltage range			

## 8 - START-UP CHECKLIST FOR 30RBV/RQV HEAT PUMPS (USE FOR JOB FILE)

### 8.4 - Checks during operation of unit

Date / Hour							
<b>CHECKS DURING OPERATION</b>	Air	Outdoor Air Temp	P001	°C			
	Water	Entering Water Temp	P003	°C			
		Leaving Water Temp	P004	°C			
		Water Control Temp	P052	°C			
	Suction	Saturated Suction Temp	P008	°C			
		Suction Temperature	P009	°C			
		Superheat Temperature	P015	K			
		Superheat Target Temp	P016	K			
	Discharge	Discharge Temperature	P010	°C			
		Refrigerant Temperature	P005	°C			
	Compressor	Requested Compressor Frequency	P022	Hz			
		Actual Compressor Frequency	P023	Hz			
	Water control	Water Control Point	P051	°C			
		Flow Switch Status	P105	-			
		Safety Switch Status	P104	-			
	Water pressure / flow rate	Entering water heat exchanger pressure	-	kPa			
		Leaving water heat exchanger pressure	-	kPa			
		Pressure drop (without internal pump)	-	kPa			
		Flow rate from curves (without internal pump)	-	l/s			
		Or available external pressure (with internal pump)	-	kPa			
Power	Flow rate from curves (with internal pump)	-	l/s				
	Network Voltage	-	V				
	Input Amperage	-	A				

### 8.5 - Maintenance checks

Date / Hour							
<b>MAINTENANCE CHECKS</b>	Control	Mechanical check					
		Leakage check					
		HP switch test					
		Relief valve check					
		Electrical connection check					
	Freeze protection	Water freeze protection check					
		Add glycol in water (%)					
	Cleaning	Coil cleaning					
		Water filter cleaning					

Comments:



Order No.: 10096, 01.2018. Supersedes order No.: 02.2018.

Manufacturer reserves the right to change any product specifications without notice.



CARRIER participates in the ECP programme for LCPHP  
Check ongoing validity of certificate  
www.eurovent-certification.com  
www.certiflash.com



Quality and Environment  
Management Systems  
Approval

Manufactured by: Carrier SCS, Montluel, France.

Printed in the European Union.